

BUSINESS AFFAIRS AND HUMAN RESOURCES
APRIL 17-18, 2024

TAB	DESCRIPTION	ACTION
1	FY 2023 FINANCIAL STATEMENT AUDITS	Action Item
2	UNIVERSITY OF IDAHO Utility Public/Private Partnership – Amended and Restated Concession Agreement	Action Item
3	UNIVERSITY OF IDAHO Updated 6-Year Capital Project Plan	Action Item
4	UNIVERSITY OF IDAHO Design and Construction - Addition to the Huckabay WWAMI Medical Education Building	Action Item

BUSINESS AFFAIRS AND HUMAN RESOURCES
APRIL 17-18, 2024

SUBJECT

College/University FY2023 audit findings reported by the Idaho State Board of Education's external auditor

APPLICABLE STATUTE, RULE OR POLICY

Idaho State Board of Education Governing Policies & Procedures, Section V.H.4.f.

BACKGROUND/DISCUSSION

The Idaho State Board of Education (Board) is in contract with CliftonLarsonAllen LLP, an independent certified public accounting firm, to conduct the annual financial audits of Boise State University, Idaho State University, the University of Idaho, and Lewis-Clark State College.

The financial audits for FY2023 were conducted in accordance with Generally Accepted Government Auditing Standards and include an auditor's opinion on the basic financial statements prepared by each of the four institutions.

IMPACT

There were no material weaknesses or significant deficiencies for any of the four institutions for the financial statements, however there were material weaknesses and significant deficiencies found in the federal awards, mostly pertaining to student financial aid. Boise State University, Idaho State University, University of Idaho, and Lewis-Clark State College all received unmodified opinions from CLA that their respective financial statements present a true and fair reflection on their financial statements and compliance for major federal programs.

ATTACHMENTS

- Attachment 1 - CliftonLarsonAllen Audit Results Report
- Attachment 2 - Boise State University Schedule of Findings/Questioned Costs
- Attachment 3 - Idaho State University Schedule of Findings/Questioned Costs
- Attachment 4 - University of Idaho Schedule of Findings/Questioned Costs
- Attachment 5 - Lewis-Clark State College Schedule of Findings/Questioned Costs

STAFF COMMENTS AND RECOMMENDATIONS

On November 7, 2023, CliftonLarsonAllen (CLA) staff reviewed their audit findings with members of the Audit, Risk and Compliance Committee and Board staff. This was followed by presentations by senior managers from the college and universities on their financial statements.

The University of Idaho Foundation (a component unit reported in the University of Idaho's financial statements) continues to stay with Governmental Accounting Standards Board (GASB) presentation for their financial statements when CLA believes the Foundation should follow Financial Accounting Standards Board (FASB) presentation. CLA will continue to monitor this item for materiality.

CLA indicated that each College and University was cooperative and helpful.

BUSINESS AFFAIRS AND HUMAN RESOURCES
APRIL 17-18, 2024

On March 29, 2024, CLA reviewed the single audit findings with members of the Audit, Risk and Compliance Committee and Board staff.

BOARD ACTION

I move to accept from the Audit Committee the FY2023 financial audit reports for Boise State University, Idaho State University, University of Idaho, and Lewis-Clark State College, as submitted by CliftonLarsonAllen LLP in Attachment 1.

Moved by _____ Seconded by _____ Carried Yes _____ No _____



© 2021 CliftonLarsonAllen LLP

Idaho Office of State Board of Education

Fiscal Year 2023

Financial Statements and Single Audits Results

WEALTH ADVISORY | OUTSOURCING | AUDIT, TAX, AND CONSULTING

Investment advisory services are offered through CliftonLarsonAllen Wealth Advisors, LLC, an SEC-registered investment advisor

Agenda

 Introductions

 Scope of Engagements

 Responsibilities under GAAS

 Unique Items

 Results of Financial Statement Audit

 Required communications

 Results of Single Audit

 Questions



Idaho OSBE

Boise State University

- Jean Bushong
- Dominic Fabrizio

Idaho State University

- Chris Suda
- Tim Richter

University of Idaho

- Caroline Wright/Jean Bushong
- Sarah Tiau

Lewis-Clark State College

- Caroline Wright
- Sarah Tiau



Scope of Engagements



**Financial Statement
Audits**



Single Audits



**NCAA Agreed Upon
Procedures**

BSU
ISU
UI



**BSU Public Radio Audit
and CPB Filing**



Status of Each Engagement

Financial Statement Audit

- All 4 institutions reports have been issued

Single Audit

- BSU – in final review
- ISU – 6 programs. Testing ongoing.
- UI issued
- LCSC issued

NCAA Agreed Upon Procedures

- Fieldwork has begun

BSU Public Radio

- Fieldwork has begun



Responsibilities under US Generally Accepted Auditing Standards (GAAS)



Opinion: Financial statements in conformity with U.S. GAAP in all material respects.



Reasonable assurance free from material misstatement; not absolute



Risk-based audit: What is the risk of material error due to error, fraud, or noncompliance?

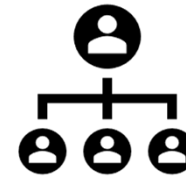

Our audit does not relieve management of its responsibilities.



Opinion is not over internal controls; opinion is over financial statements

Customized. Risk-based. Performed by Industry Professionals.



Create Opportunities

6

We'll Get You There

GASB Statement No. 94, Public-Private and Public-Public Partnerships and Availability Payment Arrangements

Unique Audit Issues

GASB Statement 96, Subscription-Based Information Technology Arrangements



Financial Statement Audit Results

Independent Auditors' Report

- Opinion – Unmodified
- Auditors' Responsibility
- Management's Responsibility
- Required Supplementary Information and Other Information
- Government Auditing Standards Report



Financial Statement Results (continued)

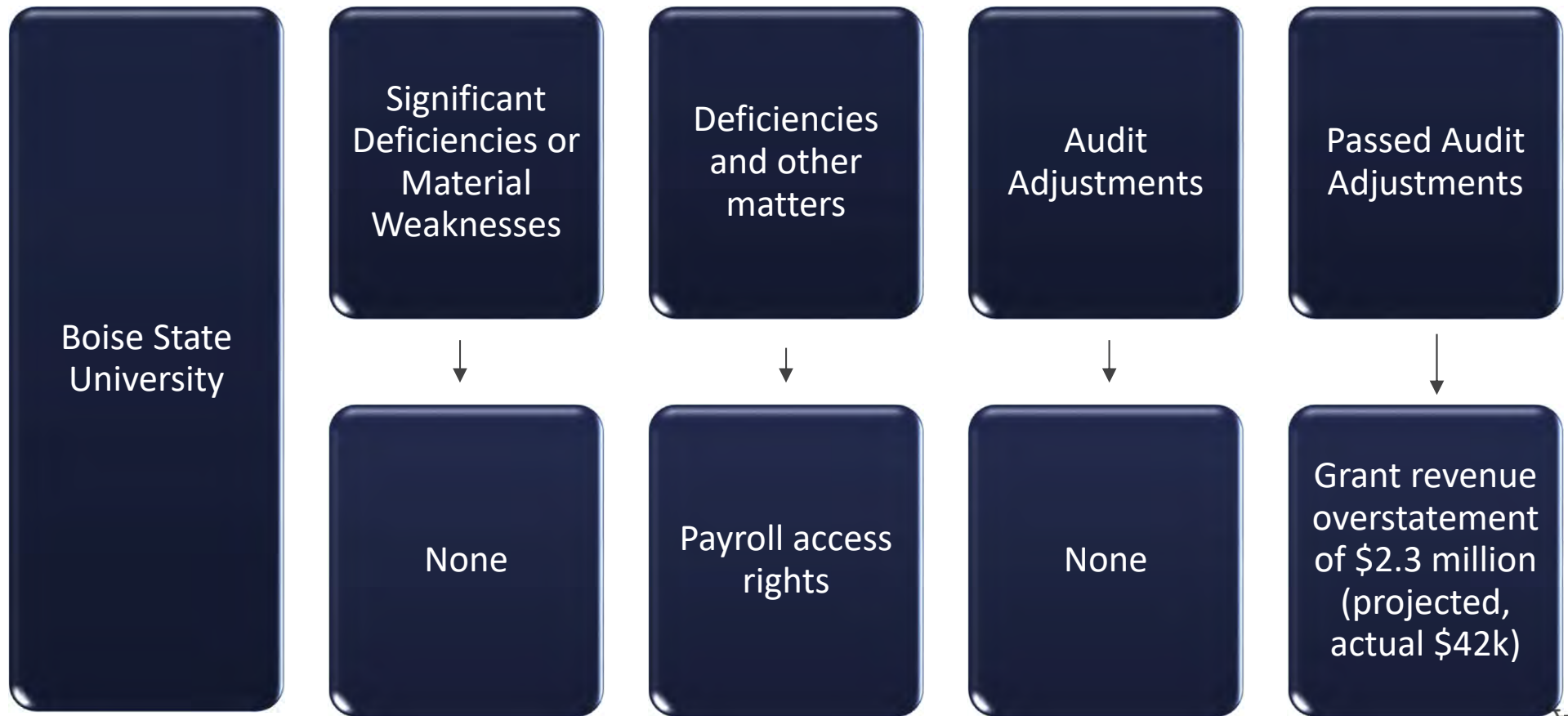

©2021 CliftonLarsonAllen LLP



Financial Statement Results (continued)

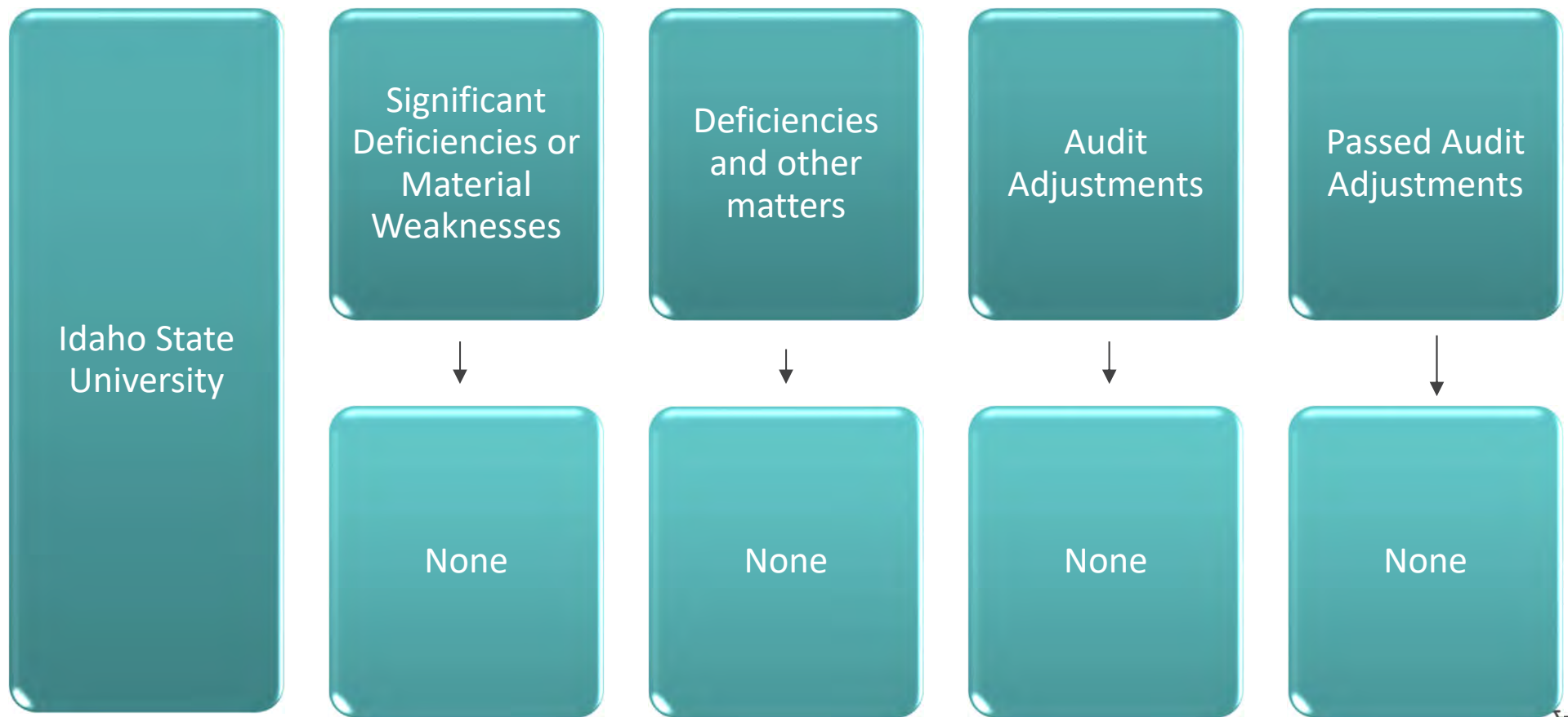

©2021 CliftonLarsonAllen LLP



Financial Statement Results (continued)

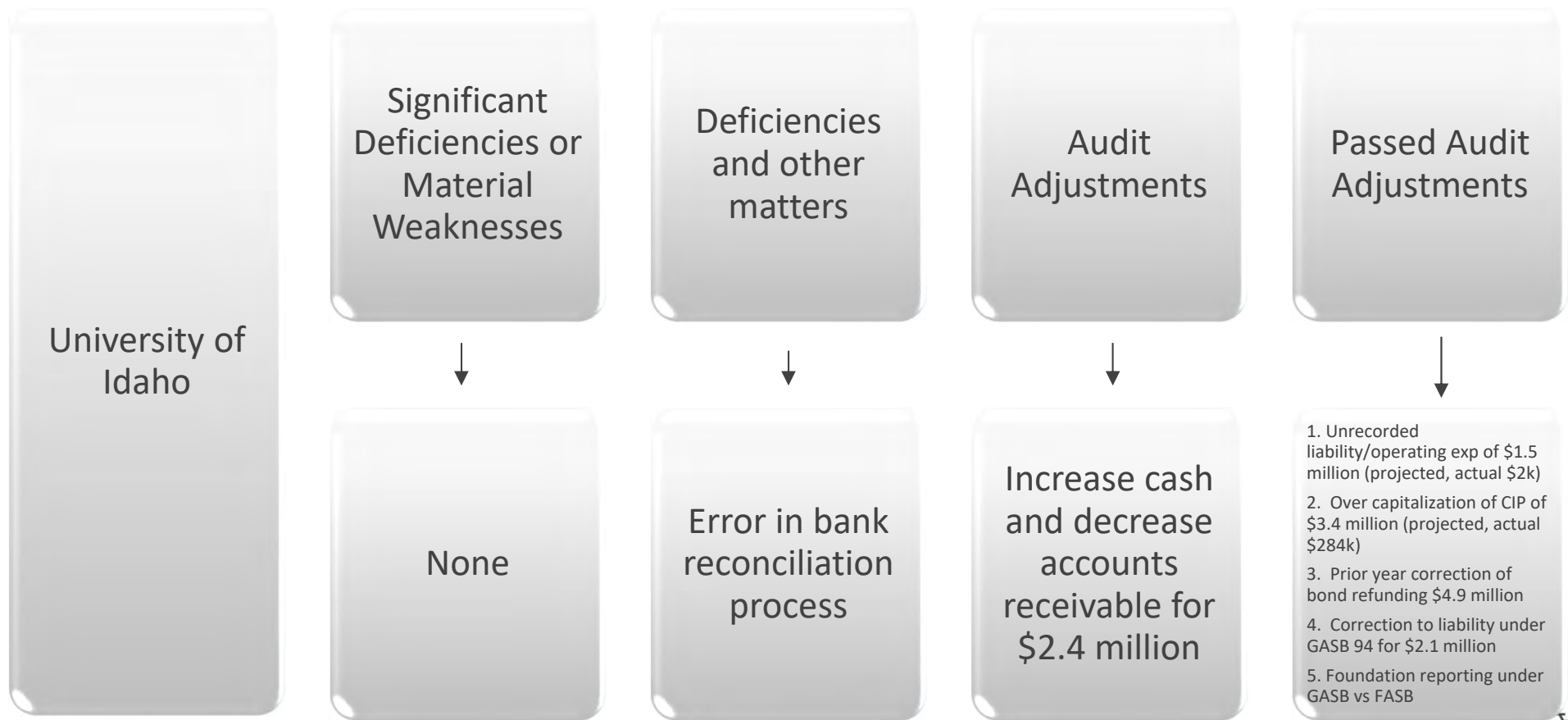

Financial Statement Results (continued)

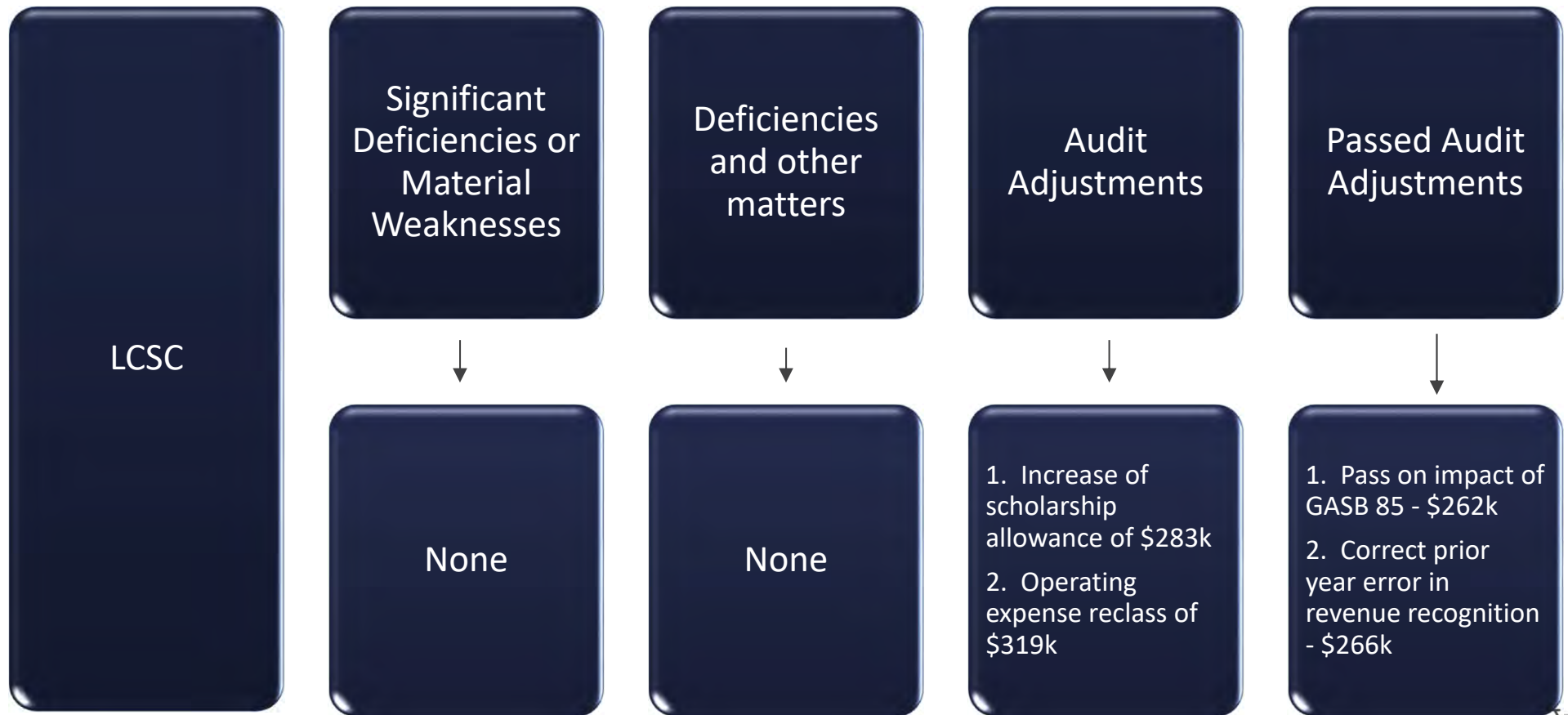

©2021 CliftonLarsonAllen LLP



Required Communications



Qualitative Aspects of Accounting Practices

New policy: GASB Statement No. 96 and 94
Accounting Estimates
Financial Disclosures



Difficulties Encountered in Performing the Audit – None



Uncorrected Misstatements:

See slides above



Corrected Misstatements:

See slides above



Required Communications

	Disagreements with Management	None
	Management Representations	
	Management Consultations with other Independent Accountants	None
	Significant Issues Discussed with Management Prior to Engagement	None
	Other Audit Findings or Issues	None



Single Audit Update

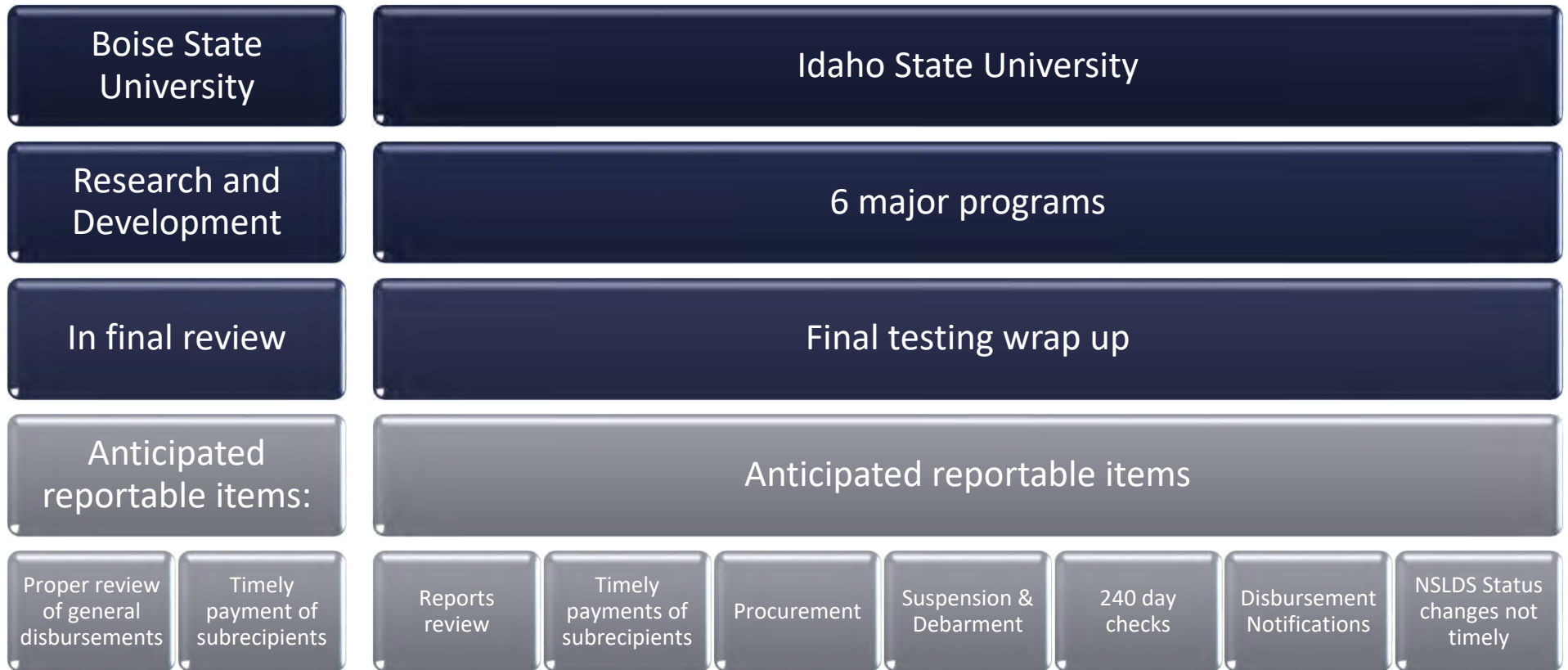

**Pending completion of review*



Single Audit Update (continued)

University of Idaho

Lewis-Clark State College

Student Financial Aid

Student Financial Aid

Report issued

Report issued

Reportable items:

Reportable items

240 day checks

NSLDS Reporting

Under –awarded direct loan

SEOG awarding

Lack of review of professional judgement

NSLDS Reporting

Perkins loan retention

©2021 CliftonLarsonAllen LLP



THANK YOU!

Management and staff were very cooperative and helpful.



Questions?



Jean Bushong, CPA
Principal
303-265-7884
Jean.Bushong@CLAconnect.com



CLAconnect.com



WEALTH ADVISORY | OUTSOURCING | AUDIT, TAX, AND CONSULTING

Investment advisory services are offered through CliftonLarsonAllen Wealth Advisors, LLC, an SEC-registered investment advisor

**BOISE STATE UNIVERSITY
SCHEDULE OF FINDINGS AND QUESTIONED COSTS
FOR THE YEAR ENDED JUNE 30, 2023**

Section I – Summary of Auditors’ Results

Financial Statements

- 1. Type of auditors’ report issued: Unmodified
- 2. Internal control over financial reporting:
 - Material weakness(es) identified? _____ yes x no
 - Significant deficiency(ies) identified? _____ yes x none reported
- 3. Noncompliance material to financial statements noted? _____ yes x no

Federal Awards

- Internal control over major federal programs:
 - Material weakness(es) identified? _____ yes x no
 - Significant deficiency(ies) identified? x yes _____ none reported
- Type of auditors’ report issued on compliance for major federal programs: Unmodified
- Any audit findings disclosed that are required to be reported in accordance with 2 CFR 200.516(a)? x yes _____ no

Identification of Major Federal Programs

Assistance Listing Number(s)	Name of Federal Program or Cluster
Various	Research and Development Cluster

- Dollar threshold used to distinguish between Type A and Type B programs: \$3,000,000
- Auditee qualified as low-risk auditee? x yes _____ no

**BOISE STATE UNIVERSITY
SUMMARY SCHEDULE OF PRIOR YEAR FINDINGS
FOR THE YEAR ENDED JUNE 30, 2023**

Section II – Financial Statement Findings

Our audit did not disclose any matters required to be reported in accordance with *Government Auditing Standards*.

Section III – Findings and Questioned Costs – Major Federal Programs

2023 – 001 – Cash Management

Federal Agency: U.S. Federal Government

Federal Program Title: Research and Development Cluster

Assistance Listing Number: Various

Federal Award Identification Number and Year: Multiple

Award Period: July 1, 2022 to June 30, 2023

Type of Finding:

- Other Matters
- Significant Deficiency in Internal Control over Compliance

Criteria or specific requirement: The Federal Government requires that when the reimbursement method is used, the Federal awarding agency or pass-through entity must make payment within 30 calendar days after receipt of the billing, unless the Federal awarding agency or pass-through entity reasonably believes the request to be improper (2 CFR section 200.305(b)(3)). Per Uniform Guidance 2 CFR 200.303, nonfederal entities receiving federal awards are required to establish and maintain internal controls designed to reasonably ensure compliance with federal laws, regulations, and program compliance requirements.

Condition: The University did not make payment to Subrecipients within the required 30 calendar days after receipt of the billing.

**BOISE STATE UNIVERSITY
SUMMARY SCHEDULE OF PRIOR YEAR FINDINGS
FOR THE YEAR ENDED JUNE 30, 2023**

Section III – Findings and Questioned Costs – Major Federal Programs (Continued)

Context: Nine exceptions were identified in a sample of forty subrecipient draw requests. Of the nine exceptions noted, exceptions ranged from 31 days to 90 days.

Questioned costs: None.

Cause: There was a misunderstanding of processes from backup staff. Additionally, there were delays in the department resulting in invoices not being processed timely. Lastly, approvals from the respective Principal Investigators were not being routed correctly.

Effect: Subrecipients did not receive their reimbursement timely and in accordance with federal regulations.

Repeat finding: No

Recommendation: We recommend the University evaluate its procedures and implement an additional control to review and approve the subrecipient reimbursements timely.

Views of responsible officials: Management agrees with the finding and has developed a plan to correct the finding.

2023 – 002 – Allowable Costs/Cost Principles

Federal Agency: U.S. Federal Government

Federal Program Title: Research and Development Cluster

Assistance Listing Number: Various

Federal Award Identification Number and Year: Multiple

Award Period: July 1, 2022 to June 30, 2023

Type of Finding:

- Other Matters
- Significant Deficiency in Internal Control over Compliance

Criteria or specific requirement: Entities receiving federal awards must identify in its accounts all federal awards expended and report those amounts on the Schedule of Expenditures of Federal Awards for the period the federal award was expended. Specifically, in accordance with Uniform Administrative Requirements outlined in 2 CFR 200, the guidance states:

- Per 2 CFR 200.502, The determination of when a Federal award is expended must be based on when the activity related to the Federal award occurs.

**BOISE STATE UNIVERSITY
SUMMARY SCHEDULE OF PRIOR YEAR FINDINGS
FOR THE YEAR ENDED JUNE 30, 2023**

- Per 2 CFR 200.303, entities must establish and maintain internal controls which provide reasonable assurance that federal award expenditures are in compliance with Federal statutes, regulations, and the terms and conditions of the Federal award.
- In addition, per 2 CFR 200.510, the Schedule of Expenditures of Federal Awards (SEFA) must be prepared to reflect the awards for the period covered by the auditee's financial statements.

Section III – Findings and Questioned Costs – Major Federal Programs (Continued)

- Lastly, section 2 CFR 200.510 states that for costs to be allowable, they should be determined in accordance with generally accepted accounting principles (with exceptions provided in that part).

Condition: The University's year-end cutoff controls allowed for certain costs from Fiscal Year 2022 to not be reported in the Fiscal Year 2022 SEFA but rather reported in the Fiscal Year 2023 SEFA.

Context: During our testing of 40 payroll transactions, we found one instance of 2022 fringe benefits being charged to a federal program in 2023. In addition, during our testing of 40 general disbursements transactions, we identified four instances of 2022 costs being charged to federal programs in 2023.

Questioned costs: Known amounts of 2022 costs included in the 2023 SEFA was \$3,214. (ALNs: 47.041, 47.083, 93.866, and 10.310 Award Numbers: 1663642, 1757324, R01AG059923, and 2022-67020-36410)

Cause: Per the University, the cause for the five exceptions were due to:

- The one payroll exception was due to the 2021-2022 Human Capital Management (HCM) implementation and the issues that implementation brought about. As disclosed in a direct communication with the University's cognizant agency, the initial custom software used for the allocation of fringe benefit costs did not work appropriately. As a result, throughout 2022, the University dedicated significant resources to address the HCM shortcomings. Then, in 2023, various corrections were made (again, as disclosed to the cognizant agency.) This sample was one of those costs that was identified as not properly being allocated to the federal program in the prior year; thus, was charged to the federal government in the current fiscal year.
- Three of the four general disbursement exceptions related to the University's procurement card accrual policy. Currently, the University's accrues for procurement card purchases through June 23, which leaves seven days of activity that flows into the next fiscal year. Three of our samples relate to procurement card charges incurred during these seven days.
- The last of the four general disbursements that related to a prior year but reported in the Fiscal Year 2023 was due to a staffing issue. A key employee responsible for monitoring specific departmental charges fell ill and was out for a period of time. Upon the employee's return, the employee spent time analyzing charges and identified the cost that should have been recorded as a federal charge in the prior year; thus, then charged the federal agency in Fiscal Year 2023.

Effect: The University was out of compliance as it relates to identifying and reporting federal costs in the period incurred.

Repeat finding: No

**BOISE STATE UNIVERSITY
SUMMARY SCHEDULE OF PRIOR YEAR FINDINGS
FOR THE YEAR ENDED JUNE 30, 2023**

Recommendation: We recommend the University evaluate its cutoff procedures to ensure federal costs are identified and reported in the correct fiscal year.

Views of responsible officials: Management agrees with the finding and has developed a plan to correct the finding.

BOISE STATE UNIVERSITY
SUMMARY SCHEDULE OF PRIOR YEAR FINDINGS (CONTINUED)
FOR THE YEAR ENDED JUNE 30, 2023

Section IV – Prior Year Findings

FINDINGS— FEDERAL AWARD PROGRAMS AUDITS

2022 – 001 R2T4

Condition: The University calculated R2T4 for modular students that had completed more than 49% of the days in the payment period. In addition, the University calculated one student's return using the incorrect completed percentage.

Status: Corrected.

IDAHO STATE UNIVERSITY
 SCHEDULE OF FINDINGS AND QUESTIONED COSTS
 FOR THE YEAR ENDED JUNE 30, 2023

Section I – Summary of Auditors’ Results

Financial Statements

1. Type of auditors’ report issued: Unmodified
2. Internal control over financial reporting:
 - Material weakness(es) identified? _____ yes x no
 - Significant deficiency(ies) identified? _____ yes x none reported
3. Noncompliance material to financial statements noted? _____ yes x no

Federal Awards

1. Internal control over major federal programs:
 - Material weakness(es) identified? x yes _____ no
 - Significant deficiency(ies) identified? x yes _____ none reported
2. Type of auditors’ report issued on compliance for major federal programs: Unmodified
3. Any audit findings disclosed that are required to be reported in accordance with 2 CFR 200.516(a)? x yes _____ no

Identification of Major Federal Programs

Assistance Listing Number(s)	Name of Federal Program or Cluster
Various	Student Financial Assistance Cluster
93.884	Primary Care Training and Enhancement
Various	Research and Development Cluster
84.042, 84.044, 84.047, 84.066, 84.217	TRIO Cluster
11.300	Economic Development Cluster
94.006	AmeriCorps
93.434	Every Student Succeeds Act/Preschool Development Grants

Dollar threshold used to distinguish between Type A and Type B programs:

\$808,704

Auditee qualified as low-risk auditee?

 X yes _____ no

IDAHO STATE UNIVERSITY
SCHEDULE OF FINDINGS AND QUESTIONED COSTS
FOR THE YEAR ENDED JUNE 30, 2023

Section II – Financial Statement Findings

Our audit did not disclose any matters required to be reported in accordance with *Government Auditing Standards*.

**IDAHO STATE UNIVERSITY
SCHEDULE OF FINDINGS AND QUESTIONED COSTS
FOR THE YEAR ENDED JUNE 30, 2023**

Section III – Findings and Questioned Costs – Major Federal Programs

2023-001: Reporting

Federal agency: Department of Health and Human Services

Federal program title: Primary Care Training and Enhancement & Every Student Succeeds Act/Preschool Development Grants

Assistance Listing Number: 93.884 & 93.434

Federal Award Identification Number and Year: Multiple

Award Period: July 1, 2022 to June 30, 2023

Type of Finding:

- Significant Deficiency in Internal Control over Compliance

Criteria or specific requirement: Uniform Grant Guidance (2 CFR 200.303) requires nonfederal entities receiving Federal awards establish and maintain internal controls designed to reasonably ensure compliance with Federal laws, regulations, and program compliance requirements. Effective internal controls should include procedures to ensure reports are formally reviewed by someone who did not prepare the report to verify the correct information and data is submitted.

Condition & Context: The University did not have a documented or formal review and approval process in place for reports prior to submission.

Questioned costs: None.

Cause: Supervisory review and approval is currently undocumented and is only communicated verbally.

Effect: Failure to properly review Reports could result in an improper information and data being submitted.

Repeat Finding: No.

Recommendation: ISU should implement formal review procedures to document review and approvals over required reports.

Views of responsible officials: Management agrees with this finding.

**IDAHO STATE UNIVERSITY
SCHEDULE OF FINDINGS AND QUESTIONED COSTS
FOR THE YEAR ENDED JUNE 30, 2023**

2023-002: Cash Management-Subrecipient

Federal Agency: U.S. Federal Government

Federal Program Title: Research and Development Cluster

Assistance Listing Number: 93.859

Federal Award Identification Number and Year: 1R01GM137083 - 2023

Award Period: July 1, 2022 to June 30, 2023

Type of Finding:

- Other Matters
- Significant Deficiency in Internal Control over Compliance

Criteria or specific requirement: The Federal Government requires that when the reimbursement method is used, the Federal awarding agency or pass-through entity must make payment within 30 calendar days after receipt of the billing, unless the Federal awarding agency or pass-through entity reasonably believes the request to be improper (2 CFR section 200.305(b)(4)). In addition, per the Uniform Guidance 2 CFR 200.303, nonfederal entities receiving federal awards are required to establish and maintain internal controls designed to reasonably ensure compliance with federal laws, regulations, and program compliance requirements.

Condition: The University did not make payment to Subrecipients within the required 30 calendar days after receipt of the billing.

Context: One subrecipient invoice, totaling \$1,601, out of 8 tested, totaling \$43,340, was not paid within the required 30 days.

Questioned costs: None.

Cause: The invoice was sent to the wrong email for approval.

Effect: Subrecipients did not receive their reimbursement timely.

Repeat finding: No

Recommendation: We recommend the University evaluate its procedures and implement an additional control to review and approve the Subrecipient reimbursements timely.

Views of responsible officials: Management agrees with the finding and has developed a plan to correct the finding.

**IDAHO STATE UNIVERSITY
SCHEDULE OF FINDINGS AND QUESTIONED COSTS
FOR THE YEAR ENDED JUNE 30, 2023**

2023-003: Procurement

Federal Agency: U.S. Federal Government

Federal Program Title: Research and Development Cluster

Assistance Listing Number: Various

Federal Award Identification Number and Year: Multiple

Award Period: July 1, 2022 to June 30, 2023

Type of Finding:

- Other Matters
- Significant Deficiency in Internal Control over Compliance

Criteria or specific requirement: The Federal Government requires that all procurement transactions for the acquisition of property or services required under a Federal award must be conducted in a manner providing full and open competition consistent with the standards of 2 CFR section 200.319 and 2 CFR section 200.320. In addition, per the Uniform Guidance CFR 200.303, nonfederal entities receiving federal awards are required to establish and maintain internal controls designed to reasonably ensure compliance with federal laws, regulations, and program compliance requirements.

Condition: The University did not have documentation for reasonings of why they did not obtain competitive bids.

Context: During our testing we identified 2 of the 8 contracts tested did not include adequate documentation to award the contracts without a competitive bid process.

Questioned costs: \$27,287

Cause: A misunderstanding of the procurement process by grant personnel.

Effect: Documentation for why the University did not obtain competitive bids was undocumented.

Repeat finding: No

Recommendation: We recommend the University evaluate its procedures and implement an additional control to document reasons for obtaining competitive bids.

Views of responsible officials: Management agrees with the finding and has developed a plan to correct the finding.

**IDAHO STATE UNIVERSITY
SCHEDULE OF FINDINGS AND QUESTIONED COSTS
FOR THE YEAR ENDED JUNE 30, 2023**

2023-004: Suspension Debarment

Federal Agency: U.S. Federal Government

Federal Program Title: Research and Development Cluster

Assistance Listing Number: Various

Federal Award Identification Number and Year: Multiple

Award Period: July 1, 2022 to June 30, 2023

Type of Finding:

- Other Matters
- Significant Deficiency in Internal Control over Compliance

Criteria or specific requirement: The Federal Government requires that when a non-federal entity enters into a covered transaction with an entity at a lower tier, the non-federal entity must verify that the entity, as defined in 2 CFR section 180.995 and agency adopting regulations, is not suspended or debarred or otherwise excluded from participating in the transaction. In addition, per the Uniform Guidance 2 CFR 200.303, nonfederal entities receiving federal awards are required to establish and maintain internal controls designed to reasonably ensure compliance with federal laws, regulations, and program compliance requirements.

Condition: The University was not able to provide a verification check occurring before entering into contract with a vendor/subrecipient.

Context: During our testing of 5 contracts out of a population of 14 vendors/subrecipients, we identified one vendor/subrecipient that the University could not provide a verification check prior to entering the contract.

Questioned costs: None.

Cause: Verification check did not occur before entering into contract with vendor/subrecipient.

Effect: The University entered into contract with a vendor/subrecipient prior to performing a verification check.

Repeat finding: No

Recommendation: We recommend the University evaluate its procedures and implement an additional control to ensure verification checks are occurring prior to entering into contract with a vendor/subrecipient.

Views of responsible officials: Management agrees with the finding and has developed a plan to correct the finding.

**IDAHO STATE UNIVERSITY
SCHEDULE OF FINDINGS AND QUESTIONED COSTS
FOR THE YEAR ENDED JUNE 30, 2023**

2023-005: Special Tests & Provisions

Federal Agency: Department of Education

Federal Program Title: Student Financial Assistance Cluster

Assistance Listing Number: Various

Federal Award Identification Number and Year: Multiple

Award Period: July 1, 2022 to June 30, 2023

Type of Finding:

- Other Matters
- Significant Deficiency in Internal Control over Compliance

Criteria or specific requirement: The Department of Education, 2 CFR part 200 section 200.303, requires that non-Federal entities receiving Federal awards (i.e., auditee management) establish and maintain internal control designed to reasonably ensure compliance with Federal statutes, regulations, and the terms and conditions of the Federal award. The Code of Federal Regulations, 34 CFR 688.164, requires any Title IV federal funds disbursed to a student or parent that are not received or negotiated must be returned to the appropriated federal financial aid program no later than 240 days after the check or electronic fund transfer (EFT) was issued. If a check or an EFT is returned, the University may make additional attempts to deliver the funds, provided that those attempts are made no later than 45 days after the funds were returned or rejected. In case where the University does not make another attempt, the funds must be returned before the end of the initial 45-day period. The University must cease all attempts to disburse the funds and return them no later than 240 days after the date it issued the first check. Under no circumstances may unclaimed Title IV FSA funds escheat to the state, or revert to the University, or any other third party.

Condition: The University was not in compliance with the federal financial aid regulations requirement that any Title IV federal funds disbursed to a student or parent that are not received or negotiated must be returned to the appropriated federal financial aid program no later than 240 days after the check or electronic fund transfer (EFT) was issued.

Context: During the testing of the outstanding Title IV student check listing totaling 76 outstanding checks, we identified eight instances of stale checks that were aged greater than 240 days.

Questioned costs: \$14,949.02

Cause: The University did not have a process in place to monitor the checks throughout the year.

Effect: The University is not in compliance with Department of Education requirements.

Repeat finding: No

Recommendation: We recommend that the University review the requirement and implement a monitoring control to monitor the checks throughout the year. In addition, for the checks outstanding greater than 240 days, the University should return the funding to the U.S. Department of Education.

Views of responsible officials: Management agrees with the finding and has developed a plan to correct the finding.

**IDAHO STATE UNIVERSITY
SCHEDULE OF FINDINGS AND QUESTIONED COSTS
FOR THE YEAR ENDED JUNE 30, 2023**

2023-006: Eligibility

Federal Agency: Department of Education

Federal Program Title: Student Financial Assistance Cluster

Assistance Listing Number: Various

Federal Award Identification Number and Year: Multiple

Award Period: July 1, 2022 to June 30, 2023

Type of Finding:

- Other Matters
- Material Weakness

Criteria or specific requirement: The Department of Education requires the institution must notify the student, or parent, in writing of (1) the date and amount of the disbursement; (2) the student's right, or parent's right, to cancel all or a portion of that loan or loan disbursement and have the loan proceeds returned to the holder of that loan or the TEACH Grant payments returned to ED; and (3) the procedure and time by which the student or parent must notify the institution that he or she wishes to cancel the loan, TEACH Grant, or TEACH Grant disbursement. The notification requirement for loan funds applies only if the funds are disbursed by EFT payment or master check (34 CFR 668.165). In addition, per the Uniform Guidance 2 CFR 200.303, nonfederal entities receiving federal awards are required to establish and maintain internal controls designed to reasonably ensure compliance with federal laws, regulations, and program compliance requirements.

Condition: The University did not properly notify students when loans were disbursed and credited to student's accounts.

Context: During our Eligibility testing of 40 students, we identified that there were 29 students that received loan disbursements however, all 29 students did not receive the required notification for each loan disbursement.

Questioned costs: None

Cause: The college did not send loan disbursement notifications, notifications were only provided when aid amounts changed from their initial award letter.

Effect: Tailored award disbursement notifications inform the student or parent of the right to cancel all or a portion of that loan or loan disbursements and have the loan proceeds returned to the holder of that loan. The notifications also outline the procedure and time by which the student or parent must notify the institution that he or she wishes to cancel the loan.

Repeat finding: No

Recommendation: We recommend the University evaluate its procedures around disbursements of loans and ensure that notifications of disbursements are sent and contain all of the required elements outlined in the FSA handbook.

Views of responsible officials: Management agrees with the finding and has developed a plan to correct the finding.

**IDAHO STATE UNIVERSITY
SCHEDULE OF FINDINGS AND QUESTIONED COSTS
FOR THE YEAR ENDED JUNE 30, 2023**

2023-007: Special Tests & Provisions

Federal Agency: Department of Education

Federal Program Title: Student Financial Assistance Cluster

Assistance Listing Number: Various

Federal Award Identification Number and Year: Multiple

Award Period: July 1, 2022 to June 30, 2023

Type of Finding:

- Other Matters
- Significant Deficiency in Internal Control over Compliance

Criteria or specific requirement: The Code of Federal Regulations, 34 CFR 682.610, states that institutions must report accurately the enrollment status of all students regardless of if they receive aid from the institution or not. Changes to said status are required to be reported within 30 days of becoming aware of the status change, or with the next scheduled transmission of statuses if the scheduled transmission is within 60 days. In addition per the Uniform Guidance 2 CFR 200.303, non-federal entities receiving federal awards are required to establish and maintain internal controls designed to reasonable ensure compliance with federal laws, regulations, and program compliance requirements.

Condition: The University did not properly report student enrollment changes for students who received federal student aid to the National Student Loan Data System (NSLDS).

Context: During our testing of 40 students, we identified one instance for which the student's enrollment status was not correctly reported to NSLDS, two instances where the enrollment effective date was not reported correctly to NSLDS and nine instances where the status changes were not reported timely to NSLDS.

Questioned costs: None

Cause: The University did not have proper procedures in place to verify students status in NSLDS matched the institutions records in a timely manner.

Effect: Failure to properly report enrollment status changes on NSLDS could affect the timing of the grace period for repayment of Title IV loans. Additionally, the College was not in compliance with the requirements to properly report student enrollment data correctly or timely to NSLDS.

Repeat finding: No

Recommendation: We recommend that the University implement procedures to ensure that enrollment data, changes in status and effective dates within NSLDS match the records of the institution and are reported timely. And we recommend that the College implement formal review procedures to document the review process.

Views of responsible officials: Management agrees with the finding and has developed a plan to correct the finding.

IDAHO STATE UNIVERSITY
SCHEDULE OF PRIOR YEAR FINDINGS
FOR THE YEAR ENDED JUNE 30, 2023

Section IV – Prior Year Findings

FINDINGS— FEDERAL AWARD PROGRAMS AUDITS

2022-001: Cash Management

Type of Finding:

- Significant Deficiency in Internal Control over Compliance

Condition: The University did not have a formal documented review process in place to ensure G5 drawdowns were reviewed prior to submitting the drawdown request.

Status: Corrected.

UNIVERSITY OF IDAHO
 SCHEDULE OF FINDINGS AND QUESTIONED COSTS
 YEAR ENDED JUNE 30, 2023

Section I – Summary of Auditors’ Results

Financial Statements

1. Type of auditors’ report issued: Unmodified
2. Internal control over financial reporting:
- Material weakness(es) identified? _____ yes x no
 - Significant deficiency(ies) identified? _____ yes x none
3. Noncompliance material to financial statements noted? _____ yes x no

Federal Awards

1. Internal control over major federal programs:
- Material weakness(es) identified? _____ yes x no
 - Significant deficiency(ies) identified? x yes _____ none
2. Type of auditors’ report issued on compliance for major federal programs: Unmodified
3. Any audit findings disclosed that are required to be reported in accordance with 2 CFR 200.516(a)? x yes _____ no

Identification of Major Federal Programs

84.007, 84.033, 84.038, 84.063, 84.268 Student Financial Assistance Cluster

Dollar threshold used to distinguish between Type A and Type B programs: \$3,000,000

Auditee qualified as low-risk auditee? x yes _____ no

**UNIVERSITY OF IDAHO
SCHEDULE OF FINDINGS AND QUESTIONED COSTS (CONTINUED)
YEAR ENDED JUNE 30, 2023**

Section II – Financial Statement Findings

Our audit did not disclose any matters required to be reported in accordance with *Government Auditing Standards*.

Section III – Findings and Questioned Costs – Major Federal Programs

2023-001

Federal Agency: U.S. Department of Education

Federal Program Name: Student Financial Assistance Cluster

Assistance Listing Number: 84.268 – Federal Direct Loans
84.063 – Federal Pell Grant Program
84.007 – Federal Supplemental Educational Opportunity Grants

Federal Award Identification Number and Year: 2022-2023 – P268K23010, P063P220101, P007A221093

Award Period: July 1, 2022 to June 30, 2023

Type of Finding: -Significant Deficiency in Internal Control Over Compliance
-Other Matters

Criteria or specific requirement: 2 CFR part 200 section 200.303 requires that non-Federal entities receiving Federal awards (i.e., auditee management) establish and maintain internal control designed to reasonably ensure compliance with Federal statutes, regulations, and the terms and conditions of the Federal award. The Code of Federal Regulations, 34 CFR 688.164, requires any Title IV federal funds disbursed to a student or parent that are not received or negotiated must be returned to the appropriated federal financial aid program no later than 240 days after the check or electronic fund transfer (EFT) was issued. If a check or an EFT is returned, the University may make additional attempts to deliver the funds, provided that those attempts are made no later than 45 days after the funds were returned or rejected. In case where the University does not make another attempt, the funds must be returned before the end of the initial 45-day period. The University must cease all attempts to disburse the funds and return them no later than 240 days after the date it issued the first check. Under no circumstances may unclaimed Title IV FSA funds escheat to the state, or revert to the University, or any other third party.

Condition: During our testing of the 240-day requirement, we noted the University was not in compliance with the federal financial aid regulations requirement that any Title IV federal funds disbursed to a student or parent that are not received or negotiated must be returned to the appropriated federal financial aid program no later than 240 days after the check or electronic fund transfer (EFT) was issued.

Questioned costs: 84.268 – Federal Direct loans – \$25,871
84,063 – Federal Pell Grant Programs – \$1,477
84.007 – Federal SEOG Grant Programs – \$14

**UNIVERSITY OF IDAHO
SCHEDULE OF FINDINGS AND QUESTIONED COSTS (CONTINUED)
YEAR ENDED JUNE 30, 2023**

Section III – Findings and Questioned Costs – Major Federal Programs (Continued)

2023-001 (Continued)

Context: During our testing, it was noted 68 out of 708 outstanding checks were Title IV federal funds checks that were over the 240-day limit.

Cause: The University did not have adequate processes in place to monitor outstanding Title IV disbursement checks throughout the year.

Effect: The University is not in compliance with Department of Education requirements.

Repeat finding: No

Recommendation: CLA recommends that the University review the requirement and implement a monitoring control to monitor the checks throughout the year. In addition, for the checks outstanding greater than 240 days, the University should return the funding to the U.S. Department of Education.

Views of Responsible Officials: There is no disagreement with the audit finding, and the university has implemented stronger controls over these processes.

2023-002

Federal Agency: U.S. Department of Education

Federal Program Name: Student Financial Assistance Cluster

Assistance Listing Number: 84.268 – Federal Direct Loans
 84.063 – Federal Pell Grant Program
 84.007 – Federal Supplemental Educational Opportunity Grants
 84.033 – Federal Work Study Program

Federal Award Identification Number and Year: 2022-2023 – P268K23010, P063P220101, P007A221093, P033A221093

Award Period: July 1, 2022 to June 30, 2023

Type of finding: -Significant Deficiency in Internal Control Over Compliance
 -Other Matters

Criteria or specific requirement: The Code of Federal Regulations, 34 CFR 682.610, states that institutions must report accurately the enrollment status of all students regardless of if they receive aid from the institution or not. This includes the enrollment effective date and related enrollment status, which must be reported for both the Campus-Level and the Program-Level, as well as the program begin date. Changes to said status are required to be reported within 30 days of becoming aware of the status change, or with the next scheduled transmission of statuses if the scheduled transmission is within 60 days. In addition, Uniform Grant Guidance (2 CFR 200.303) requires nonfederal entities receiving Federal awards establish and maintain internal controls designed to reasonably ensure compliance with Federal laws, regulations, and program compliance requirements.

**UNIVERSITY OF IDAHO
SCHEDULE OF FINDINGS AND QUESTIONED COSTS (CONTINUED)
YEAR ENDED JUNE 30, 2023**

Section III – Findings and Questioned Costs – Major Federal Programs (Continued)

2023-002 (Continued)

Condition: There were instances in which the University did not report the correct status and effective dates and status changes were not always reported timely.

Questioned costs: None

Context: In our statistically valid sample of sixty students selected for NSLDS enrollment reporting testing, we identified ten samples for which the student's change in enrollment status was not properly updated. Five samples for which the enrollment effective date was not reported correctly. The status change for three samples was not reported timely and those same three samples enrollment was not certified every 60 days.

Cause: University of Idaho did not have proper procedures in place to verify students' status in NSLDS matched the institutions records in a timely manner.

Effect: Failure to properly report enrollment status changes on NSLDS could affect the timing of the grace period for repayment of Title IV loans. Additionally, the University was not in compliance with the requirements to properly report student enrollment data correctly or timely to NSLDS.

Repeat finding: No.

Recommendation: We recommend that the University work with their third-party servicer and implement procedures to ensure that enrollment data, changes in status and effective dates within NSLDS are reported timely. And we recommend that the University implement formal review procedures to document the review process.

Views of responsible officials: There is no disagreement with the audit finding.

2023-003

Federal Agency: U.S. Department of Education

Federal Program Name: Student Financial Assistance Cluster

Assistance Listing Number: 84.268 – Federal Direct Loans

Federal Award Identification Number and Year: 2022-2023 P268K23010

Award Period: July 1, 2022 to June 30, 2023

Type of Finding: -Significant Deficiency in Internal Control Over Compliance
 -Other Matters

**UNIVERSITY OF IDAHO
SCHEDULE OF FINDINGS AND QUESTIONED COSTS (CONTINUED)
YEAR ENDED JUNE 30, 2023**

Section III – Findings and Questioned Costs – Major Federal Programs (Continued)

2023-003 (Continued)

Criteria or specific requirement: The amount of a student's federal direct loan award for an academic year is based on year in college and enrollment level. CFR 685.203 lays out the calculation for both federal direct subsidized loans and unsubsidized loans. In addition, Uniform Grant Guidance (2 CFR 200.303) requires nonfederal entities receiving Federal awards establish and maintain internal controls designed to reasonably ensure compliance with Federal laws, regulations, and program compliance requirements.

Condition: The University under awarded 1 student for Federal Direct Loans.

Questioned costs: None

Context: During our eligibility testing of forty students, one student was under awarded federal direct unsubsidized loans by \$2,000. Student had transfer credits that came in after loan awards were disbursed that resulted in a change in class standing. Student was eligible for \$2,000 in additional loans but was not notified of the additional amount available.

Cause: The University did not have proper procedures in place to identify when a student changes class standing in the middle of the term.

Effect: Student was under awarded Federal Direct Unsubsidized loans.

Repeat finding: No.

Recommendation: We recommend that the University refine its procedure for identifying when students change class standing in the middle of the term so students can then be notified of their change in class standing that resulted in an increase to their award package.

Views of responsible officials: There is no disagreement with the audit finding.

2023-004

Federal Agency: U.S. Department of Education

Federal Program Name: Student Financial Assistance Cluster

Assistance Listing Number: 84.007 – Federal Supplemental Educational Opportunity Grants

Federal Award Identification Number and Year: 2022-2023 – P007A221093

Award Period: July 1, 2022 to June 30, 2023

Type of Finding: -Significant Deficiency in Internal Control Over Compliance
 -Other matters

UNIVERSITY OF IDAHO
SCHEDULE OF FINDINGS AND QUESTIONED COSTS (CONTINUED)
YEAR ENDED JUNE 30, 2023

Section III – Findings and Questioned Costs – Major Federal Programs (Continued)

2023-004 (Continued)

Criteria or specific requirement: The Code of Federal Regulations, 34 CFR 676.10(a)(1) and (2) states “In selecting among eligible students for FSEOG awards in each award year, an institution shall select those students with the lowest expected family contributions who will also receive Federal Pell Grants in that year. If the institution has FSEOG funds remaining after giving FSEOG awards to all the Federal Pell Grant recipients at the institution, the institution shall award the remaining FSEOG funds to those eligible students with the lowest expected family contributions who will not receive Federal Pell Grants.” In addition, Uniform Grant Guidance (2 CFR 200.303) requires nonfederal entities receiving Federal awards establish and maintain internal controls designed to reasonably ensure compliance with Federal laws, regulations, and program compliance requirements.

Condition: The University awarded FSEOG to students with EFC’s higher than zero (the lowest expected family contribution) when there were students with the zero EFCs who did not receive FSEOG and were eligible to receive FSEOG.

Questioned Costs: \$8,422

Context: In our sample of 8 FSEOG recipients there were four that had an EFC higher than zero. Two of the four were within the University's policy to award eligible students with EFCs in the 0-3500 range who meet the priority deadline. The other two were above the 3500 EFC policy level that had requested funding due to special financial situations. In our eligibility sample of 40, we noted there were Pell recipients with a zero EFC and remaining need that were not awarded FSEOG funds.

Cause: The University's policy is to award FSEOG to PELL recipients who have met the FAFSA priority deadline and have an EFC below 3,500. The University policy for awarding FSEOG funds was not capturing all students who had the lowest EFC and remaining need.

Effect: The University is not in compliance with the FSEOG awarding guidelines.

Repeat finding: No

Recommendation:

We recommend that the University review their FSEOG awarding policy and procedures to ensure FSEOG is awarded to students with the lowest expected family contributions receive the funding.

Views of responsible officials: There is no disagreement with the audit finding.

**UNIVERSITY OF IDAHO
SCHEDULE OF FINDINGS AND QUESTIONED COSTS (CONTINUED)
YEAR ENDED JUNE 30, 2023**

Section III – Findings and Questioned Costs – Major Federal Programs (Continued)

2023-005

Federal agency: U.S. Department of Education

Federal Program Name: Student Financial Assistance Cluster

Assistance Listing Number: 84.268 – Federal Direct Loans
84.063 – Federal Pell Grant Program
84.007 – Federal Supplemental Educational Opportunity Grants
84.033 – Federal Work Study Program

Federal Award Identification Number and Year: 2022-2023 – P268K23010, P063P220101, P007A221093, P033A221093

Award Period: July 1, 2022 to June 30, 2023

Type of Finding: -Significant Deficiency in Internal Control Over Compliance

Criteria or specific requirement: Uniform Grant Guidance (2 CFR 200.303) requires nonfederal entities receiving Federal awards establish and maintain internal controls designed to reasonably ensure compliance with Federal laws, regulations, and program compliance requirements.

Condition: The University did not have observable controls to test over the professional judgement process. The University had an instance in which supervisory review of the verification procedure was not documented.

Questioned costs: None.

Context: During the testing of eligibility, we noted there were three instances in which professional judgement was used in the awarding process. We were unable to identify a specific control in place to ensure that any errors in professional judgement process would be prevented and detected in a timely manner. We did note that there is no formal review process over the professional judgement process. In addition, we noted in our verification testing that one out of twelve students tested did not have a signed statement of educational purpose by either the preparer or the reviewer.

Cause: There are no procedures to review professional judgement decisions made by the person performing the process. The review process for verification procedures was not being followed.

Effect: It is possible that errors could occur and not be caught in a timely manner.

Repeat finding: No

Recommendation: We recommend the University implement formal review procedures over the professional judgement process and to improve the process for review of verification documents so that it is not overlooked.

Views of responsible officials and planned corrective action: There is no disagreement with the audit finding.

LEWIS-CLARK STATE COLLEGE
 SCHEDULE OF FINDINGS AND QUESTIONED COSTS
 YEAR ENDED JUNE 30, 2023

Section I – Summary of Auditors’ Results

• **Financial Statements**

- 1. Type of auditors’ report issued: Unmodified
- 2. Internal control over financial reporting:
 - Material weakness(es) identified? _____ yes x no
 - Significant deficiency(ies) identified? _____ yes x none reported
- 3. Noncompliance material to financial statements noted? _____ yes x no

• **Federal Awards**

- 1. Internal control over major federal programs:
 - Material weakness(es) identified? x yes _____ no
 - Significant deficiency(ies) identified? x yes _____ none reported
- 2. Type of auditors’ report issued on compliance for major federal programs: Unmodified
- 3. Any audit findings disclosed that are required to be reported in accordance with 2 CFR 200.516(a)? x yes _____ no

Identification of Major Federal Programs

Assistance Listing Number(s)	Name of Federal Program or Cluster
84.007, 84.033, 84.038, 84.063, 84.268 84.379, 93.364	Student Financial Assistance Cluster

Dollar threshold used to distinguish between Type A and Type B programs: \$750,000/\$187,500

Auditee qualified as low-risk auditee? x yes _____ no

**LEWIS-CLARK STATE COLLEGE
SCHEDULE OF FINDINGS AND QUESTIONED COSTS
YEAR ENDED JUNE 30, 2023**

Section II – Financial Statement Findings

Our audit did not disclose any matters required to be reported in accordance with *Government Auditing Standards*.

LEWIS-CLARK STATE COLLEGE
SCHEDULE OF FINDINGS AND QUESTIONED COSTS
YEAR ENDED JUNE 30, 2023

Section III – Findings and Questioned Costs – Major Federal Programs

2023-001 Errors in Reporting for NSLDS

Federal Agency: Department of Education

Federal Program Name: Student Financial Assistance Cluster

Assistant Listing Number: 84.007/84.033/84.063/84.268/84.379/93.364

Federal Award Identification Number and Year: P268K230100 - 2023, P007A221087 - 2023, P063P220100 - 2023, P033A221087 - 2023, P379T230100 - 2023, E4C14916 - 2023

Award Period: July 1, 2022 to June 30, 2023

Type of Finding: Material Weakness in Internal Control over Compliance; Compliance, Material Noncompliance

Criteria or Specific Requirement: The Code of Federal Regulations, 34 CFR 682.610, states that institutions must report accurately the enrollment status of all students regardless of if they receive aid from the institution or not. Changes to said status are required to be reported within 30 days of becoming aware of the status change, or with the next scheduled transmission of statuses if the scheduled transmission is within 60 days.

Condition: The College did not correctly update student status changes and enrollment effective dates, nor did the College do so timely.

Questioned Costs: None

Context: In our statistically valid sample of sixty students selected for NSLDS enrollment reporting testing, we identified twenty eight samples for which the student's enrollment status was not correctly reported to NSLDS, thirty samples for which the enrollment effective date was not correctly reported to NSLDS, twenty eight samples for which the change in status was not reported timely to NSLDS, and twenty eight samples for which the enrollment was not certified within 60 days.

Cause: The College did not timely or properly report student status changes to NSLDS through their third-party servicer, National Student Clearinghouse (NSC).

Effect: Failure to properly report enrollment status changes on NSLDS could affect the timing of the grace period for repayment of Title IV loans. Additionally, the College was not in compliance with the requirements to properly report student enrollment data correctly or timely to NSLDS.

Repeat Finding: Yes, 2022-002

Recommendation: We recommend that the College work with their third-party servicer and implement procedures to ensure that enrollment data, changes in status and effective dates within NSLDS are reported timely.

Views of Responsible Officials and Planned Corrective Action: Management agrees with the finding and has developed a plan to correct it.

LEWIS-CLARK STATE COLLEGE
SCHEDULE OF FINDINGS AND QUESTIONED COSTS
YEAR ENDED JUNE 30, 2023

Section III – Findings and Questioned Costs – Major Federal Programs (Continued)

2023-002 Special Tests and Provisions – Perkins

Federal Agency: Department of Education

Federal Program Name: Student Financial Assistance Cluster

Assistant Listing Number: 84.038

Federal Award Identification Number and Year: N/A – Prior Perkins Awards

Award Period: July 1, 2022 to June 30, 2023

Type of Finding: Significant Deficiency in Internal Control over Compliance, Other Matters

Criteria or Specific Requirement: The Code of Federal Regulations, 34 CFR 674.19.(e)(4)(iii), states that after the loan obligation is satisfied, the institution shall return the original or a true and exact copy of the note marked "paid in full" to the borrower, or otherwise notify the borrower in writing that the loan is paid in full, and retain a copy for the full prescribed period.

Condition: The College did not retain a copy of the note marked "paid in full" in the records of the retired or assigned loans.

Questioned Costs: None.

Context: During our testing, we noted that the college did not retain a copy of the note marked "paid in full." for six of the ten retired or assigned loans tested.

Cause: The College did not retain a copy of the note in the file.

Effect: The College is not in compliance with the record retention requirements.

Repeat Finding: No.

Recommendation: We recommend the college implement a checklist to reference to ensure all required elements of the Perkins loan records are retained as required.

Views of Responsible Officials and Planned Corrective Action: Management agrees with the finding and has developed a plan to correct it.

BUSINESS AFFAIRS AND HUMAN RESOURCES
APRIL 17-18, 2024

UNIVERSITY OF IDAHO

SUBJECT

University of Idaho Utility Public Private Partnership – Amended and Restated Concession Agreement

REFERENCE

April 16, 2020	The Board of Regents reviewed the University of Idaho’s potential Public-Private Partnership as an informational item.
November 2, 2020	The Board of Regents approved the Long Term Lease and Concession Agreement for the University of Idaho Utility System between the University of Idaho and Sacyr Plenary Utility Partners Idaho LLC.
February 15, 2023	The University of Idaho provided an update on the utility P3 for the Board of Regents and notified the Board of upcoming amendments.

APPLICABLE STATUTE, RULE, OR POLICY

Idaho State Board of Education Governing Policies & Procedures, Section V.I.3.

BACKGROUND/DISCUSSION

After the approval of the Board of Regents, the University of Idaho (UI) executed a Long-Term Lease and Concession Agreement (Concession Agreement) under which UI received an up-front payment of \$225,000,000 in exchange for UI leasing its Utility System assets, including operation and the exclusive right to perform capital improvements to infrastructure to Sacyr Plenary Utility Partners Idaho LLC (SPUPI) beginning on December 30, 2020.

As discussed with the Board in November 2020, numerous benefits accrue to UI as a result of this transaction. The upfront consideration, after defeasing \$35 million in bond debt on utility assets, has been invested in a separate single-purpose entity, aptly named the Strategic Initiatives Fund (SIF), that will distribute at least \$6,000,000 annually (depending on market performance of SIF investment assets) from the corpus and earnings of the upfront consideration to fund the University’s strategic initiatives to drive enrollment growth, provide scholarship opportunities to students, and grow the research enterprise as we march towards R1 status. Additionally, UI benefits from having a world-class operator, McKinstry, that leverages its expertise and experience in energy infrastructure to operate and maintain the utility system. Finally, the Concessionaire is required to submit an annual Five-Year Plan, proposing capital improvements that UI can approve at its sole discretion that will be financed over 20 years.

This transaction has been transformational for the University, and UI will continue to update the Board of Regents annually on the current status of utility system

BUSINESS AFFAIRS AND HUMAN RESOURCES
APRIL 17-18, 2024

operations and capital improvements, financial outcomes, the SIF, and student outcomes from SIF investment in student success, marketing, and the pursuit of R1. UI has also provided a detailed annual utility P3 update in the INFORMATIONAL section of the April 2024 Board meeting agenda.

After three years of operations under the Concession Agreement, the University and the Concessionaire have identified technical specifications, inefficiencies, market conditions, and other operational realities that warrant amendment to ensure the longevity of the agreement and mutually intended benefits to both parties.

The proposed amendments fall into five primary categories:

- Insurance – Article 13
- Technical Operation Performance Standards – Schedule 2
- Key Performance Indicators – Schedule 15
- Utility Fee Calculations – Article 7 and Schedule 5
- Capital Improvement Funding – Article 4

Insurance - Amendment to Article 13 (Attachment 1)

One feature of the Concession Agreement is the transfer of operational and casualty risk for the Utility System to SPUPI. To mitigate this risk, the Concession Agreement requires SPUPI to obtain All Risk Property Insurance for the Utility System, unless such insurance is not available at commercially reasonable rates. The cost of insurance premiums is passed on to the University as part of the Utility Fee that the University pays SPUPI.

The United States is experiencing a “hard” property insurance market, causing not only rapidly escalating premiums and tightened underwriting standards, but also carriers’ unwillingness to write policies. As a result, at the inception of the Concession Agreement, SPUPI’s insurance broker was unable to place coverage for the Utility System on a commercially reasonable basis. The University and SPUPI originally addressed this issue by entering into a Pre-Closing Agreement that required SPUPI to pay the premium for the University’s share of the All Risk Property policy purchased by the State of Idaho Risk Management Program on a statewide basis, in lieu of SPUPI obtaining its own policy. Under the Pre-Closing Agreement, SPUPI pays an equivalent portion of the premium and cannot pass on that premium cost to the University. The Pre-Closing Agreement has been extended two times, due to the continuing hard market. (Attachment 10)

Recently, SPUPI reported that its broker is still unable to place coverage for the Utility System. Further, the State of Idaho Risk Management program has notified the University that certain capital assets in the Utility System are and will continue to be excluded from policy that the State of Idaho Risk Management Program will obtain. Thus, the Pre-Closing Agreement no longer bridges the gap in coverage caused by the current hard market.

BUSINESS AFFAIRS AND HUMAN RESOURCES
APRIL 17-18, 2024

To address the problem, the University and SPUPI have agreed to amend the Concession Agreement to create a mechanism for paying for repairs and replacements if there is a casualty to uninsured assets in the Utility System.

In summary, the proposed amendment provides:

- SPUPI shall continue to seek coverage on a commercially reasonable basis and report to the University annually on its efforts.
- The terms under which State of Idaho Risk Management and the University of Idaho may retain risk at its discretion.
- SPUPI will pay the University a monthly payment (the costs cannot be passed on to the University) to compensate the University for the assumption of some of the risk of loss above \$1,000,000 of loss per casualty event for Uninsured Property (no coverage from the State of Idaho or a commercial carrier and agreed upon by the University).
- A process for determining compensation to the University for retention of risk based on the Valuation of Uninsured Property.

Technical Operational Performance Standards – Amendment to Schedule 2 (Attachment 2 – Attachment 7)

Schedule 2 of the Concession Agreement outlines general performance standards and standards of operations, including procedures and delineation of responsibility for activities like emergency response, design standards, compliance with regulations, vehicle use, employee safety, and information technology. Additionally, Schedule 2 includes specific performance standards for the eight utilities operated by the Concessionaire: 1) Chilled Water, 2) Steam and Condensate, 3) Electric, 4) Domestic Water, 5) Compressed Air, 6) Storm Water, 7) Sanitary Sewer, and 8) Reclaimed Water. Each of the eight utility systems has specific requirements unique to that utility, such as pressure, temperature, voltage, etc., as well as efficiency, metering, quality, and regulatory requirements. This section of the Concession Agreement also specifies the lines of demarcation that explain where the University's responsibility ends and the Concessionaire's begins, design standards, and definitions of Unplanned Outages for each specific utility.

The proposed amendment reflects three years of collaboration between UI and SPUPI to clarify the intent and meaning of the language, rectify any inaccuracies, and align the language to the actual operations of the Utility System.

In summary, the proposed amendment provides:

- Clarification and consistency of the lines of demarcation for the eight utilities.
- Updates to performance standards to improve accuracy and measurability, while aligning them to drive optimal performance of the system.

BUSINESS AFFAIRS AND HUMAN RESOURCES
APRIL 17-18, 2024

- Updates to data collection and retention requirements to ensure actionable data is available without unnecessary measurement and retention.
- Updated measurement methodologies and locations for performance data.
- Elimination of redundant Unplanned Outage definitions that inhibit desired performance.
- Updated regulatory requirements to align with state and federal law.
- Updates to performance expectations and Unplanned Outage definitions to ensure maximum electrical output from the newly installed microturbines.
- Elimination of the SCADA System Performance Standard Section (the underlying system belongs to the University) and a complete redrafting of the section to outline the roles and responsibilities.
- Updates and revisions to Appendix G System Operating Efficiency Reporting to reflect more meaningful and measurable metrics.

Key Performance Indicators – Amendment to Schedule 15 (Attachment 9)

Schedule 15 of the Concession Agreement defines Key Performance Indicators (KPI) and calculation methodologies for KPIs and KPI Compensation to the University in the instance of a KPI Event. For each of the eight utilities, the KPIs are based on availability of the utility service as compared to the Total Possible Connection Hours (Availability KPI) and consist of two types of KPI Events: 1) A KPI calculation based on the number of hours of availability and 2) A KPI calculation based on the number of unique Unplanned Outages. Compensation to the University in a given fiscal year increases as the number of hours for which the utility was unavailable increases and as the number of unique Unplanned Outages increases. Compensation increases for consecutive years of KPI Events for the same utility. There are two tables for each utility illustrating the progression.

The lack of clarity for the definition of Total Possible Connection Hours was the primary impetus for these amendments to Schedule 15. One interpretation was that Total Possible Connection Hours should be calculated by multiplying the number of hours in a day by the number of days in a year for each utility. Another interpretation was that Total Possible Connection Hours should be calculated by multiplying the number of hours in a day by the number of days in a year by the number of buildings. With the current KPI tables, the former would disproportionately disadvantage the Concessionaire, requiring it to pay disproportionate KPI Compensation for short Unplanned Outages and encouraging it to propose expensive and unnecessary Capital Improvements and additional maintenance costs to avoid outages and minimize Compensation Events. These costs would be passed on to the University. The latter would disproportionately disadvantage the University by diluting the KPIs 100-fold, rendering them pointless and without the necessary incentives to ensure that the Concessionaire prioritizes availability of utility service to our campus. The intent of the proposed amendment to Schedule 15 is to clarify the definition of Total Possible Connection Hours by defining the calculation methodology (the basis on which percentage of availability of each utility is calculated each fiscal year) and

BUSINESS AFFAIRS AND HUMAN RESOURCES
APRIL 17-18, 2024

then align Target availability, KPI Event thresholds, and compensation with the clarified definition and the operational realities of our Utility System.

In summary, the proposed amendment provides:

- A clear definition of Total Possible Connection Hours.
- The addition of Criticality Factors for each building which adjust compensation for less critical building to encourage prioritization of more critical buildings during Unplanned Outages.
- Clarity on KPI Calculations for multiple outages caused by a single root cause.
- Changes to KPI Calculations for Targets, thresholds for increased compensation, and KPI Compensation to align with the accurate definition of Total Possible Connection Hours.
- Change from percentages to hours as the method of calculation for KPIs for ease and to reduce discrepant interpretation.

**Utility Fee Calculations – Amendment to Article 7 and Schedule 5
(Attachment 1 and Attachment 8)**

The Utility Fee is the established compensation to the Concessionaire for Utility Services. The Utility Fee includes a Fixed Fee, a Variable Fee Component, and an Operating Fee. The Variable Fee Component accounts for the Capital Improvements approved by the University and paid back over 20 years upon completion of the Capital Improvement. The Variable Fee Component is a calculated financing cost using a Return on Equity Factor and a Cost of Debt Factor to account for the return on the Unrecovered Capital expended to perform the approved Capital Improvements. Schedule 5 and Article 7 outline an annual forecast of the fees on which the subsequent fiscal year's fees are based, with an annual reconciliation. This is disadvantageous to the University because the University may prepay for capital that may not be expended, only to recover the overpayment up to 12 months later. The University may also incur Incremental Financing Costs for capital expended due to the Utility Fee not being updated until many months later. The proposed amendments to these sections revise the reconciliation period to a Fiscal Year Half. The requirement of a mid-year reconciliation increases the accuracy of the Utility Fee, reducing both overpayment and Incremental Financing Costs.

Capital Improvement Funding – Article 4 (Attachment 1)

Article 4 of the Concession Agreement describes the process and conditions under which the Concessionaire shall perform Capital Improvements and Material Changes to the Utility System, a responsibility and right guaranteed in Section 2.1. This is an essential component of the Concessionaire's business model of which the revenues were an important consideration in determining the amount of the Upfront Consideration granted to the University upon closing. However, recent

BUSINESS AFFAIRS AND HUMAN RESOURCES
APRIL 17-18, 2024

appropriations for the improvement of infrastructure have exceeded expectations but were unavailable to be used for utility improvements due to the Concession Agreement language. The proposed amendment to Article 4 provides an exception to the exclusive right to perform capital improvements to infrastructure in instances where the University has approved \$8,000,000 per fiscal year in the three prior fiscal years and has received appropriations for Capital Improvements that exceed \$10,000,000 and are 200% greater than the prior year's appropriation.

IMPACT

The proposed amendment will provide necessary updates to a 50-year agreement, providing clarity and efficiencies for the remaining 47 years of the concession. The shift to the University and State Risk of some of the casualty risk that would normally have been borne by the Concessionaire's insurance carrier is necessary due to the current hard market conditions and is intended to be a short-term solution until the Concessionaire is able to procure coverage as intended by the agreement. Under the circumstances, however, the allocation of risk is fair, and the University is compensated for accepting some of the risk. SPUPI will not obtain a windfall or unfair economic advantage because 1) repair and replacement of uninsured assets will not be paid through the Utility Fee, and 2) SPUPI will pay the University an amount similar to what SPUPI would have paid in premiums and will not pass that cost on to the University. The amendment will also improve operational efficiency by clarifying technical performance standards and clearly defining performance expectations and compensation for KPI Events. The KPIs are now aligned to drive performance without driving up capital and operational costs. Amendments to allow the University flexibility in funding Capital Improvements and additional opportunities to update the Utility Fee will provide the University additional avenues to improving the Utility System and reduce financing costs to the institution.

The Concession Agreement has provided \$225,000,000 to the University for its key strategic initiatives that will benefit our students and drive research and innovation at the University of Idaho for the next 47 years. The University proposes this amendment as a means of continuing the fruitful partnership with SPUPI.

ATTACHMENTS

- Attachment 1 – Amended & Restated Concession Agreement
- Attachment 2 – Amended & Restated Performance Standards (Schedule 2)
- Attachment 3 – Original Appendix G (Schedule 2)
- Attachment 4 – Revised Appendix G (Schedule 2)
- Attachment 5 – Original Appendix L (Schedule 2)
- Attachment 6 – Revised Appendix L (Schedule 2)
- Attachment 7 – Appendix BB (Schedule 2)
- Attachment 8 – Amended and Restated Utility Fee (Schedule 5)
- Attachment 9 – Amended and Restated Key Performance Indicators (Schedule 15)
- Attachment 10 – Third Pre-Closing Agreement

BUSINESS AFFAIRS AND HUMAN RESOURCES
APRIL 17-18, 2024

BOARD STAFF COMMENTS AND RECOMMENDATIONS

The Board of Regents approved a public-private partnership (P3) in November 2020 establishing a Long Term Lease and Concession Agreement for the University of Idaho Utility System between the University of Idaho and Sacyr Plenary Utility Partners Idaho LLC. The agreement has provided the University of Idaho with an innovative strategy to both address deferred maintenance as well as providing investment capital for the University’s strategic investments.

Over the past several years of operating under the original Concession Agreement, the University and the Concessionaire have identified technical issues, inefficiencies, market forces, and operational challenges that warrant revisiting to ensure the mutually intended benefits continue for both parties.

The proposed amendments fall into five (5) primary categories:

1. Insurance
2. Technical Operation Performance Standards
3. Key Performance Indicators
4. Utility Fee Calculations
5. Capital Improvement Funding

Staff have reviewed all updated documentation related to the Restated Concession Agreement. The First Amended and Restated Long Term Lease and Concession Agreement has been negotiated and endorsed by University of Idaho’s leadership and its legal counsel. Board approval would be based on the representations and recommendations of the University of Idaho.

BOARD ACTION

I move to approve the First Amended and Restated Long Term Lease and Concession Agreement by and between The Regents of the University of Idaho and Sacyr Plenary Utility Partners Idaho LLC, dated as of November 2, 2020 in substantial conformity with the terms and conditions presented to The Board of Regents on April 17, 2024, and to authorize the University of Idaho’s Vice-President for Finance and Administration to execute and deliver documents in connection therewith.

Moved by _____ Seconded by _____ Carried Yes _____ No _____

FIRST AMENDED AND RESTATED
LONG-TERM LEASE AND CONCESSION AGREEMENT FOR
THE UNIVERSITY OF IDAHO UTILITY SYSTEM

dated as of

~~November 2~~ [____], ~~2020~~2024

by and between

THE REGENTS OF THE UNIVERSITY OF IDAHO

and

SACYR PLENARY UTILITY PARTNERS IDAHO LLC

TABLE OF CONTENTS

	<u>Page</u>
ARTICLE 1 DEFINITIONS AND INTERPRETATION.....	2
Section 1.1. Definitions.....	2
Section 1.2. Number and Gender.....	29 <u>32</u>
Section 1.3. Headings.....	29 <u>32</u>
Section 1.4. References to this Agreement.....	29 <u>32</u>
Section 1.5. References to Any Person.....	29 <u>32</u>
Section 1.6. Meaning of Including.....	29 <u>32</u>
Section 1.7. Meaning of Discretion.....	30 <u>32</u>
Section 1.8. Meaning of Notice.....	30 <u>32</u>
Section 1.9. Consents and Approvals.....	30 <u>32</u>
Section 1.10. Trade Meanings.....	30 <u>32</u>
Section 1.11. Laws.....	30 <u>32</u>
Section 1.12. Currency.....	30 <u>32</u>
Section 1.13. Generally Accepted Accounting Principles.....	30 <u>33</u>
Section 1.14. Calculation of Time.....	30 <u>33</u>
Section 1.15. Approvals, Consents and Performance by the University.....	30 <u>33</u>
Section 1.16. Incorporation of Schedules.....	32 <u>34</u>
Section 1.17. References to Agreements Generally.....	32 <u>34</u>
Section 1.18. Cost Responsibilities.....	32 <u>34</u>
Section 1.19. Out-of-Pocket Costs.....	32 <u>34</u>
Section 1.20. Amendment and Restatement.....	32 <u>35</u>
ARTICLE 2 THE TRANSACTION; CLOSING; CONDITIONS PRECEDENT; COVENANTS.....	32 <u>35</u>
Section 2.1. Grant of Concession.....	32 <u>35</u>
Section 2.2. Closing.....	33 <u>36</u>
Section 2.3. Deposit.....	34 <u>37</u>
Section 2.4. Conditions Precedent; Termination.....	35 <u>38</u>
Section 2.5. Covenants.....	40 <u>43</u>
Section 2.6. Intended Treatment for Federal and State Income Tax Purposes.....	46 <u>49</u>
Section 2.7. Closing Deliverables.....	48 <u>52</u>
Section 2.8. Memorandum of Lease.....	48 <u>52</u>
Section 2.9. No Return of Closing Consideration.....	49 <u>52</u>
ARTICLE 3 TERMS OF THE CONCESSION.....	49 <u>52</u>
Section 3.1. Quiet Enjoyment and Present Condition.....	49 <u>52</u>
Section 3.2. Utility System Operations.....	50 <u>54</u>
Section 3.3. Operator.....	54 <u>57</u>
Section 3.4. Authorizations; Qualifications.....	57 <u>61</u>
Section 3.5. No Encumbrances.....	58 <u>61</u>
Section 3.6. Single Purpose Covenants; Credit Rating.....	59 <u>62</u>

TABLE OF CONTENTS
 (continued)

	<u>Page</u>
Section 3.7. Rights of the University to Access and Perform Work on the Utility System and Utilize Space for Energy Resources and Research Purposes.....	59 <u>63</u>
Section 3.8. Payment of Taxes.....	63 <u>67</u>
Section 3.9. Utilities.....	64 <u>68</u>
Section 3.10. Notices of Defaults and Claims.....	65 <u>69</u>
Section 3.11. Assignment of Operating Agreements and Plans; Project Intellectual Property.....	66 <u>69</u>
Section 3.12. Use of Information and Records.....	68 <u>72</u>
Section 3.13. Standard of Operation and Maintenance of the Utility System; Warranty Period Utility System Projects.....	69 <u>73</u>
Section 3.14. Payments by the University.....	70 <u>73</u>
Section 3.15. Naming and Signage Rights, Other Revenue Activities and Commercial Advertisements and Activities.....	70 <u>74</u>
Section 3.16. Reversion of Utility System.....	71 <u>75</u>
Section 3.17. Police, Fire, Emergency and Public Safety Access Rights.....	71 <u>75</u>
Section 3.18. Negotiations with Third Parties.....	71 <u>75</u>
Section 3.19. Administration of the Public Way.....	72 <u>76</u>
Section 3.20. Rights to Adjacent Space.....	72 <u>76</u>
Section 3.21. Sole Utility Provider.....	72 <u>76</u>
Section 3.22. Repair and Maintenance of the Tunnels.....	73 <u>76</u>
Section 3.23. Adjustments to the Location or Configuration of the Utility System.....	73 <u>77</u>
Section 3.24. Sales to Individual Customers on the University Campus.....	74 <u>77</u>
Section 3.25. University Business Continuity Plan.....	74 <u>78</u>
Section 3.26. Utility System Tours.....	74 <u>78</u>
Section 3.27. Uniforms.....	74 <u>78</u>
Section 3.28. EAC.....	74 <u>78</u>
Section 3.29. Sustainability.....	74 <u>78</u>
Section 3.30. University Utility System Employees.....	75 <u>79</u>
Section 3.31. Office Space.....	75 <u>79</u>
Section 3.32. Utility System Space in Larger Buildings.....	76 <u>79</u>
ARTICLE 4 CAPITAL IMPROVEMENTS AND MATERIAL CHANGES.....	76 <u>80</u>
Section 4.1. Concessionaire Responsibility for Capital Improvements.....	76 <u>80</u>
Section 4.2. Authorizations Related to Capital Improvements.....	76 <u>81</u>
Section 4.3. Approval of Capital Improvements and Material Changes.....	77 <u>82</u>
Section 4.4. University's Capital Plan.....	81 <u>86</u>
ARTICLE 5 MODIFICATIONS.....	81 <u>86</u>
Section 5.1. University Directives.....	81 <u>86</u>
Section 5.2. Performance of Modifications.....	82 <u>87</u>
Section 5.3. Addition, Removal and Lease of Property.....	82 <u>87</u>

TABLE OF CONTENTS
 (continued)

	<u>Page</u>
ARTICLE 6 PERFORMANCE STANDARDS.....	83 <u>88</u>
Section 6.1. Compliance with Performance Standards.....	83 <u>88</u>
Section 6.2. Proposed Performance Standards.....	83 <u>88</u>
Section 6.3. Modified Performance Standards.....	83 <u>89</u>
Section 6.4. Post-Closing Transition Period Assessment.....	85 <u>90</u>
ARTICLE 7 UTILITY FEE, FIVE-YEAR PLAN, AND ENERGY SUPPLY.....	85 <u>90</u>
Section 7.1. Utility Fee.....	85 <u>90</u>
Section 7.2. Five-Year Plan.....	88 <u>93</u>
Section 7.3. Energy and Water Supply.....	90 <u>95</u>
Section 7.4. Energy Use Intensity Reduction and Energy Conservation Measures.....	91 <u>97</u>
ARTICLE 8 REPORTING; AUDITS; INSPECTIONS.....	92 <u>97</u>
Section 8.1. Reports; Environmental Incident Management.....	92 <u>97</u>
Section 8.2. Information.....	93 <u>99</u>
Section 8.3. Inspection, Audit and Review Rights of the University.....	94 <u>100</u>
Section 8.4. Audits, Assistance, Inspections and Approvals.....	95 <u>101</u>
ARTICLE 9 REPRESENTATIONS AND WARRANTIES.....	96 <u>101</u>
Section 9.1. Representations and Warranties of the University.....	96 <u>101</u>
Section 9.2. Representations and Warranties of the Concessionaire.....	99 <u>105</u>
Section 9.3. Non-Waiver.....	101 <u>107</u>
Section 9.4. Survival.....	101 <u>107</u>
ARTICLE 10 FINANCE OBLIGATIONS.....	102 <u>108</u>
Section 10.1. Concessionaire’s Obligations.....	102 <u>108</u>
Section 10.2. University’s Obligations.....	102 <u>108</u>
Section 10.3. Concessionaire’s Obligation for Estoppel Certificates.....	103 <u>109</u>
Section 10.4. Prohibited Tax Shelter Transactions.....	103 <u>109</u>
ARTICLE 11 COMPLIANCE.....	103 <u>109</u>
Section 11.1. Compliance with Laws.....	103 <u>109</u>
Section 11.2. Non-Discrimination.....	104 <u>110</u>
Section 11.3. Compliance with Wage and Hour Laws.....	104 <u>110</u>
Section 11.4. Safety Laws.....	104 <u>110</u>
Section 11.5. Immigration Laws.....	104 <u>111</u>
Section 11.6. Labor Disputes.....	104 <u>111</u>
Section 11.7. Employee Conduct and Performance.....	105 <u>111</u>
Section 11.8. Non-Collusion.....	105 <u>111</u>
Section 11.9. Conflict of Interest.....	105 <u>111</u>
Section 11.10. Drug-Free Workplace Certification.....	105 <u>111</u>
Section 11.11. Minority-Owned and Women-Owned Business Enterprises.....	105 <u>112</u>

TABLE OF CONTENTS
 (continued)

	<u>Page</u>
Section 11.12. University Accreditation.....	106 <u>112</u>
Section 11.13. Permits and Other Campus-Wide Authorizations.....	106 <u>112</u>
Section 11.14. Financial and Audit Standards.....	106 <u>112</u>
Section 11.15. University Payments.....	106 <u>113</u>
ARTICLE 12 PAYMENT OBLIGATIONS.....	107 <u>113</u>
Section 12.1. Certain Payment Obligations of the Concessionaire.....	107 <u>113</u>
Section 12.2. Certain Payment Obligations of the University.....	107 <u>113</u>
Section 12.3. Agency for Representatives.....	108 <u>114</u>
Section 12.4. Third Party Claims.....	108 <u>114</u>
Section 12.5. Direct Claims.....	109 <u>115</u>
Section 12.6. Failure to Give Timely Notice.....	109 <u>115</u>
Section 12.7. Reductions and Subrogation.....	109 <u>115</u>
Section 12.8. Payment and Interest.....	110 <u>116</u>
Section 12.9. Limitation on Certain Claims.....	110 <u>116</u>
Section 12.10. Other Matters.....	110 <u>116</u>
Section 12.11. Offset Rights; Limitations on Certain Damages.....	111 <u>117</u>
Section 12.12. Governmental Immunity.....	111 <u>117</u>
Section 12.13. Survival.....	111 <u>117</u>
ARTICLE 13 INSURANCE.....	111 <u>117</u>
Section 13.1. Insurance Coverage Required – Concessionaire.....	111 <u>117</u>
Section 13.2. Insurance Coverage Required – University.....	114 <u>120</u>
Section 13.3. Additional Requirements.....	115 <u>121</u>
Section 13.4. Damage and Destruction.....	119 <u>127</u>
Section 13.5. Additional University Requirements.....	123 <u>136</u>
ARTICLE 14 ADVERSE ACTIONS.....	123 <u>137</u>
Section 14.1. Adverse Action.....	123 <u>137</u>
Section 14.2. Termination.....	125 <u>138</u>
Section 14.3. Right of the University to Remedy.....	126 <u>139</u>
Section 14.4. Other Actions by Governmental Authorities.....	126 <u>140</u>
Section 14.5. Regulatory Filings.....	127 <u>140</u>
ARTICLE 15 DELAY EVENTS; CONCESSION COMPENSATION AND KPI COMPENSATION.....	127 <u>140</u>
Section 15.1. Delay Events.....	127 <u>140</u>
Section 15.2. Notice of Compensation Events and KPI Events.....	129 <u>142</u>
Section 15.3. Payments of Concession Compensation and KPI Compensation.....	129 <u>143</u>
Section 15.4. KPI Compensation.....	130 <u>144</u>
Section 15.5. Maximum Annual Amount of KPI Compensation.....	131 <u>144</u>

TABLE OF CONTENTS
 (continued)

	<u>Page</u>
ARTICLE 16 DEFAULTS.....	131 <u>144</u>
Section 16.1. Default by the Concessionaire.....	131 <u>144</u>
Section 16.2. Default by the University.....	134 <u>148</u>
Section 16.3. Consequences of Termination or Reversion.....	137 <u>150</u>
Section 16.4. Termination Other than Pursuant to Agreement.....	139 <u>153</u>
ARTICLE 17 RESTRICTIONS ON TRANSFERS.....	140 <u>153</u>
Section 17.1. Transfers by the Concessionaire.....	140 <u>153</u>
Section 17.2. Assignment by the University.....	142 <u>155</u>
ARTICLE 18 DISPUTE RESOLUTION.....	142 <u>155</u>
Section 18.1. Scope.....	142 <u>155</u>
Section 18.2. Informal Dispute Resolution Procedures.....	142 <u>155</u>
Section 18.3. Mediation	142 <u>Dispute Resolution 156</u>
Section 18.4. Litigation.....	143 <u>157</u>
Section 18.5. Provisional Remedies.....	143 <u>157</u>
Section 18.6. Tolling.....	143 <u>157</u>
ARTICLE 19 LENDERS.....	143 <u>157</u>
Section 19.1. Leasehold Mortgages.....	143 <u>157</u>
Section 19.2. Notices and Payments to Leasehold Mortgagees.....	145 <u>159</u>
Section 19.3. Leasehold Mortgagee’s Right to Cure.....	145 <u>159</u>
Section 19.4. Rights of the Leasehold Mortgagee.....	146 <u>160</u>
Section 19.5. Termination of this Agreement; New Agreement.....	147 <u>161</u>
Section 19.6. Recognition of Leasehold Mortgagee.....	148 <u>162</u>
Section 19.7. University’s Right to Purchase Leasehold Mortgages.....	149 <u>163</u>
Section 19.8. Assignment and Assumption Agreement.....	150 <u>164</u>
Section 19.9. Right to Dispute Resolution.....	152 <u>166</u>
ARTICLE 20 MISCELLANEOUS.....	152 <u>166</u>
Section 20.1. Notice.....	152 <u>166</u>
Section 20.2. Entire Agreement.....	154 <u>168</u>
Section 20.3. Amendment.....	155 <u>169</u>
Section 20.4. Waiver of Rights.....	155 <u>169</u>
Section 20.5. Severability.....	155 <u>169</u>
Section 20.6. Governing Law; Waiver of Jury Trial.....	155 <u>169</u>
Section 20.7. Submission to Jurisdiction.....	155 <u>169</u>
Section 20.8. Further Acts.....	156 <u>170</u>
Section 20.9. Costs.....	156 <u>170</u>
Section 20.10. Interest.....	156 <u>170</u>
Section 20.11. Inurement and Binding Effect.....	156 <u>170</u>
Section 20.12. No Partnership or Third Party Beneficiaries.....	156 <u>170</u>

TABLE OF CONTENTS
(continued)

	<u>Page</u>
Section 20.13. Cumulative Remedies.....	156 <u>170</u>
Section 20.14. Counterparts; Electronic Execution.....	157 <u>171</u>
Section 20.15. Time of the Essence.....	157 <u>171</u>

SCHEDULES

Schedule 1	Form of Board Resolution
Schedule 2	Performance Standards
Schedule 3	Utility Facilities, Utility System Land and Utility System Assets
Schedule 4	[Intentionally Omitted]
Schedule 5	Utility Fee
Schedule 6	Existing Supply Contracts
Schedule 7	Form of Legal Opinion of Counsel to the University
Schedule 8	Form of Legal Opinion of Counsel to the Concessionaire
Schedule 9	Financial Information
Schedule 10	Permitted University Encumbrances
Schedule 11	Ongoing Utility System Projects
Schedule 12	Computer Systems and Software
Schedule 13	Form of Memorandum of Lease
Schedule 14	University Withheld Payments
Schedule 15	Key Performance Indicators
Schedule 16	University Campus
Schedule 17	Underground Tunnels
Schedule 18	Campus-Wide Permits
Schedule 19	Section 1060 Allocation Schedule
Schedule 20	Form of Trademark License Agreement
Schedule 21	Main Campus
Schedule 22	North Farm
Schedule 23	Warranty Period Utility System Projects

FIRST AMENDED AND RESTATED
LONG-TERM LEASE AND CONCESSION AGREEMENT FOR
THE UNIVERSITY OF IDAHO UTILITY SYSTEM

THIS FIRST AMENDED AND RESTATED LONG-TERM LEASE AND CONCESSION AGREEMENT FOR THE UNIVERSITY OF IDAHO UTILITY SYSTEM (this “Agreement”) is made and entered into as of this 2nd [] day of ~~November, 2020~~[], 2024 by and between The Regents of the University of Idaho (the “University”) and SACYR PLENARY UTILITY PARTNERS IDAHO LLC, a Delaware limited liability company (the “Concessionaire”).

RECITALS¹

WHEREAS, the ~~University has established a Utility System Parties~~ (as defined herein) ~~and owns or leases (as applicable) the Utility Facilities and the Utility System Assets (both, as defined herein); and~~ entered into that certain Long-Term Lease and Concession Agreement for the University of Idaho Utility System (the “Original Agreement”) dated as of November 2, 2020 (the “Signing Date”);

WHEREAS, pursuant to the Original Agreement, the Parties closed on the Transaction (as defined herein) on December 30, 2020 (the “Closing Date”);

WHEREAS, pursuant to Article IX, Section 10 of the Constitution of the State of Idaho, and Idaho Code Section 33-2801 *et seq.*, the University ~~is~~was authorized to ~~enter into~~close on the Transaction; ~~and, which it subsequently did;~~

WHEREAS, the University, as part of the procurement process described in the University of Idaho P3 Utility System Transaction Request for Proposal Submission dated June 26, 2020 ~~(as, as subsequently modified and~~ amended ~~or modified, the “Request for Proposals”)~~ has, and selected the Concessionaire as the winning bidder for the long-term lease and concession of the Utility System (as described herein) based on the Concessionaire’s performance in relation to the evaluation criteria established by the University; ~~and~~

WHEREAS, the Concessionaire desires to lease the Utility Facilities and the Utility System Land from the University and receive an exclusive grant from the University to operate, maintain, possess, control and improve the Utility System for the Term (as defined herein) of this Agreement, all as hereinafter provided; ~~and~~

WHEREAS, the University has determined that the engagement of the Concessionaire under this Agreement will, among other things, further its energy efficiency and sustainability goals, provide a mechanism for capital improvements as needed, permit the more efficient operation of the Utility System, and advance the overall educational purposes of the University, and, therefore, desires to lease the Utility Facilities and the Utility System Land to the Concessionaire and provide the Concessionaire the exclusive right to operate, maintain, possess,

¹ NTD: Changes to the Recitals are necessary to lay out the reason for the amending and restating the Original Agreement.

control and improve the Utility System for the Term of this Agreement, all as hereinafter provided;~~and~~

WHEREAS, the Concessionaire agrees to lease the Utility Facilities and to operate, maintain, possess, control and improve the Utility System in accordance with the provisions of this Agreement, including the Performance Standards (as defined herein);~~and~~

WHEREAS, the Concessionaire agrees to provide the Utility Services (as defined herein) to the University and to engage in the Utility System Operations pursuant to the terms and conditions of this Agreement; and

WHEREAS, the Parties desire to amend and restate the Original Agreement as hereinafter set forth.

NOW THEREFORE, for and in consideration of the promises, the mutual covenants, representations, warranties and agreements contained herein and other valuable consideration, the receipt and sufficiency of which are hereby acknowledged, the Parties (~~as defined herein~~) covenant and agree to amend and restate the Original Agreement in its entirety to read as follows:

ARTICLE 1 DEFINITIONS AND INTERPRETATION

Section 1.1. Definitions. Unless otherwise specified or the context otherwise requires, for the purposes of this Agreement the following terms have the following meanings:“AA-Compensation” has the meaning ascribed thereto in Section 14.1(b).

“AA-Dispute Notice” has the meaning ascribed thereto in Section 14.1(c).

“AA-Notice” has the meaning ascribed thereto in Section 14.1(c).

“AA-Preliminary Notice” has the meaning ascribed thereto in Section 14.1(c).

“AAA” means the American Arbitration Association.

“Actual Knowledge of the University” means the actual, current knowledge of the University’s Vice President for Finance and Administration or the University’s Assistant Vice President, Facilities on any date which a relevant representation or warranty is made, with the duty for each of the foregoing to inquire of his or her direct reports within 5 Business Days prior to the date of such representation or warranty regarding the relevant matter, but without any other duty of inquiry or investigation.

“Additional Coverages” has the meaning ascribed thereto in Section 13.3(m).

“Adjusted for Inflation” means adjusted by the arithmetic average of the percentage increases, if any, or decreases, if any, in the CPI Index during the most recent adjustment period as specified herein.

“Adverse Action” has the meaning ascribed thereto in Section 14.1(a).

“Affiliate”, when used to indicate a relationship with a specified Person, means a Person that, directly or indirectly, through one or more intermediaries (i) has a 50% or more voting or economic interest in such specified Person or (ii) controls, is controlled by or is under common control with (which shall include, with respect to a managed fund or trust, the right to direct or cause the direction of the management and policies of such managed fund or trust as manager, advisor, supervisor, sponsor or trustee pursuant to relevant contractual arrangements) such specified Person, provided that a Person shall be deemed to be controlled by another Person if controlled in any manner whatsoever that results in control in fact by that other Person (or that other Person and any Person or Persons with whom that other Person is acting jointly or in concert), whether directly or indirectly and whether through share ownership, a trust, a contract or otherwise (for purposes of this definition, a managed fund or trust shall be deemed to be an Affiliate of the Person managing, supervising, sponsoring or advising such fund or trust and a limited partner in a managed fund or trust shall be deemed to be an Affiliate of such fund or trust and of the Person managing, supervising, sponsoring or advising such fund or trust).

“Agreement” has the meaning ascribed thereto in the preamble hereto (including all Schedules referred to herein), as amended from time to time in accordance with the terms hereof.

“Annual Savings” has the meaning ascribed thereto in Section 7.1(c).

“Annual Savings Incentive” has the meaning ascribed thereto in Section 7.1(c).

“Approved Five-Year Plan” means the Five-Year Plan then in effect pursuant to Section 7.2.

“Approval”, “Approved”, “Approves”, “Approved by the University” and similar expressions mean approved or consented to by the University in accordance with the provisions of Section 1.15.

“Arboretum Well” means the parcel identified on Part 1 of Schedule 3 as the “Well” adjacent to building #085 and associated improvements installed therein.

“Assignment and Assumption Agreement” has the meaning ascribed thereto in Section 19.8(c).

“Assumed Liabilities” has the meaning ascribed thereto in Section 3.2(d).

“Audit and Review” and similar expressions mean, with respect to any matter or thing relating to the Utility System, the Utility System Operations or this Agreement, the performance by or on behalf of the University of such reviews, investigations, inspections and audits relating to such matter or thing as the University may reasonably determine to be necessary in the circumstances, conducted in each case in accordance with Prudent Industry Practices, if any, or as required by Law, and in accordance with the provisions of this Agreement.

“Authorization” means any approval, certificate of approval, certification, authorization, consent, waiver, variance, exemption, declaratory order, exception, license, filing, registration,

permit, franchise, notarization or other requirement of any Person that applies to the Utility System or is reasonably required from time to time for the Utility System Operations, including any of the foregoing issued, granted, given or otherwise made available by or under the authority of any Governmental Authority or pursuant to any applicable Law.

“Bank Rate” means SOFR (or any successor rate thereto) as reported in the *Wall Street Journal* (or any successor thereof).

“Baseline Capped O&M Costs” means, for a Fiscal Year (the “Relevant Fiscal Year”), Capped O&M Index for the first Fiscal Year during the Term, but excluding the costs and expenses attributable to payroll and benefits due to employees that were engaged in the operations and maintenance of the Utility System, (a) adjusted for inflation calculated by reference to the applicable CPI Index in each subsequent Fiscal Year up to and including the Relevant Fiscal Year and (b) increased by the forecasted annual operations and maintenance costs during the Relevant Fiscal Year which are attributable to all Approved Capital Improvements and Material Changes that have been brought into service at any time prior to the end of the Relevant Fiscal Year (to the extent that such forecasted costs were included in the Approval for such New Approved Capital Improvements or Material Changes, as applicable), *provided* that the foregoing shall be calculated in accordance with the illustrative example set out in Exhibit A of Schedule 5.

“Bid Date” means October 14, 2020.

“Breakage Costs” means any breakage costs, make-whole premium payments, termination payments or other prepayment amounts (including debt premiums and interest rate hedge termination costs) that are required to be paid by the Concessionaire with respect to Leasehold Mortgage Debt as a result of the early repayment (including, following acceleration) of such Leasehold Mortgage Debt prior to its scheduled maturity date.

“Business Day” means any Day that is neither a Saturday, a Sunday nor a Day observed as a holiday by the University; provided, that solely with respect to the timing of any payment obligation under this Agreement, a Business Day shall also not be a Day on which banks that are members of the United States federal reserve system are permitted or required to be closed.

“Campus-Wide Permits” means the Authorizations set forth on Schedule 18, as each may be extended, renewed, modified or replaced.

“Capital Improvement” means any improvement to or replacement or expansion of the components of the Utility Facilities, Tunnels or Shared Spaces that is capital in nature, as determined in accordance with GAAP.

“Capital Recovery Amount” has the meaning ascribed thereto in Schedule 5.

“Capped O&M Ceiling” has the meaning ascribed thereto in Schedule 5.

“Capped O&M Costs”² means the following specifically identified out-of-pocket operating and maintenance costs and expenses incurred by the Concessionaire (which costs and expenses shall include payments due and payable by the Concessionaire to the Operator or other Contractors pursuant to an Operating Agreement or similar agreement) or the Operator in operating the Utility System and complying with their respective obligations under this Agreement, without duplication: (i) the charges as described in [Section 3.9\(a\)](#); (ii) the professional expenses, salaries, employee benefits and bonuses paid or granted to employees and contractors of the Concessionaire or the Operator to perform any of the Utility System Operations and including the costs of issuing and administering requests for proposals in connection with the procurement of subcontractors; (iii) the cost of the supplies (other than Supplies) reasonably necessary to possess, control, operate and manage the Utility System and used exclusively in connection therewith, specifically, (1) office supplies, (2) motor vehicle supplies, (3) safety supplies, (4) uniforms, (5) computer supplies, (6) telecommunication equipment, (7) measuring and testing equipment and instruments, (8) radios, pagers, cell phones and similar communication equipment, (9) gas containers and (10) hand tools; (iv) postage and delivery charges; (v) long-distance and local telephone call charges; (vi) internet access charges; (vii) repair and maintenance of any of the Utility System Assets or Utility Facilities to the extent incurred in accordance with Prudent Industry Practices (including, for the avoidance of doubt, the cost to dispose of ash and other waste products generated by the Utility System Operations); (viii) legal fees directly related to the operation of the Utility System and specifically excluding legal fees associated with the negotiation of this Agreement, [the Original Agreement](#) or the Trademark License Agreement, any amendment or modification thereto or any dispute with the University in connection with this Agreement, [the Original Agreement](#), the Trademark License Agreement, the Utility System Operations or the Transaction; (ix) design, energy auditing and engineering services (other than in connection with any University Directive); (x) janitorial services for the Utility Facilities; (xi) seminar and training costs for employees of the Concessionaire or the Operator; (xii) service vehicles exclusively used in the performance of Utility System Operations; (xiii) insurance charges for the insurance that the Concessionaire is required to carry pursuant to [Article 13](#); (xiv) lease and rental charges other than any payments paid by the Concessionaire to the University for the lease of the Utility System; (xv) the costs of performing inspections required by the Performance Standards; (xvi) the costs incurred in connection with utility coordination pursuant to [Section 3.9\(b\)](#); (xvii) the costs of compliance with the Campus-Wide Permits to the extent applicable to the Utility System; (xviii) other selling, general and administrative expenses but only to the extent that such expenses would be properly included in a cost of service rate regulated by the Federal Energy Regulatory Commission and are not specifically identified as Uncapped O&M Costs; (xix) payments to the Operator pursuant to the agreement between the Concessionaire and the Operator to operate the Utility System pursuant to this Agreement (including, for the avoidance of doubt, any operator fee payable to the Operator under such operating agreement, subject to the limitations set forth in [Section 3.3](#)); (xx) the costs for the Operator to be a member of any regulatory program, to the extent required by Law or this Agreement; (xxi) the costs for any Authorizations for the Concessionaire or Operator to perform the Utility System Operations, to the extent required by Law including those costs paid to the University for an Authorization that the University uses to pay the applicable Governmental Authority; (xxii) the professional fees and expenses relating to

² [NTD: Changes to this definition are necessary to confirm there are no costs associated with the Original Agreement or this A&R Agreement.](#)

the preparation of audited financial statements of the Concessionaire for purposes of Section 8.1(c); (xxiii) the cost and expense paid to the applicable Credit Rating Agency for maintaining the credit rating required by Section 3.6 (provided that, for the first 3 Fiscal Years (and any partial Fiscal Year) after Closing, this cost shall be treated as Uncapped O&M Costs and shall not be included in the calculation of the Capped O&M Index, and after such period will be added to the Capped O&M Index in accordance with Section 3.6); and (xxiv) the costs incurred to comply with Section 3.22 (other than any Capital Improvements, which shall be subject to Article IV); provided that, in no event, shall Capped O&M Costs include any costs or expenses incurred by the Concessionaire or the Operator that result from the negligence or willful misconduct of, or violation of applicable Law by, the Concessionaire or the Operator.

“Capped O&M Index” has the meaning ascribed thereto in Schedule 5.

~~“Cash Deposit” has the meaning ascribed thereto in Section 2.3(a).~~

“Casualty Cost” has the meaning ascribed thereto in Section 13.4(a)(ii).

“Change in Control”³ means, with respect to any Person, whether accomplished through a single transaction or a series of related or unrelated transactions and whether accomplished directly or indirectly, any of (i) a change in ownership so that 50% or more of the direct or indirect voting or economic interests in such Person (calculated as of the Signing Date) is transferred to a Person or group of Persons acting in concert, (ii) the power directly or indirectly to direct or cause the direction of management and policy of such Person; (calculated as of the Signing Date), whether through ownership of voting securities, by contract, management agreement, or common directors, officers or trustees or otherwise, is transferred to a Person or group of Persons acting in concert or (iii) the merger, consolidation, amalgamation, business combination or sale of substantially all of the assets of such Person; provided, however, that notwithstanding anything to the contrary set forth in this definition, none of the following shall constitute a Change in Control for the purposes of this Agreement:

- (a) Transfers of direct or indirect ownership interests in the Concessionaire between or among Persons that are majority-owned Affiliates of each other or Persons who are under common control, whether directly or indirectly and whether through share ownership, a trust, a contract or otherwise;
- (b) Transfers of equity of the Concessionaire or of the direct or indirect owners of the Concessionaire pursuant to bona fide open market transactions on the New York Stock Exchange, NASDAQ, London Stock Exchange, Toronto Stock Exchange or comparable U.S. or foreign securities exchange, including any such transactions involving an initial or “follow on” public offering of direct or indirect equity holders of the Concessionaire; provided that no Person (that is not an Equity Participant or its beneficial owner having ownership interests in the Concessionaire as of the ~~date hereof~~Signing Date) or group of Persons acting in concert (that is not an Equity Participant or its beneficial owner having

³ NTD: Changes to this definition are necessary to ensure that this A&R Agreement does not substantively change what a “Change in Control” is.

ownership interests in the Concessionaire as of the ~~date hereof~~Signing Date) acquires securities such that such Person or group of Persons beneficially owns more than 50% of the publicly traded securities of the Concessionaire;

- (c) Transfers of direct or indirect ownership interests in the Concessionaire by any Equity Participant or its beneficial owners to any Person so long as the Equity Participants or their respective beneficial owners having ownership interests in the Concessionaire as of the ~~date hereof~~Signing Date together retain, in the aggregate, (1) 50% or more of the direct or indirect voting or economic interests in the Concessionaire or (2) the power to directly or indirectly direct or cause the direction of management and policy of the Concessionaire, whether through ownership of voting securities, contract or management agreement or common directors, officers or trustees or otherwise;
- (d) Any change of ownership that is attributable to a lease, sublease, concession, management agreement, operating agreement or other similar arrangement that is subject and subordinate in all respects to the rights of the University under this Agreement so long as (1) no Change in Control occurs with respect to the Concessionaire, and (2) the Concessionaire remains obligated under this Agreement;
- (e) The creation of a trust or any other transaction or arrangement that is solely a transfer of all or part of the Concessionaire's economic interest under this Agreement to another entity so long as (1) no Change in Control occurs with respect to the Concessionaire, and (2) the Concessionaire remains obligated under this Agreement;
- (f) Transfers of direct or indirect ownership interests in the Concessionaire (1) between or among investment funds, including funds that invest in infrastructure, and investors therein; provided that, following such Transfer, such direct or indirect ownership interests remain under the same common ownership, management or control as existed prior to such Transfer, or (2) from investment funds, including infrastructure funds, or investors therein, to any Person; provided that such direct or indirect ownership interests, following the consummation of such Transfer, remain under the same management or control that existed prior to such Transfer, it being understood that ownership interests shall be deemed to be controlled by a Person if controlled in any manner whatsoever that results in control in fact, whether directly or indirectly, and whether through share ownership, a trust, a contract or otherwise; and
- (g) Mergers between an Equity Participant and a third party, provided that, immediately prior to such merger, the equity interests of both parties are publicly traded in open market transactions on the New York Stock Exchange, NASDAQ, London Stock Exchange, Toronto Stock Exchange or comparable U.S. or foreign securities exchange.

“Chilled Water Tank (Thermal Energy Storage)” means the building identified as building #748 on Part 1 of Schedule 3 and associated improvements installed therein that is currently used for the storage of 2.0 million gallons chilled water supporting commonly known as the “Thermal Energy Storage Tank (TES),” which stores chilled water that is in turn distributed across the University Campus through the General Chilled Water Portion of the Utility System (as defined in Schedule 15).

“Chip Facility Scale House” means the building identified as building #761 on Part 1 of Schedule 3 and associated improvements installed therein.

“Chip Storage/Drying Facility” means the building identified as building #758 on Part 1 of Schedule 3 and associated improvements installed therein.

“Claim” means any demand, action, cause of action, suit, proceeding, arbitration, claim, judgment or settlement or compromise relating thereto which may give rise to a right to a payment obligation under Section 12.1 or Section 12.2.

“Closing” has the meaning ascribed thereto in Section 2.2(a).

“Closing Consideration” has the meaning ascribed thereto in Section 2.1.

“Closing Date” has the meaning ascribed thereto in Section 2.2(a).

“Closing Deposit” has the meaning ascribed thereto in Section 2.3(a).

“Closing Period” means the period between the ~~date hereof~~Signing Date up to the Time of Closing.⁴

“Code” means the Internal Revenue Code of 1986, as amended from time to time. Any reference in this Agreement to a particular provision of the Code shall be interpreted to include a reference to any corresponding provision of any successor statutes.

“Comparable Utility Systems” means with respect to any component of the Utility System, a utility system producing and/or delivering any of the Utilities (whether privately or publicly owned) that is located at a large university, is used in connection with providing such utility services to such university, its employees, customers and visitors and is reasonably comparable to the relevant component of the Utility System in terms of physical structure, capacity, utilization and the nature of the services provided, provided that the University and the Concessionaire may designate by written agreement one or more utility systems as “Comparable Utility Systems”.

“Compensation Calculation Date” means (i) every 3rd June 30 during the Term, commencing as of June 30, 2024, (ii) the date of removal of the Operator pursuant to Section 3.3(c)(ii), (iii) the first June 30 after any date on which one Party notifies the other Party

⁴ NTD: Changes from “date hereof” to the “Signing Date” throughout are necessary to ensure there are no unintended changes in the time period of the relevant statement.

that it, in good faith, believes that the Concession and KPI Compensation Balance would exceed \$1,000,000 if calculated on the date of such notice and (iv) the End Date.

“Compensation Calculation Measuring Period” means (i) with respect to the first Compensation Calculation Date, the period commencing on (a) the Closing Date, for Concession Compensation and (b) the Day immediately following the Post-Closing Transition Period, for KPI Compensation, and, in each case expiring on such Compensation Calculation Date, and (ii) with respect to each subsequent Compensation Calculation Date, the period between such Compensation Calculation Date and the immediately preceding Compensation Calculation Date.

“Compensation Event” means (i) subject to Article 5, the Concessionaire’s compliance with or the implementation of any University Directive or any modified or changed Performance Standard subject to Section 6.3(b), provided that it shall not be a Compensation Event if the costs or reduction in revenue incurred in connection therewith will be recovered by the Concessionaire pursuant to the calculation and payment of the Utility Fee; (ii) the occurrence of an Adverse Action; (iii) the occurrence of an event causing a delay described in the definition of “Delay Event” but only to the extent that the Utility Fee is reduced by a Delay Event caused by such event pursuant to Section 15.1(c); (iv) the occurrence of those certain events described under Section 3.7(a) and Section 3.7(e) which are expressly identified as requiring the payment of Concession Compensation; (v) the University distributing or permitting any third party to distribute on the University Campus, any Utility, except as permitted by Section 3.21; (vi) the Concessionaire incurring any Losses as a result of failing to obtain, or being unreasonably delayed in obtaining, or failing to promptly renew or maintain in good standing, an Authorization from the University that is necessary to comply with Law, despite the Concessionaire’s use of its reasonable best efforts to obtain, promptly renew or maintain in good standing such Authorization, and such failure or delay could not have been reasonably prevented by commercially reasonable technical, scheduling or other measures of the Concessionaire; (vii) any action of the Idaho Public Utilities Commission or the Federal Energy Regulatory Commission or their successors, that subjects the Concessionaire to such agency’s regulatory jurisdiction due solely to the Utility System Operations performed in accordance with this Agreement and has a material adverse effect on the fair market value of the Concessionaire Interest (whether as a result of a decrease in the Utility Fee or other revenues or increased expenses that cannot be recovered pursuant to this Agreement or both), except where such action is in response to any act or omission on the part of the Concessionaire that is illegal (other than an act or omission rendered illegal by virtue of the agency’s action) or such action is otherwise permitted under this Agreement and such designation as a Compensation Event shall be the Concessionaire’s sole right and remedy with respect to any action by the Idaho Public Utilities Commission or the Federal Energy Regulatory Commission (or their successors) subjecting a Person to its jurisdiction in connection with the Utility System; (viii) the occurrence of any other event that under the terms of this Agreement expressly requires the payment of Concession Compensation or (ix) any increase in the number of University Utility System Employees from the Setting Date until the Closing Date to the extent such additional University Utility System Employees are employed by the Concessionaire or Operator immediately after the Closing Date.

“Concession Compensation” means any amount payable by the University to the Concessionaire in order to restore the Concessionaire to the same economic position the Concessionaire would have enjoyed if the applicable Compensation Event had not occurred,

which amount, for any Compensation Calculation Date, shall be calculated as the sum of (i) all Losses for the applicable Compensation Calculation Measuring Period (including increased O&M Costs (which, for the avoidance of doubt, shall be regardless of the Capped O&M Ceiling) and financing costs but excluding any costs and expenses (including O&M Costs) that the Concessionaire is able to recover through the payment of the Utility Fee) plus (ii) the actual and estimated net losses of the Utility Fee for the applicable Compensation Calculation Measuring Period that is reasonably attributable to such Compensation Event; provided, however, that with respect to clause (ii), the amount of such actual and estimated net losses that may be claimed at any Compensation Calculation Date shall not exceed the amount of actual and estimated net losses of the Utility Fee suffered during, and attributable only to, such Compensation Calculation Measuring Period (including the inability to make Capital Improvements that the University had Approved); provided, further, that with respect to clause (ii), the amount of such actual and estimated net losses reasonably attributable to such Compensation Event and suffered during, and attributable only to, a future Compensation Calculation Measuring Period may be claimed as Concession Compensation for such future Compensation Calculation Measuring Period only during such future Compensation Calculation Measuring Period in accordance with Article 15. Concession Compensation, if any, shall be paid in accordance with Article 15 and shall not be subject to any limitations on the amount of the Utility Fee including the Capped O&M Ceiling. If the Concessionaire elects to provide its own capital for a Capital Improvement with respect to compliance with any Compensation Event that is not recoverable by the Concessionaire pursuant to the Utility Fee, then the Concession Compensation, shall, in addition to the components described above, take into account a return on such capital equal to the Return on Equity Factor.

“Concession and KPI Compensation Balance” means, at each Compensation Calculation Date, (i) Concession Compensation due and payable with respect to such Compensation Calculation Measuring Period pursuant to the terms of this Agreement less (ii) the sum of all KPI Compensation due and payable with respect to such Compensation Calculation Measuring Period pursuant to the terms of this Agreement, plus (iii) the Concession and KPI Compensation Balance (which may be negative) for the preceding Compensation Calculation Measuring Period if carried forward pursuant to Section 15.3(e).

“Concessionaire” has the meaning ascribed thereto in the preamble to this Agreement.

“Concessionaire Default” has the meaning ascribed thereto in Section 16.1(a).

“Concessionaire Interest” means the interest of the Concessionaire in the Utility System created by this Agreement and the rights and obligations of the Concessionaire under this Agreement.

“Concessionaire Required Coverages” has the meaning ascribed thereto in Section 13.1.

“Concessionaire Retained Casualty” means a casualty affecting the Utility System (i) that is caused by the willful misconduct of the Concessionaire, the Operator, or any Contractor of the Concessionaire that is primarily responsible for the ongoing Utility System Operations or any of their Affiliates or any Equity Participant or any of their Affiliates, (ii) for which the Concessionaire carries insurance in accordance with Section 13.1 that is intended to cover the loss caused by such casualty, (iii) wherein the affected portion of the Utility System had been

declined to be defined as Uninsured Utility System Property by the University pursuant to Section 13.3(u)(iii) or (iv) wherein the affected Utility System is Uninsured Utility System Property that the Concessionaire elected to not have covered pursuant to Section 13.3(u)(iii).

“Concessionaire’s Parent” means the Person, if any, that directly owns, and only owns, 100% of the shares of capital stock, units, partnership or membership interests, other equity interests and equity securities, to the extent applicable, of the Concessionaire.

“Consent” means any approval, consent, ratification, waiver, exemption, franchise, license, permit, novation, certificate of occupancy or other authorization of any Person, including any Consent issued, granted, given or otherwise made available by or under the authority of any Governmental Authority or pursuant to any applicable Law.

“Contractor” means, with respect to a Person, any contractor with whom such Person contracts to perform work or supply materials or labor in relation to the Utility System, including any subcontractor of any tier, supplier or materialman directly or indirectly employed pursuant to a subcontract with a Contractor. For the avoidance of doubt, the Operator (if other than the Concessionaire) shall be a Contractor of the Concessionaire.

“CPI Index” means the “Consumer Price Index – West Urban, All Items” (not seasonally adjusted) as published by the U.S. Department of Labor, Bureau of Labor Statistics; provided, however, that if the CPI Index is changed so that the base year of the CPI Index changes, the CPI Index shall be converted in accordance with the conversion factor published by the U.S. Department of Labor, Bureau of Labor Statistics; provided further, that if the CPI Index is discontinued or revised during the Term, such other index or computation with which it is replaced shall be used in order to obtain substantially the same result as would be obtained if the CPI Index had not been discontinued or revised.

“Credit Rating Agencies” means Standard & Poor’s Rating Services, Fitch Investors Service, Inc. or Moody’s Investor Services, or their successors or Affiliates, provided that if any of the foregoing and any of their successors cease to exist, the University shall, by written notice to the Concessionaire, identify other credit rating agencies as the “Credit Rating Agencies” that, at such time, are Nationally Recognized Statistical Rating Organizations as determined and defined by the United States Securities and Exchange Commission or their equivalents.

“Day” means a calendar day, beginning at midnight in the pacific time zone of the United States coinciding with the calendar day.

“Defending Party” has the meaning ascribed thereto in Section 12.4(c).

“Delay Event” means (i) an event of Force Majeure that interrupts, limits or otherwise adversely affects the performance of the Concessionaire’s obligations hereunder or the Concessionaire’s use of all or any material part of the Utility System; (ii) a failure to obtain, or delay in obtaining, any Authorization from a Governmental Authority (provided that such failure or delay could not have been reasonably prevented by technical and scheduling measures or other reasonable measures of the Concessionaire); (iii) the enactment of a new Law or the modification, amendment or change in enforcement or interpretation of a Law (including a change in the application or implementation thereof by any Governmental Authority) arising

after the Setting Date; (iv) a delay caused by the performance of works (including the activities authorized by Section 3.7) carried out by the University or at its direction or, for purposes of Delay Events only (and not Compensation Events), by any other Person not acting under the authority or direction of the Concessionaire or the Operator; (v) a delay caused by a failure by the University to perform or observe any of its covenants or obligations under this Agreement; (vi) a delay caused by the presence in, on, under, over or around the Utility System of Hazardous Substances, which, in each case, results in or would result in a delay or interruption in the performance by the Concessionaire of any obligation under this Agreement and which Hazardous Substances were not caused to be in, on, under, over or around the Utility System by the Concessionaire, the Operator or any of their respective Representatives; (vii) a delay in providing the Utility Services caused by the failure of a third party or the University to provide any of the inputs into the Utility System that would be included in the definition of “Supplies”; (viii) subject to Section 9.4(a), a delay caused by a breach by the University of its representations and warranties set forth herein; (ix) a writ, decree or injunction that precludes or prevents the performance of the Concessionaire’s obligations hereunder or the Concessionaire’s use of all or any material part of the Utility System; (x) the discovery at or about the site of construction required or permitted to be undertaken pursuant to this Agreement of legally protected plant or animal species or archaeological, paleontological or cultural resources; or (xi) a written notice or direction from a Governmental Authority specifically requiring the Concessionaire to cease all or a material part of the Utility System Operations due to a failure to comply with applicable Law and such failure is because the Utility System Operations are not in compliance with Law due directly and primarily to the fact that the University unreasonably withheld its Approval to a Capital Improvement or Material Change that, if Approved, would have caused Utility System Operations to comply with the relevant Law to which such notice or direction from a Governmental Authority relates. For the avoidance of doubt, a Delay Event shall not include any event of which the consequence is otherwise specifically dealt with in this Agreement or arises by reason of (A) the negligence or willful misconduct of, or violation of applicable Law by, the Concessionaire, the Operator or any of their respective Representatives, (B) any act or omission by the Concessionaire or its Representatives in breach of the provisions of this Agreement, (C) any strike, labor dispute or other labor protest involving any Person retained, employed or hired by the Concessionaire or its Representatives to supply materials or services for or in connection with the Utility System Operations or any strike, labor dispute or labor protest pertaining to the Concessionaire, in all cases to the extent that such strike, dispute or protest (1) is not of general application and (2) is caused by or attributable to any act (including any pricing or other practice or method of operation) or omission of the Concessionaire or its Representatives or (D) lack or insufficiency of funds or failure to make payment of monies or provide required security on the part of the Concessionaire, unless such lack or insufficiency of funds or such failure is caused by another relevant Delay Event.

“Delay Event Remedy” has the meaning ascribed thereto in Section 15.1(d).

“Delay Event Remedy Dispute Notice” has the meaning ascribed thereto in Section 15.1(e).

“Delay Event Remedy Notice” has the meaning ascribed thereto in Section 15.1(e).

“Depository” means a savings bank, a savings and loan association or a commercial bank or trust company which would qualify as an Institutional Lender, designated by the Concessionaire, that enters into an agreement with the Concessionaire to serve as depository pursuant to this Agreement, provided that such Depository shall have an office, branch, agency or representative located in at least one of the City of Moscow, Idaho or the City of Boise, Idaho; provided, however, that so long as a Leasehold Mortgage is in effect, the Depository under Section 13.4 shall be the institution acting as the collateral agent or depository under the financing secured by such Leasehold Mortgage, whether or not it has an office, branch, agency or representative located in the City of Moscow, Idaho; provided, however, with respect to a Depository designated under Section 13.4(b)(i)(B), such Depository shall be designated by the University but the University may designate the collateral agent or depository under the financing secured by such Leasehold Mortgage to act as the Depository.

“DEQ” has the meaning ascribed thereto in Section 11.13.

“Designated Senior Person” means such individual or individuals who are designated as such from time to time by each Party for the purposes of Article 18 by written notice to the other Party, which may be changed at any time by written notice from such Party to the other Party. Initially, the Designated Senior Person for the University will be the University’s Vice President for Finance and Administration and the Designated Senior Persons for the Concessionaire will be Matthew Coady and Raúl Perez Lopez.

“Direct Claim” means any Claim by an Obligee against an Obligor that does not result from a Third Party Claim.

“Disclosure Schedules” means the following Schedules: Schedule 3, Schedule 6, Schedule 9, Schedule 10, Schedule 11, Schedule 12, Schedule 14, Schedule 16, Schedule 17, Schedule 18, Schedule 21, Schedule 22 and Schedule 23.

“Dispute Notice” has the meaning ascribed thereto in Section 15.3(b).

“Document” has the meaning ascribed thereto in Section 1.15(b).

“EAC” means the Energy Advisory Committee to be formed by the University to provide input to the University with respect to the operation and use of the Utility Facilities. The membership and voting procedures of the EAC shall be determined by the University, in its discretion, provided that at least one member shall be a Representative of the Concessionaire.

“Eligible Investments” means any one or more of the following obligations or securities: (i) direct obligations of, and obligations fully guaranteed by, the United States of America or any agency or instrumentality of the United States of America, the obligations of which are backed by the full faith and credit of the United States of America; (ii) demand or time deposits, federal funds or bankers’ acceptances issued by any Institutional Lender (provided that the commercial paper or the short-term deposit rating or the long-term unsecured debt obligations or deposits of such Institutional Lender at the time of such investment or contractual commitment providing for such investment have been rated “A” (or the equivalent) or higher by a Credit Rating Agency or any other demand or time deposit or certificate of deposit fully insured by the Federal Deposit Insurance Corporation); (iii) commercial paper (including both non-interest-bearing discount

obligations and interest-bearing obligations payable on demand or on a specified date not more than one Year after the date of issuance thereof) which has been rated “A” (or the equivalent) or higher by a Credit Rating Agency at the time of such investment; (iv) any money market funds, the investments of which consist of cash and obligations fully guaranteed by the United States of America or any agency or instrumentality of the United States of America, the obligations of which are backed by the full faith and credit of the United States of America and which have been rated “A” (or the equivalent) or higher by a Credit Rating Agency; and (v) other investments then customarily accepted by the University in similar circumstances; provided, however, that no instrument or security shall be an Eligible Investment if such instrument or security evidences a right to receive only interest payments with respect to the obligations underlying such instrument or if such instrument or security provides for payment of both principal and interest with a yield to maturity in excess of 120% of the yield to maturity at par.

“Emergency” means (i) an Unplanned Outage or (ii) a situation that is urgent and calls for immediate action, which, if such action is not taken, is reasonably likely to result in imminent harm or physical damage to any or all of the Utility System or any Person, including the University or the Concessionaire.

“Encumbrance” means any mortgage, lien, judgment, execution, pledge, charge, security interest, restriction, easement, servitude, option, reservation, lease, claim, trust, deemed trust or encumbrance of any nature whatsoever, whether arising by operation of Law, judicial process, contract, agreement or otherwise created.

“End Date” means the date on which this Agreement expires or is terminated.

“Energy Plant” means the building identified as building #011 on Part 1 of Schedule 3 and associated improvements installed therein.

“Environment” means soil, surface waters, ground waters, land, stream sediments, surface or subsurface strata and ambient air.

“Environmental Laws” means any Laws applicable to the Utility System or Utility System Operations regulating or imposing liability or standards of conduct concerning or relating to (i) the regulation, use or protection of human health or the Environment or (ii) the presence of or regulation, use or exposure to Hazardous Substances.

“EPA” has the meaning ascribed thereto in Section 11.13.

“Equity Participant” means any Person who holds directly any shares of capital stock, units, partnership or membership interests, other equity interests or equity securities of the Concessionaire.

“Escrow Agent” means a bank, trust company or national banking association selected by the University to hold the Cash Deposit.

“Excluded Liabilities” has the meaning ascribed thereto in Section 3.2(d).

“Facilities Equipment Storage” means the building identified as building #847 on Part 1 of Schedule 3 and associated improvements installed therein.

“Fiscal Year” means the period from July 1 to June 30, provided that if the University adjusts its fiscal year during the Term, the Fiscal Year shall be adjusted to be the same as the University’s fiscal year.

“Fiscal Year Half” means either the Fiscal Year First Half or the Fiscal Year Second Half.

“Fiscal Year First Half” means the period from July 1 to December 31, provided that if the University adjusts its fiscal year during the Term, the Fiscal Year First Half shall be adjusted to be the first six-month period of any Fiscal Year.

“Fiscal Year Second Half” means the period from January 1 to June 30, provided that if the University adjusts its fiscal year during the Term, the Fiscal Year Second Half shall be adjusted to be the second six-month period of any Fiscal Year.

“Five-Year Plan” means the budget and plan prepared by the Concessionaire in accordance with Section 7.2 for the operation of the Utility System and performance of its obligations under this Agreement in respect of (i) the period consisting of the first partial Fiscal Year of the Term and the first 5 full Fiscal Years of the Term, (ii) any given period of exactly 5 full Fiscal Years during the Term or (iii) if fewer than 5 full Fiscal Years remain in the Term, the remaining full and partial Fiscal Years of the Term.

“Fixed Fee” has the meaning ascribed thereto in Schedule 5.

“Force Majeure” means any event beyond the reasonable control of a Party that delays, interrupts or limits the performance of the affected Party’s obligations hereunder, including an intervening act of God or public enemy, war, invasion, armed conflict, act of foreign enemy, blockade, revolution, act of terror, sabotage, civil commotions, interference by civil or military authorities, condemnation or confiscation of property or equipment by any Governmental Authority, nuclear or other explosion, radioactive or chemical contamination or ionizing radiation, fire, tornado, flooding, earthquake or other natural disaster, riot or other public disorder, vandalism, epidemic, quarantine restriction, strike, labor dispute or other labor protest, stop-work order or injunction issued by a Governmental Authority, a governmental embargo or general unavailability or interruption of supplies or products for the construction, operation, maintenance, repair, replacement and renovation of the Utility System.

“Forecast Utility Fee” has the meaning ascribed thereto in Section 7.1(a).

“GAAP” means U.S. generally accepted accounting principles, consistently applied.

“Golf Course Water Tank” means the building identified as building #683 on Part 1 of Schedule 3 and associated improvements installed therein.

“Governmental Authority” means any court, federal, state, local or foreign government, department, commission, board, bureau, agency or other regulatory, administrative, governmental or quasi-governmental authority, which shall not include the University.

“Hazardous Substance” means any solid, liquid, gas, odor, heat, sound, vibration, radiation or other substance or emission which is a contaminant, pollutant, dangerous substance, toxic substance, hazardous waste, subject waste, hazardous material or hazardous substance that is or becomes regulated by applicable Environmental Laws or which is classified as hazardous or toxic under applicable Environmental Laws (including gasoline, diesel fuel or other petroleum hydrocarbons, polychlorinated biphenyls, asbestos, lead-based paint and urea formaldehyde foam insulation).

“I Water Tank” means the building identified as building #682 on Part 1 of Schedule 3 and associated improvements installed therein.

“IFRS” means the International Financial Reporting Standards, consistently applied.

“Initial Five-Year Plan” means the Five-Year Plan in respect of the period set forth in clause (i) of the definition of “Five-Year Plan”.

“Institutional Lender” means (i) the United States of America, any state thereof or any agency or instrumentality of either of them, any municipal agency, public benefit corporation or public authority, advancing or insuring mortgage loans or making payments which, in any manner, assist in the financing, development, operation and maintenance of projects, (ii) any (a) savings bank, savings and loan association, commercial bank, trust company (whether acting individually or in a fiduciary capacity) or insurance company organized and existing under the laws of the United States of America or any state thereof, (b) foreign insurance company or commercial bank qualified to do business as an insurer or commercial bank as applicable under the laws of the United States of America, (c) pension fund, foundation or university or college or other endowment fund or (d) investment bank, pension advisory firm, mutual fund, investment company or money management firm, (iii) any “qualified institutional buyer” under Rule 144(A) under the Securities Act or any other similar Law hereinafter enacted that defines a similar category of investors by substantially similar terms or (iv) any other financial institution or entity designated by the Concessionaire and Approved by the University (provided that such institution or entity, in its activity under this Agreement, shall be acceptable under then current guidelines and practices of the University); provided, however, that each such entity (other than entities described in clause (iii) of this definition) or combination of such entities if the Institutional Lender shall be a combination of such entities shall have individual or combined assets, as the case may be, of not less than \$500,000,000, which shall include, in the case of an investment or advisory firm, assets controlled by it or under management.

“IRWA” has the meaning ascribed thereto in Section 3.3(e).

“Key Performance Indicators” means those requirements and standards for the operation of the Utility System as set forth on Schedule 15.

“KPI Compensation” means the amount of compensation due from the Concessionaire to the University for a KPI Event, which amount for each KPI Event is set forth in Schedule 15.

“KPI Event” has the meaning set forth in Schedule 15, unless such KPI Event is due to a Delay Event, a Compensation Event, a breach of this Agreement by the University, the negligence or willful misconduct of the University or its Representatives, grantees, tenants, contractors, mortgagees, licensees, concessionaires and others claiming by, through, or under the University, or otherwise excused pursuant to this Agreement.

“Law” means any order, writ, injunction, decree, judgment, law, ordinance, decision, opinion, ruling, policy, statute, code, rule or regulation of any Governmental Authority.

“Leasehold Mortgage” means any lease, indenture, mortgage, deed of trust, pledge or other security agreement or arrangement, including a securitization transaction with respect to the Utility Fee or any part thereof, encumbering any or all of the Concessionaire Interest or the shares or equity interests in the capital of the Concessionaire and any of its subsidiaries or any cash reserves or deposits held in the name of the Concessionaire, in each case that satisfies all of the conditions in Section 3.6 and Section 19.1.

“Leasehold Mortgage Debt” means any bona fide debt (including principal, accrued interest, original issue discount and customary lender or financial insurer, agent and trustee fees, costs, premiums, expenses, indemnities and reimbursement obligations (whether liquidated or contingent) with respect thereto, and including all payment obligations under interest rate hedging agreements with respect thereto and reimbursement obligations with respect thereto to any financial insurer) and/or an assignment in connection with a securitization transaction secured by a Leasehold Mortgage relating to the Utility System and granted to a Person pursuant to an agreement entered into prior to the occurrence of any Adverse Action, University Default or any event of termination, cancellation, rescinding or voiding referred to in Section 16.4 giving rise to the payment of amounts for or in respect of termination under this Agreement. For the purposes of determining the Utility System Concession Value, Leasehold Mortgage Debt shall not include (i) debt from an Affiliate of the Concessionaire or the Operator, unless such debt is on terms consistent with terms that would reasonably be expected from a non-Affiliate lender acting in good faith and otherwise complies with the requirements of Leasehold Mortgage Debt set forth above; (ii) any increase in debt to the extent such increase is the result of an agreement or other arrangement entered into after the Concessionaire was aware (or should have been aware, using reasonable due diligence) of the prospective occurrence of an event giving rise to the payment of the Utility System Concession Value; or (iii) any debt with respect to which the Leasehold Mortgagee did not provide the University with notice of its Leasehold Mortgage in accordance, in all material respects, with the Leasehold Mortgagee Notice Requirements.

“Leasehold Mortgagee” means the holder or beneficiary of a Leasehold Mortgage or a trustee or agent acting on behalf of such holder or beneficiary, including the Lessor in a lease or Leveraged Lease.

“Leasehold Mortgage Notice Requirements” means the delivery by a holder or beneficiary of a Leasehold Mortgage to the University, not later than 10 Days after the execution and delivery of such Leasehold Mortgage by the Concessionaire, of a true and complete copy of

the executed original of such Leasehold Mortgage, together with a notice containing the name and post office address of the holder of such Leasehold Mortgage, which may be an agent on behalf of the provider of the Leasehold Mortgage Debt.

“Leasehold Mortgagee’s Notice” has the meaning ascribed thereto in Section 19.7(a).

“Lessor” means a Leasehold Mortgagee that has purchased all or a portion of the Concessionaire Interest and leased that interest in the Concessionaire Interest to the Concessionaire.

“Letter of Credit” means a committed, irrevocable, unconditional, commercial letter of credit, in favor of the University, in form and content reasonably acceptable to the University, payable in U.S. dollars upon presentation of a sight draft and a certificate confirming that the University has the right to draw under such letter of credit in the amount of such sight draft, without presentation of any other Document, which letter of credit (i) is issued by a commercial bank or trust company that is a member of the New York Clearing House Association or the Clearing House Interbank Payments System and that has a current credit rating of A-2 or better by Standard & Poor’s Ratings Services and an equivalent credit rating by another Credit Rating Agency (or such other commercial bank or trust company reasonably acceptable to the University and Approved by the University prior to the submission of the letter of credit) or such other commercial bank or trust company that is Approved by the University, and (ii) provides for the continuance of such letter of credit for a period of at least one Year or as otherwise provided in this Agreement. The office for presentment of sight drafts specified in the Letter of Credit shall be located (a) at a specified street address within at least one of the City of Moscow, Idaho or the City of Boise, Idaho or other location acceptable to the University or (b) at a facsimile number located within the United States.

“Leveraged Lease” means a lease, sublease, concession, management agreement, operating agreement or other similar arrangement in which the Lessor has borrowed a portion of the purchase price of the interest in the Concessionaire Interest acquired by the Lessor and granted to the lenders of those funds a security interest in that interest.

“Long-Term Restoration Payment Plan” has the meaning ascribed thereto in Section 13.4(b)(iii)(B).

“Loss” means, with respect to any Person, any loss, claim, liability, damage, penalty, amount paid pursuant to a settlement, charge or out-of-pocket and documented cost or expense (including fees and expenses of counsel and any Tax losses) actually suffered or incurred by such Person but excluding any punitive, special, exemplary, indirect and consequential damages and any contingent liability until such liability becomes actual, except, for the avoidance of doubt, to the extent the same are part of a Third Party Claim pursuant to Article 12 (provided that, for the avoidance of doubt, an actual loss, claim, liability, damage of any Contractor or Representative of the Concessionaire and for which the Concessionaire is liable subject only to receiving payment in respect thereof from the University, shall not be treated as a contingent liability for this purpose).

“Main Campus” means the portion of the University Campus depicted on Schedule 21.

“Major KPI Event” means, in a ~~KPI Event which obligates the Concessionaire to pay~~ Fiscal Year, any of the following KPI Events where the KPI Compensation ~~to the University, with respect to that KPI Event only, in an amount equal to the greater of (i) \$1,000,000 and (ii) 10% of the Utility Fee~~ due in that Fiscal Year for that KPI Event equals the maximum amount of KPI Compensation for that KPI Event: (a) Electric Hours KPI Calculation, (b) General Steam Hours KPI Calculation, (c) General Chilled Water Events Calculation, (d) Domestic Water Hours Calculation, (e) Sanitary Sewer Events KPI Calculation, (f) Storm Water Events KPI Calculation, (g) Reclaimed Water Hours KPI Calculation, (h) Reclaimed Water Events KPI Calculation, (i) Compressed Air Hours KPI Calculation and (j) Compressed Air Events KPI Calculation.

“Material Adverse Effect” means a material adverse effect (after taking into account contemporaneous material positive effects) on the business, operations, financial condition or results of operations of the Utility System taken as a whole or on the ability of the University to consummate the Transaction or perform any material obligation hereunder; provided, however, that no effect arising out of or in connection with or resulting from any of the following shall be deemed, either alone or in combination, to constitute or contribute to a Material Adverse Effect: (i) general economic conditions or changes therein; (ii) financial, banking, currency or capital markets fluctuations or conditions (either in the United States of America or any international market and including changes in interest rates); (iii) conditions affecting the financial services or utility industries generally; (iv) any existing event or occurrence of which the Concessionaire has actual knowledge as of the Setting Date; (v) any action, omission, change, effect, circumstance or condition contemplated by this Agreement or attributable to the execution, performance or announcement of this Agreement or the Transaction (except for any litigation relating thereto or to this Agreement (or the matters contemplated herein)); and (vi) negligence, intentional misconduct or bad faith of the Concessionaire or its Representatives.

“Material Change” means any material change in the dimensions, character, quality or location of any part of the Utility System that would not be considered Capital Improvements.

“Maximum Annual Operator Fee” has the meaning ascribed thereto in Section 3.3(e).

“Maximum Retained Risk Payment” means an amount equal to \$1,000,000 per occurrence.

“McClure Hall Space” means the portion of the building identified as building #110 on Part 1 of Schedule 3 and associated improvements installed therein, which portion is more particularly identified on Part 2 of Schedule 3.

“Memorandum of Lease” has the meaning ascribed thereto in Section 2.8.

“New Agreement” has the meaning ascribed thereto in Section 19.5(a).

“New Approved Capital Improvement” has the meaning ascribed thereto in Schedule 5.

“New Approved Capital Improvement Cost” has the meaning ascribed thereto in Schedule 5.

“Non-Recurring Savings” means a reduction in the Capped O&M Index for a particular Fiscal Year that is the direct result of significant unusual or infrequently occurring items, as determined in accordance with GAAP or the timing by which recurring Capped O&M Costs are incurred.

“North Farm” means the portion of the University Campus depicted on Schedule 22.

“Notice” has the meaning ascribed thereto in Section 20.1.

“Notice Period” has the meaning ascribed thereto in Section 12.4(b).

“O&M Costs” means, in the aggregate, the Capped O&M Costs and the Uncapped O&M Costs.

“Obligation Payment” has the meaning ascribed thereto in Section 12.7.

“Obligee” means any Person entitled to the benefit of a payment obligation under Article 12.

“Obligor” means any Person obligated to meet a payment obligation under Article 12.

“Offsets” has the meaning ascribed thereto in Section 12.11(a).

“Ongoing Utility System Projects”⁵ means those projects that the University ~~is~~ was undertaking with respect to the Utility System as of the Closing Date that are listed on Schedule 11, ~~provided that the University may, if it completes any such projects prior to the Time of Closing, provide the Concessionaire notice thereof and amend Schedule 11 accordingly.~~

“Operating Agreement” means any material agreement, contract or commitment to which the Concessionaire is a party or otherwise relating to the Utility System Operations as in force from time to time (including any warranties or guaranties), but excluding any Leasehold Mortgage and financing documents related thereto.

“Operating Agreements and Plans” has the meaning ascribed thereto in Section 3.11(a).

“Operations Plan” has the meaning ascribed thereto in Schedule 2.

“Operator” has the meaning ascribed thereto in Section 3.3(a).

“Operator Evaluation Period” means, as applicable, (i) the period commencing on the Day immediately following the Post-Closing Transition Period and ending on the 5-year anniversary thereof or (ii) each subsequent 5-year period after the period described in clause (i). For the avoidance of doubt, such 5-year periods are fixed periods, rather than rolling periods.

“Party” means a party to this Agreement and “Parties” means both of them.

⁵ NTD: Changes to this definition are necessary to reflect the update that the University provided prior to Closing.

“Performance Standards” means the standards, specifications, policies, procedures and processes that apply to the operation of, maintenance of, rehabilitation of and Capital Improvements to the Utility System set forth in Schedule 2 and its appendices (as may be modified pursuant to the terms hereof), including any plans submitted by the Concessionaire to the University as required therein. To the extent that any term or provision set forth in Schedule 2 or incorporated by reference in Schedule 2 conflicts with any term or provision specified in this Agreement, then such term or provision of this Agreement shall govern and shall supersede any such conflicting term or provision.

“Permitted Concessionaire Encumbrance” means, with respect to the Concessionaire Interest: (i) any Encumbrance that is being contested in accordance with Section 3.5(a) (but only for so long as such contest effectively postpones enforcement of any such Encumbrance); (ii) any (A) lien or security interest for obligations not yet due and payable to a Contractor or other Person, (B) statutory lien, deposit or other non-service lien or (C) lien, deposit or pledge to secure mandatory statutory obligations or performance of bids, tenders, contracts (other than for the repayment of borrowed money) or leases, or for purposes of like general nature, any of which are incurred in the ordinary course of business of all or any part of the Utility System Operations and are either (x) not delinquent or (y) which are being contested, or being caused to be contested, by the Concessionaire in accordance with Section 3.5(a) (but only for so long as such contest effectively postpones enforcement of any such Encumbrance); (iii) inchoate materialmen’s, mechanics’, workmen’s, repairmen’s, employees’, carriers’ or warehousemen’s liens or other like Encumbrances arising in the ordinary course of business of all or any part of the Utility System or the Concessionaire’s performance of any of its rights or obligations hereunder, and either (A) are not delinquent or (B) are being contested by the Concessionaire in accordance with Section 3.5(a) (but only for so long as such contest effectively postpones enforcement of any such Encumbrance); (iv) any right reserved to or vested in any Governmental Authority or the University by any statutory provision or under common law (it being understood and agreed that nothing in this clause (iv) shall limit or otherwise affect the University’s obligations or the Concessionaire’s rights hereunder); (v) any other Encumbrance permitted hereunder (including any Leasehold Mortgage (and financing statements or other means of perfection relating thereto)); (vi) liens incurred in the ordinary course of business in connection with workers’ compensation, unemployment insurance, social security and other governmental rules and that do not in the aggregate materially impair the use, value or operation of the Utility System; (vii) any Encumbrances created, incurred, assumed or suffered to exist by the University or any Person claiming through the University; (viii) any Encumbrance, security interest or pledge imposed upon the Concessionaire and any Affiliate as to the Concessionaire’s and any Affiliate’s assets arising from borrowings, financings, leases or similar transactions in the ordinary course of business; (ix) any Encumbrances in existence as of the Closing not caused by the Concessionaire, the Operator or any of their respective Representatives; and (x) any amendment, extension, renewal or replacement of any of the foregoing.

“Permitted University Encumbrance” means: (i) the Concessionaire Interest; (ii) any Encumbrance that is being contested, or being caused to be contested, by the University in accordance with Section 3.5(b) (but only for so long as such contest effectively postpones enforcement of any such Encumbrance); (iii) inchoate materialmen’s, mechanics’, workmen’s, repairmen’s, employees’, carriers’ or warehousemen’s liens or other like Encumbrances arising in the University’s performance of any of its rights or obligations hereunder, and either (A) are

not delinquent or (B) are being contested, or are being caused to be contested, by the University in accordance with Section 3.5(b) (but only for so long as such contest effectively postpones enforcement of any such Encumbrance); (iv) any easement, covenant, condition, right-of-way or servitude (or other similar reservation, right and restriction) or other defects and irregularities in the title to the applicable assets that do not materially interfere with the Utility System Operations or the rights and benefits of the Concessionaire under this Agreement or materially impair the value of the Concessionaire Interest from and after the Closing Date; (v) any zoning, building, environmental, health, safety or other Law; (vi) the police and regulatory powers of the State of Idaho, City of Moscow, Idaho and Latah County, Idaho with respect to the Utility System, and the regulation of the use of the Public Way (it being understood and agreed that nothing in this clause (vi) shall prevent any exercise of such powers being an Adverse Action if it meets the definition thereof); (vii) any right reserved to or vested in any Governmental Authority by any statutory provision or under common law (it being understood and agreed that nothing in this clause (vii) shall prevent any exercise of such right being an Adverse Action if it meets the definition thereof); (viii) any other Encumbrance permitted hereunder; (ix) any Encumbrances created, incurred, assumed or suffered to exist by the Concessionaire or any Person claiming through it (provided that this shall not grant the Concessionaire, or any Person claiming through the Concessionaire, the right to create, incur, assume or suffer to exist any such Encumbrance unless otherwise expressly contemplated herein); (x) any rights reserved to or vested in the University by any statutory provision (it being understood and agreed that nothing in this definition shall limit or otherwise affect the University's obligations or the Concessionaire's rights hereunder); (xi) any of the Encumbrances set forth on Schedule 10; and (xii) any amendment, extension, renewal or replacement of any of the foregoing.

“Person” means any individual (including, the heirs, beneficiaries, executors, legal representatives or administrators thereof), corporation, partnership, joint venture, trust, limited liability company, limited partnership, joint stock company, unincorporated association or other entity or a Governmental Authority, including the University.

“Post-Closing Transition Period” means the period from the Closing Date to the date that is the later of (i) June 30, 2021 and (ii) 5 months after the Closing Date, provided that the Concessionaire may terminate the Post-Closing Transition Period earlier on written notice to the University.

“Project Intellectual Property” has the meaning ascribed thereto in Section 3.11(b).

“Property Taxes” means any ad valorem property Tax attributable to the Utility System or the Concessionaire Interest, including an ad valorem tax on real property and improvements, buildings, structures, fixtures and all tangible personal property.

“Prorated Items” means all revenues, charges, costs and expenses with respect to Assumed Liabilities.

“Prudent Industry Practices” means, at a particular time, those practices, methods, standards and acts which are engaged in and generally accepted by prudent providers of services of the kind contemplated by this Agreement in the United States, taking into account practices, methods and acts in use at Comparable Utility Systems or individual utility facilities forming

part of Comparable Utility Systems, life-cycle maintenance costs and considerations, and the design, engineering, construction, testing, operation and maintenance requirements set out in this Agreement, and which, in the exercise of reasonable judgment at the time the decision was made, could reasonably have been expected to achieve the desired result consistent with applicable Law, safety, reliability, efficiency and expedition. “Prudent Industry Practices” is not intended to be limited to the optimum practice or method to the exclusion of all others, but rather to be a spectrum of reasonable practices, methods, standards and acts.

“Public Way” means the streets, alleys, driveways and sidewalks owned by the University.

“Pump House 3” means the building identified as building #70 on Part 1 of Schedule 3 and associated improvements installed therein.

“Pump House 4” means the building identified as building #089 on Part 1 of Schedule 3 and associated improvements installed therein.

“Pump House 9” means the building identified as building #407 on Part 1 of Schedule 3 and associated improvements installed therein.

“Quarter” means each calendar quarter of each Fiscal Year of the Term.

“Reclaimed Water Chlorination Building” means the building identified as building #771 on Part 1 of Schedule 3 and associated improvements installed therein.

“Reconciliation Statement” has the meaning ascribed thereto in Section 7.1(b).

“Record Retention Policy” has the meaning ascribed thereto in Section 3.12(a).

“Recovery Period” means a period for each New Approved Capital Improvement, commencing at the beginning of the Fiscal Year Half following the Fiscal Year Half in which the applicable New Approved Capital Improvement Costs are incurred and expiring on the expiration of the 20th full Fiscal Year following the commencement of such period, or such other period as agreed by the University and the Concessionaire as part of the University’s Approval of the applicable New Approved Capital Improvement, over which the Concessionaire shall recover the cost of that New Approved Capital Improvement in the Utility Fee pursuant to Schedule 5, as such period may be adjusted pursuant to Section 4.3.

“Release” means depositing, spilling, leaking, pumping, pouring, emitting, discarding, abandoning, emptying, discharging, injecting, escaping, leaching, dumping or disposing of any Hazardous Substances into the Environment.

“Relevant Fiscal Year” has the meaning ascribed thereto in the definition of “Baseline Capped O&M Costs.”

“Repetitive Failure” means a Repetitive Non-Major KPI Event or a Repetitive Performance Standards Failure.

“Repetitive Non-Major KPI Event” means, during any given Operator Evaluation Period, the occurrence of a KPI Event for a particular Key Performance Indicator 3 or more times during such Operator Evaluation Period.

“Repetitive Performance Standards Failure” means, during any given Operator Evaluation Period, the failure to comply with or to meet a distinct requirement of the Performance Standards (provided that the University shall have provided separate written notices for each such failure) 3 or more times during such Operator Evaluation Period.

“Representative” means, with respect to any Person, any director, officer, employee, official, partner, member, owner, agent, lawyer, accountant, auditor, professional advisor, consultant, engineer, Contractor, other Person for whom such Person is at law responsible or other representative of such Person and any professional advisor, consultant or engineer designated by such Person as its “Representative”. For the avoidance of doubt, the Operator (if other than the Concessionaire) shall be deemed a Representative of the Concessionaire.

“Request for Proposals” has the meaning ascribed thereto in the recitals to this Agreement.

“Required Coverages” has the meaning ascribed thereto in Section 13.2.

“Restoration” has the meaning ascribed thereto in Section 13.4(ab)(ii)(A).

“Restoration Funds” has the meaning ascribed thereto in Section 13.4(ab)(iii)(B).

~~“Restoration Shortfall Amount” has the meaning ascribed thereto in Section 13.4(a)(iii).~~

“Reversion Date” means the Business Day immediately following the End Date.

“Revised Proration Statement” has the meaning ascribed thereto in Section 2.2(b)(ii).

“RJA” has the meaning ascribed thereto in Section 9.1(j).

“Schedule” means a schedule attached hereto and incorporated in this Agreement, unless otherwise expressly indicated by the terms of this Agreement.

“Securities Act” means the United States Securities Act of 1933, as amended.

“Senior Officials” has the meaning ascribed thereto in Section 3.3(c)(i)(A).

“Setting Date” means the Day that is 10 Business Days prior to the Bid Date.

“Shared Spaces” has the meaning ascribed thereto in Section 3.32.

“Signing Date” has the meaning ascribed thereto in the Recitals to this Agreement.

“SOFR” means, with respect to any day, the secured overnight financing rate published for such day by the Federal Reserve Bank of New York, as the administrator of the benchmark, (or a successor administrator) on the Federal Reserve Bank of New York’s Website.

“South Campus Chiller Plant” means the building identified as building #749 on Part 1 of Schedule 3 and associated improvements installed therein.

“Special Allocation of Funds” has the meaning ascribed thereto in Section 4.1(a).

“State Risk” means the Idaho Department of Administration Risk Management Program or its successor agency.

“State Risk Retained Casualty” means a casualty affecting the Utility System that (i) is not a Concessionaire Retained Casualty and (ii) affects the portion of the Utility System for which State Risk carries or provides the relevant property insurance.

“Supplies” has the meaning ascribed thereto in Section 7.3(a).

“Supply Contract” has the meaning ascribed thereto in Section 7.3(a).

“Supply Costs” means all out-of-pocket costs incurred in the procurement of Supplies (including any transmission costs, riders or other similar costs reasonably necessary to procure Supplies).

“Target” has the meaning ascribed thereto in Schedule 15.

“Tax” means any federal, state, local or foreign income, gross receipts, commercial activity, license, payroll, employment, excise, severance, stamp, occupation, premium, windfall profits, environmental, customs duties, permit fees, capital stock, franchise, profits, withholding, social security, unemployment, disability, real property, personal property, parking, sales, use, transfer, registration, value added, alternative or add-on minimum, estimated or other tax, levy, impost, stamp tax, duty, fee, withholding or similar imposition of any kind payable, levied, collected, withheld or assessed at any time, including any interest, penalty or addition thereto, whether disputed or not.

“Tax-Advantaged Bond” means any bond that is (i) a bond the interest on which is excluded from gross income for purposes of the Code, (ii) a “Build America Bond” as defined in Section 54AA of the Code, or (iii) a “qualified tax credit bond” as defined in Section 54A of the Code.

“Term” has the meaning ascribed thereto in Section 2.1.

“Termination Damages” has the meaning ascribed thereto in Section 14.2(a).

“Third Party Agreement” has the meaning ascribed thereto in Section 3.18.

“Third Party Capital Improvement” has the meaning ascribed thereto in Section 4.1.

“Third Party Claim” means any Claim asserted against an Obligee by any Person who is not a Party or an Affiliate of such a Party.

“Time of Closing” means 9:00 a.m. Pacific Time on the Closing Date or such other time on that date as that the University and the Concessionaire agree in writing that the Closing shall take place, which the Parties acknowledge occurred on 11:13 a.m. Pacific Time on the Closing Date.

“Title Commitment” has the meaning ascribed thereto in Section 2.4(a)(iii).

“Title Company” means Stewart Title Guaranty Company through Moscow Title, Inc.

“Transaction” has the meaning ascribed thereto in Section 2.1.

“Transfer” means to sell, convey, assign, lease, sublease, mortgage, encumber, transfer or otherwise dispose of.

“Transferee” means any Person who obtains the Concessionaire Interest pursuant to a Transfer.

“Transformer Storage Space” means the portion of the building identified as building #760 on Part 1 of Schedule 3 and associated improvements installed therein which portion is more particularly identified on Part 2 of Schedule 3.

“Tunnels” means the tunnels and other underground passageways where Utility System Assets or Utility Facilities are located as identified on Schedule 17, which Tunnels, for the avoidance of doubt, are part of the Utility System but are not Utility System Land. To the extent that additional tunnels where Utility System Assets or Utility Facilities are located are identified by the Concessionaire or the University after the ~~date hereof~~ Signing Date, the definition of “Tunnels” shall include those later-identified tunnels. For the avoidance of doubt, all vaults and trench-boxes not exclusively used in connection with the Utility System shall be treated as Tunnels.

“Uncapped O&M Costs” means the sum of the following: (1) these specifically identified out-of-pocket operating and maintenance costs and expenses incurred by the Concessionaire (which costs and expenses shall include payments due and payable by the Concessionaire to the Operator or other Contractors pursuant to an Operating Agreement or similar agreement) or the Operator in operating the Utility System and complying with their respective obligations under this Agreement: (a) costs incurred due to a Delay Event, provided that for events described in clause (iii) of the definition of “Delay Event”, Uncapped O&M Costs shall only include those costs (which are not costs incurred to make Capital Improvements) necessary to bring the Utility System into compliance with the applicable Law and not the ongoing costs associated therewith, (b) costs incurred to modify the location or configuration of the Utility System as directed by the University pursuant to Section 3.23 (but only to the extent such costs are not costs incurred to make a Capital Improvement), (c) costs incurred by the Concessionaire pursuant to Section 4.3(c)(ii) if the relevant proposed Capital Improvement or Material Change is not Approved by the University, (d) costs incurred to disconnect real property from the Utility System if required pursuant to Section 5.3(a), (e) costs incurred in connection with a modification to the

Performance Standards pursuant to Section 6.3(a), (f) costs incurred to perform the obligations set forth in Section 7.4, but only to the extent such costs were Approved by the University prior to being incurred, (g) costs incurred to pay Property Taxes, if such costs are included in Uncapped O&M Costs pursuant to Section 3.8, (h) costs incurred to make time-sensitive repairs or improvements to (A) the Utility System or (B) University-owned property related to, but not a part of, the Utility System, in each case to the extent such repairs or improvements (1) are not Capital Improvements, (2) were not contemplated in the most recently approved Five-Year Plan, (3) were either (x) made in the Concessionaire's good-faith belief that they were being made to the Utility System or (y) made in the Concessionaire's good-faith belief that the repair was the best first response to an Emergency, and (4) have been Approved by the University in its discretion, (i) storm water and sanitary effluent charges assessed by the City of Moscow, Idaho, except to the extent that such storm water and sanitary effluent charges increase as a result of an action or inaction of the Concessionaire (other than the actions or inactions that the Concessionaire is directed or obligated to take or omit pursuant to this Agreement, including in order to comply with the Performance Standards), (j) an Approved Capital Improvement that is classified as Uncapped O&M Costs pursuant to Section 4.3(h) or an Approved Material Change (unless such costs are treated as another form of compensation to the Concessionaire provided for in this Agreement in connection with the Approval of such Material Change), in each case up to the amount Approved by the University as part of its Approval of such Capital Improvement or Material Change, (k) costs incurred in connection with Supply procurement assistance under Section 7.3(a) or Section 7.3(b), but only to the extent such costs were Approved by the University prior to being incurred, (l) costs (including KPI Compensation) incurred as a direct result of the Concessionaire's failure to comply with Law or this Agreement if the sole reason for such failure is that the University failed to be reasonable in its Approval of all possible Capital Improvements or Material Changes that would cure or prevent such failure to comply with such Law or this Agreement, (m) costs associated with a University Directive that is not the construction of a Capital Improvement in accordance with Section 5.1, (n) legal fees arising out of any Excluded Liabilities, (o) the costs of any premium or deductible for professional liability insurance coverage procured by the Concessionaire in accordance with Section 13.1(e) for a particular Approved Capital Improvement or Material Change provided that such coverage and the cost thereof is expressly included in the request for Approval of such Capital Improvement or Material Change and the University Approves such cost, (p) all costs identified in the definition of "Capped O&M Costs" related to any Ongoing Utility System Project or New Approved Capital Improvement incurred only during the first 3 full Fiscal Years (and any partial Fiscal Year) after such Ongoing Utility System Project or New Approved Capital Improvement becomes part of the Utility System or is brought into service, as applicable, (q) the operations and maintenance costs that are reasonably necessary to cause the Utility System or Utility System Operations to comply with the enactment of a new Law or the modification, amendment or change in enforcement or interpretation of a Law (including a change in the application or implementation thereof by any Governmental Authority) arising after the Setting Date but solely for the first 3 full Fiscal Years (and any partial Fiscal Year) after the occurrence of such enactment, modification, amendment or change (but not, for the avoidance of doubt, those costs that are included in any other clause of this definition), (r) the reasonable costs that are referenced in the definition of "Capped O&M Costs" as being treated as "Uncapped O&M Costs" for the period of time set forth therein and the reasonable costs of any other adjustments to the Capped O&M Index made pursuant to this Agreement for the first 3 full Fiscal Years (and

any partial Fiscal Year) after such adjustment is first made, and (s) the out-of-pocket costs of providing Utilities from temporary sources for construction projects as identified by the University as described in Section 3.2(a), provided that, for the avoidance of doubt, in no event, shall Uncapped O&M Costs include any costs or expenses incurred by the Concessionaire that result from the negligence or willful misconduct of, or violation of applicable Law by, the Concessionaire or the Operator; and (2) an amount equal to the product of 26.47% (which represents the blended ~~current~~ highest combined state and federal income Tax rate as of the Closing Date⁶ but which, for the avoidance of doubt, shall not change over the Term regardless of any change to federal or state corporate income tax rates) multiplied by the income generated solely by the equity portion of the Variable Fee Component (which for the avoidance of doubt is the amount equal to sub-part (ii)) only in the calculation of the Utility Fee as set forth on Schedule 5 of the Concession Agreement) regardless of the amount of such Taxes actually paid by the Concessionaire.

“Uninsured Utility System Property” means any portion of the Utility System that is not covered by the Required Property Insurance because it is commercially unavailable as described in Section 13.3(o) and neither State Risk nor the University has provided insurance coverage for such portion of the Utility System subject to the University’s rights under Section 13.3(u)(iii). For the avoidance of doubt, the Utility System or any portion thereof shall not be considered Uninsured Utility System Property if Required Property Insurance or property insurance provided by State Risk or the University identifies the Utility System or the relevant portion thereof as an insured asset under the applicable insurance policy regardless of whether the applicable insurer or, in the case of a State Risk Retained Casualty, State Risk, approves or rejects a claim therefor in the event of a casualty with respect thereto.

“University” has the meaning ascribed thereto in the preamble to this Agreement.

“University Campus” means the real property and improvements located thereon that are owned and/or leased by the University, which real property is shown on Part I of Schedule 16 and, solely with respect to the domestic water Utility, and also shown on Part II of Schedule 16, which, for each Utility, shall depict the real property that comprise the “University Campus” for that Utility, and the Parties acknowledge and agree may differ among Utilities, such that when reference is made herein to the “University Campus”, it shall be the University Campus for the relevant Utility.

“University Default” has the meaning ascribed thereto in Section 16.2(a).

“University Directive” means a written order or directive prepared by or on behalf of the University in conformity with the requirements and limitations of this Agreement directing the Concessionaire, to the extent permitted hereby, other than pursuant to Section 3.23, to (i) add to, or perform work in respect of, the Utility System in addition to that provided for in this Agreement (including (a) work within the University Campus on utility facilities or energy equipment that are not and will not be considered part of the Utility System in accordance with the definition thereof, (b) taking control of the internal University billing system for Utilities and

⁶ NTD: The change to this parenthetical is necessary so as not to change this percentage, which was intended to be fixed.

(c) causing the Concessionaire to engage in sustainability practices in excess of those reasonably required by Prudent Industry Practices) or (ii) change the dimensions, character, quantity, quality, description, location or position of any part of the Utility System or make other changes to the Utility System; provided that, notwithstanding the foregoing, (1) as part of any such order or directive or as a separate order or directive, the University may cause certain personal property to be deemed Utility System Assets and part of the Utility System even if such personal property is beyond the line of demarcation for the applicable Utility as set forth in the Performance Standards and may cause the Concessionaire to purchase and/or install such personal property, provided that if any such personal property would be beyond the line of demarcation for the applicable Utility as set forth in the Performance Standards, such order or directive may only be issued with the approval of the Concessionaire, acting reasonably, (2) any such order or directive can include the design, demolition, project management, construction, repair, replacement, remodeling, renovation, reconstruction, enlargement, addition, alteration, painting, or structural or other improvements not included in the Utility Facilities but related thereto, provided that such work must be part of a larger project (as determined by the University in its reasonable discretion) for which the Utility System is the primary driver of such project (as determined by the University in its reasonable discretion), (3) the University may, in any such order or directive, direct the manner and means by which the Concessionaire performs a University Directive, and (4) no such order or directive may in any event order or direct the Concessionaire to do any act that (x) is not technically feasible or could reasonably be expected to violate any applicable Law, contravene any Consent or Authorization issued by a Governmental Authority, cause a material insured risk to become uninsurable or cause the Concessionaire to fail to be in compliance with this Agreement or (y) without the consent of the Concessionaire, result in additional expenditure by the Concessionaire of an amount in excess of \$50,000,000 in any given Fiscal Year or in excess of \$100,000,000 over any given period of five Fiscal Years (in each case Adjusted for Inflation) [starting from the Year in which the Closing occurred](#)⁷.

“University Liaison” means University Director of Utilities and Engineering Services, or such other Person as may be identified by the University to the Concessionaire in writing.

“University Required Coverages” has the meaning ascribed thereto in [Section 13.2](#).

“University Responsible Parties” has the meaning ascribed thereto in [Section 12.2](#).

“University Retained Casualty” means a casualty affecting [Uninsured Utility System Property and which is not otherwise a Concessionaire Retained Casualty](#).

“University Retained Risk Annual Payment” [has the meaning ascribed thereto in Section 13.3\(u\)](#).

“University Utility System Employees” means those Persons employed by the University immediately prior to the Closing whose duties directly relate to the operation or maintenance of the Utility System.

⁷ [NTD: This global change is necessary so that the inflation adjustment is not delayed.](#)

“University’s Option” has the meaning ascribed thereto in Section 19.7(a).

“Unplanned Outage” has the meaning ascribed thereto in Schedule 2.

“Unrecovered Balance” has the meaning ascribed thereto in Schedule 5.

“URRAP Floor” has the meaning ascribed thereto in Section 13.3(u).

“URRAP Rate” has the meaning ascribed thereto in Section 13.3(u).

“Utility” means any of the following specific individual utility services: (i) electricity, (ii) steam and condensate, (iii) domestic water, (iv) chilled water, (v) sanitary sewage, (vi) storm water, (vii) compressed air and (viii) reclaimed water, and “Utilities” means each of them.

“Utility Facilities” means the improvements and equipment (a) constituting part of or located on the University Campus, including those identified in Schedule 3, that are directly and exclusively involved in the generation, distribution and return of the Utilities and the operation and maintenance of the Utility System and that are not beyond the line of demarcation for each Utility as set forth in the Performance Standards, including the (1) distribution pipes carrying the Utilities (including pipes conveying sanitary sewage and storm water), (2) trench-boxes and vaults exclusively used in connection with the Utilities, (3) Energy Plant, (4) McClure Hall Space, (5) Chilled Water Tank (Thermal Energy Storage), (6) South Campus Chiller Plant, (7) Chip Storage/Drying Facility, (8) Transformer Storage Space, (9) Chip Facility Scale House, (10) Reclaimed Water Chlorination Building, (11) Facilities Equipment Storage, (12) Vehicle Research Lab Space, (13) Pump House 3, (14) Pump House 4, (15) Pump House 9, (16) Golf Course Water Tank, (17) I Water Tank, (18) West Lagoon, (19) Arboretum Well and (20) electric distribution wires or (b) located on Utility System Land; provided that the definition of “Utility Facilities” does not include (i) any improvements or equipment that are beyond the line of demarcation for each Utility as set forth in the Performance Standards, except for those areas (I) expressly set forth in the Performance Standards as being within said line of demarcation or (II) which the University directs to be part of the Utility System as part of a University Directive in accordance with the definition thereof or (ii) any cameras or other public safety equipment installed, maintained or used by the University Office of Public Safety and Security or any successor department.

“Utility Fee” means the fee established as compensation for the Utility Services, as set forth on Schedule 5 and as may be adjusted pursuant to the terms of this Agreement.

“Utility Services” means the services to be provided by the Concessionaire as grantee of the concession under this Agreement.

“Utility System” means (A) the personal property, real property, improvements, fixtures and equipment owned and operated by the University immediately⁸ prior to the Time of Closing to provide the Utilities on the University Campus, specifically limited to (i) the Utility System Assets, (ii) the computer systems and software set forth on Schedule 12, (iii) the Utility

⁸ NTD: This change is necessary to avoid unintentionally pulling in all such property that was used at anytime prior to Closing which was not being so used before the hand over.

Facilities, (iv) the Utility System Land, and (v) the Tunnels; provided, however, that the “Utility System” shall not include, other than expressly referred to above, (x) any utility distribution facilities or other equipment that is beyond the line of demarcation for each Utility, as set forth in the Performance Standards, except to the extent incorporated into the Utility System by a University Directive, (y) any interest in the Public Way or similar real property or (z) any utility facilities in a building that is not a building leased by the Concessionaire, up to the Utility System line of demarcation for such building, as described in the Performance Standards, except to the extent incorporated into the Utility System by a University Directive; and (B) from and after the Time of Closing, such Utility System as it is reconfigured, replaced, improved or relocated by the Concessionaire or the Operator pursuant to the terms of this Agreement.

“Utility System Assets” means (i) as of the time immediately prior to the Time of Closing, the personal property of the University used in connection with operations of the Utility System and identified on Part 3 of Schedule 3 as “Personal Property” and (ii) from and after the Time of Closing, the personal property of the Concessionaire or the Operator used in connection with the operations of the Utility System.

“Utility System Concession Value” means, at any given date, the fair market value of the Concessionaire Interest at the time of the occurrence of the relevant Adverse Action or University Default or any event of termination, cancellation, rescinding or voiding referred to in Section 16.4 (but excluding the effect of such Adverse Action, University Default or event described in Section 16.4), as determined pursuant to a written appraisal prepared in conformity with the Uniform Standards of Professional Appraisal Practice as set forth by the Appraisal Standards Board, or its successor organization, by an independent third party appraiser that is nationally recognized in appraising similar assets and that is acceptable to the University and the Concessionaire; provided, however, that the Utility System Concession Value shall in no event be less than the amount of all Leasehold Mortgage Debt (including Breakage Costs) on the End Date. If the Parties fail to agree upon such a single appraiser within 30 Days after a Party requests the appointment thereof, then the University and the Concessionaire shall each appoint an independent third party appraiser and both such appraisers shall be instructed jointly to select a third independent third party appraiser to make the appraisal referred to above. The University shall pay the reasonable costs and expenses of any appraisal.

“Utility System Land” means those parcels of real property described in Schedule 3 for the (1) Energy Plant, (2) Chilled Water Tank (Thermal Energy Storage), (3) South Campus Chiller Plant, (4) Chip Storage/Drying Facility, (5) Chip Facility Scale House, (6) Reclaimed Water Chlorination Building, (7) Facilities Equipment Storage, (8) Pump House 3, (9) Pump House 4, (10) Pump House 9, (11) Golf Course Water Tank, (12) I Water Tank, (13) West Lagoon and (14) Arboretum Well and certain other land as identified on Schedule 3 and further described in the Memorandum of Lease.

“Utility System Operations” means the operation, management and maintenance of the Utility System and all other actions relating to the Utility System that are performed by or on behalf of the Concessionaire pursuant to this Agreement.

“Utility System Purposes” means the use of the Utility System to provide Utility Services in support of the University by providing utility services to University facilities on the

University Campus, including to students, faculty, administrators, employees and invitees of the University thereon and others providing services to the University.

“Valuation Amount of Applicable Utility System Property” means the value of the applicable portion of the Utility System, as determined by State Risk, including in connection with the construction of Capital Improvements or the addition to or removal from the Utility System of buildings and/or other improvements.

“Variable Fee Component” has the meaning ascribed thereto in Schedule 5.

“Vehicle Research Lab Space” means the portion of the building identified as building #403 on Part 1 of Schedule 3 and associated improvements installed therein which portion is more particularly identified on Part 2 of Schedule 3.

“Warranty Period Utility System Projects”⁹ means those projects with respect to the Utility System completed by the University prior to the Time of Closing that ~~remain~~remained subject to an ongoing warranty from the contractor responsible for completing such projects and are listed on Schedule 23, ~~provided that the University may, if any such warranties expire prior to the Time of Closing, provide the Concessionaire notice thereof and amend Schedule 23 accordingly.~~

“Wells Fargo” has the meaning ascribed thereto in Section 9.1(j).

“West Lagoon” means the parcel identified on Part 1 of Schedule 3 as the “West Lagoon” adjacent to building #771 and associated improvements installed therein.

“Year” means the calendar year.

Section 1.2. Number and Gender. In this Agreement, words in the singular include the plural and vice versa and words in one gender include all genders.

Section 1.3. Headings. The division of this Agreement into articles, sections and other subdivisions is for convenience of reference only and shall not affect the construction or interpretation of this Agreement. The headings in this Agreement are not intended to be full or precise descriptions of the text to which they refer and shall not be considered part of this Agreement.

Section 1.4. References to this Agreement~~Section 1.4. References to this Agreement.~~ The words “herein”, “hereby”, “hereof”, “hereto” and “hereunder” and words of similar import refer to this Agreement as a whole, including the Schedules, and not to any particular portion of it. The words “Article”, “Section”, “paragraph”, “sentence”, “clause” and “Schedule” mean and refer to the specified article, section, paragraph, sentence, clause or schedule of or to this Agreement.

⁹ NTD: Changes to this definition are necessary to reflect the update that the University provided prior to Closing.

Section 1.5. References to Any Person. A reference in this Agreement to any Person at any time refers to such Person's permitted successors and assignees.

Section 1.6. Meaning of Including. In this Agreement, the words "include", "includes" or "including" mean "include without limitation", "includes without limitation" and "including without limitation", respectively, and the words following "include", "includes" or "including" shall not be considered to set forth an exhaustive list.

Section 1.7. Meaning of Discretion. In this Agreement, unless otherwise modified, the word "discretion" with respect to any Person means the sole and absolute discretion of such Person.

Section 1.8. Meaning of Notice. In this Agreement, the word "notice" means "written notice", unless specified otherwise.

Section 1.9. Consents and Approvals. Unless specified otherwise, wherever the provisions of this Agreement require or provide for or permit an approval or consent by either Party, such approval or consent, and any request therefor, must be in writing (unless waived in writing by the other Party).

Section 1.10. Trade Meanings. Unless otherwise defined herein, words or abbreviations that have well-known trade meanings are used herein in accordance with those meanings.

Section 1.11. Laws. Unless specified otherwise, references to a Law are considered to be a reference to (i) such Law as it may be amended from time to time, (ii) all regulations and rules pertaining to or promulgated pursuant to such Law, (iii) the successor to the Law resulting from recodification or similar reorganizing of Laws and (iv) all future Laws pertaining to the same or similar subject matter.

Section 1.12. Currency. Unless specified otherwise, all statements of or references to dollar amounts or money in this Agreement are to the lawful currency of the United States of America.

Section 1.13. Generally Accepted Accounting Principles. All accounting and financial terms used herein, unless specifically provided to the contrary, shall be interpreted and applied in accordance with GAAP.

Section 1.14. Calculation of Time. For purposes of this Agreement, a period of Days shall be deemed to begin on the first Day after the event that began the period and to end at 5:00 p.m., which time shall be determined by the time in the City of Moscow, Idaho on the last Day of the period. If, however, the last Day of the period does not fall on a Business Day, the period shall be deemed to end at 5:00 p.m., which time shall be determined by the time in the City of Moscow, Idaho on the next Business Day.

Section 1.15. Approvals, Consents and Performance by the University.

- (a) *Procedures.* Wherever the provisions of this Agreement require or provide for or permit an approval or consent by the University of or to any action, Person, Document, or other matter contemplated by this Agreement, the following provisions shall apply: (i) such request for approval or consent must (1) contain or be accompanied by any documentation or information required for such approval or consent in reasonably sufficient detail, as reasonably determined by the University, (2) clearly set forth the matter in respect of which such approval or consent is being sought, (3) form the sole subject matter of the correspondence containing such request for approval or consent, and (4) state clearly that such approval or consent is being sought; (ii) such approval or consent shall not be unreasonably withheld, conditioned or delayed (unless such provision provides that such approval or consent may be unreasonably withheld, conditioned or delayed or is subject to the discretion of the University); (iii) the University shall advise the Concessionaire by written notice either that it consents or approves or that it withholds its consent or approval, in which latter case it shall set forth, in reasonable detail, its reasons for withholding its consent or approval, which reasons may include the insufficiency, as determined by the University acting reasonably, of the information or documentation provided; (iv) unless a time period is specifically set forth elsewhere herein, the University shall, within 30 Days after receipt of the Concessionaire's request, (1) provide the responding notice mentioned in clause (iii) of this Section 1.15(a) or (2) if the University determines in its discretion that additional time to consider such request would be appropriate due to the request's complexity or interrelationship with larger University issues, advise the Concessionaire by written notice of a reasonable timeframe (not to exceed 120 Days) in which the University will provide the responding notice mentioned in clause (iii) of this Section 1.15(a), which written notice shall extend the timeframe for Approval of the request to the timeframe set forth in such notice; (v) if the responding notice mentioned in clause (iii) of this Section 1.15(a) indicates that the University does not approve or consent, the Concessionaire may take whatever steps may be necessary to satisfy the objections of the University set out in the responding notice and, thereupon, may resubmit such request for approval or consent from time to time and the provisions of this Section 1.15 shall again apply; (vi) if the disapproval or withholding of consent mentioned in clause (iii) of this Section 1.15(a) is subsequently determined pursuant to Article 18 to have been improperly withheld or conditioned by the University, such approval or consent shall be deemed to have been given on the date by which such approval or consent should have been provided; provided that, to the extent any deadlines for performing work are determined by reference to the date of consent or approval, such consent or approval shall be deemed to have been given on the date of determination rather than the date such consent or approval should have been provided; and (vii) for the avoidance of doubt, any dispute as to whether or not a consent or approval has been unreasonably withheld, conditioned or delayed shall be resolved in accordance with the provisions of Article 18. The Concessionaire shall submit any request for approval or consent to the

University Liaison, who will direct such request to the appropriate committee, Person or group within the University.

- (b) *Approved Documents.* Subject to the other provisions hereof, wherever in this Agreement an approval or consent by the University is required with respect to any document, proposal, certificate, plan, drawing, specification, contract, agreement, budget, schedule, report or other written instrument whatsoever (a “Document”), following such Approval such Document shall not be amended, supplemented, replaced, revised, modified, altered or changed in any manner whatsoever without obtaining a further Approval in accordance with the provisions of this Section 1.15.

Section 1.16. Incorporation of Schedules. The Schedules are integral to, and are made a part of, this Agreement. In the event of any conflict between the terms of this Agreement and the terms of the Schedules, the terms of this Agreement shall control.

Section 1.17. References to Agreements Generally. References to agreements (including this Agreement) and other contractual instruments shall be deemed to include all amendments, restatements, extensions and other modifications to such instruments, whether in effect as of the Effective Signing Date¹⁰ or made thereafter.

Section 1.18. Cost Responsibilities. In this Agreement, the phrases “at Concessionaire’s sole cost and expense”, “at Concessionaire’s cost and expense”, “the Concessionaire shall be responsible for providing”, “the Concessionaire shall pay”, “the Concessionaire shall reimburse” and similar phrases and provisions that require the Concessionaire to take certain actions or perform certain services, shall not mean that such costs or expenses, or the costs and expenses associated with such actions or activities, are necessarily subject to recovery as part of the Utility Fee or otherwise in accordance with this Agreement. The inclusion of such costs and expenses in the Utility Fee shall be determined in accordance with Schedule 5.

Section 1.19. Out-of-Pocket Costs. In this Agreement, any reference to “out-of-pocket” or “out of pocket” costs or expenses of the Concessionaire or Operator and similar phrases and provisions shall mean the reasonable, incremental actual costs paid by the Concessionaire or Operator to a third party that (i) is not an Affiliate of the Concessionaire, the Operator or any Equity Participant or (ii) is an Affiliate of the Concessionaire, the Operator or any Equity Participant, provided that the payments to such Affiliate are on arms’ length terms consistent with those terms offered by unaffiliated third parties for similar goods or services.

Section 1.20. Amendment and Restatement. This Agreement shall amend and restate, in its entirety, the Original Agreement. From and after the date hereof, this Agreement shall be the operative agreement, and the Original Agreement shall be of no force or effect.

¹⁰ NTD: This change is necessary because “Effective Date” is not defined.

ARTICLE 2

THE TRANSACTION; CLOSING; CONDITIONS PRECEDENT; COVENANTS

Section 2.1. Grant of Concession. Upon the terms and subject to the conditions of this Agreement, effective at the Time of Closing, (a) the Concessionaire shall pay the University the exact amount of \$225,000,000 in cash (the “Closing Consideration”) in accordance with Section 2.2(a), (b) the University (i) demises and leases the Utility System Land and the Utility Facilities and (ii) grants the Concessionaire a license to access and use the Tunnels in accordance with Section 3.22 in order to perform its obligations under this Agreement with respect thereto, in each case to the Concessionaire free and clear of Encumbrances other than Permitted University Encumbrances and on an exclusive basis, other than as expressly provided in this Agreement, for and during the term (the “Term”) commencing on the Closing Date and expiring on the 50th anniversary of the Closing Date (or such later date as may be required to effect a Delay Event Remedy but subject to earlier termination as provided in this Agreement), provided that such demise and lease of the Utility Facilities other than those located on the Utility System Land and the license to access the Tunnels shall not prevent the University from using, occupying, developing, leasing or otherwise enjoying the real property and the improvements other than the land on which the Utility Facilities are located or adjacent, over or under which the Tunnels are located without the payment of any fee, charge or rent to the Concessionaire, and (c) the University (i) grants the Concessionaire a non-exclusive license during the Term, appurtenant to the leasehold interest described in clause (b)(i) above, to access the Public Way and other portions of the University Campus (subject to Section 3.2(b)), solely in order to operate, maintain, repair, replace, improve and service the Utility Facilities located therein or thereon to the extent permitted or required under this Agreement, (ii) grants the Concessionaire, free and clear of any Encumbrances (other than Permitted University Encumbrances) an exclusive right for and during the Term to operate the Utility System (and any expansions, improvements or replacements thereto) and to provide Utility Services on the University Campus (except as expressly provided herein), and in connection therewith (A) to use, possess, control, operate, manage, modify, maintain and rehabilitate the Utility System; and (B) to charge the Utility Fee; and ~~(iv) assign, transfer~~ (iii) assigns, transfers and otherwise ~~convey~~ conveys to the Concessionaire by bill of sale each of the Utility System Assets identified on Schedule 3, free and clear of any Encumbrances (other than Permitted University Encumbrances) and the Concessionaire ~~hereby accepts~~ thereby accepted each such demise, lease, license, grant, assignment, transfer and conveyance (collectively, the “Transaction”). The Parties acknowledge the Transaction closed on the Time of Closing and the foregoing were all effective as of that time.¹¹

Section 2.2. Closing.

- (a) The closing of the Transaction (the “Closing”) shall take place on the date that is on or before 65 Days after the date hereof, but in no event sooner than 45 Days after the date hereof, of which date the Concessionaire shall provide written notice to the University at least 20 Business Days prior thereto, or such other date as agreed in writing by the Concessionaire and the University (the “Closing

¹¹ NTD: This change is necessary to document that the University is not again assigning the assets and that the Closing did occur.

Date”). If, after execution, the Concessionaire requests that the Closing Date take place earlier than 60 days after the date hereof, the University shall consider such request in good faith but shall not be obligated to agree to such request. The Closing shall be held at the University of Idaho, Division of Finance and Administration, 875 Perimeter Drive, Moscow ID 83844-3168 or such other place agreed to in writing by the University and the Concessionaire. At the Time of Closing, the Concessionaire shall deliver or cause to be delivered to the University same-day funds by wire transfer in the amount of the Closing Consideration (plus or minus, as appropriate, any adjustment in accordance with Section 2.2(b), and upon receipt of such payment the Transaction shall be effective. The Concessionaire shall wire the Closing Consideration to bank account(s) and/or payees and in increments designated by the University. Upon receipt of the funds described in the preceding sentences in this Section 2.2(a), the University shall immediately cancel and return the Closing Deposit and the Cash Deposit (unless such Closing Deposit or Cash Deposit is applied against the Closing Consideration by the University in accordance with Section 2.3(c)), in accordance with the Concessionaire’s instructions. The Parties acknowledge the Closing occurred on the Time of Closing and the foregoing were all effective as of that time.

- (b) All Prorated Items shall be prorated between the University and the Concessionaire as of 11:59 p.m. on the Day immediately preceding the Closing Date based upon the actual number of Days in the month and a 365-Day year and the required payment resulting from such proration shall be added to or subtracted from the Closing Consideration as follows:
- (i) At least 5 Days prior to the Closing, the University will provide to the Concessionaire an itemized statement of such Prorated Items, estimated in good faith as of the Closing and reasonably based on relevant billing information from third parties or (in the absence of such information) the University’s financial statements as of June 30, 2020, and such statement shall be the basis of proration of any Prorated Items at the Closing and any resulting adjustment to the Closing Consideration in accordance with this Section 2.2(b);
 - (ii) Within 45 Business Days after the Closing, the University will provide to the Concessionaire a revised good-faith accounting of such Prorated Items as of the Closing in the form of an itemized statement of such Prorated Items (the “Revised Proration Statement”);
 - (iii) Within 15 Business Days after the Concessionaire’s receipt of the Revised Proration Statement, the Concessionaire will review the Revised Proration Statement and will notify the University of any adjustments made by the Concessionaire to the Revised Proration Statement in good faith;
 - (iv) To the extent the University disagrees with any of the Concessionaire’s adjustments to the Revised Proration Statement, the University shall

provide notice to the Concessionaire within 15 Business Days after the University's receipt of the Concessionaire's adjustments, and any disagreement shall be resolved in accordance with Article 18; and

- (v) Upon final resolution with respect to the proration of each such Prorated Item (whether by agreement of the Parties or in accordance with Article 18), the Party that is determined to owe money pursuant to the proration of that Prorated Item shall pay to the other party the amount owed within 10 Business Days of such determination.

Section 2.3. Deposit.

- (a) The University acknowledges receipt from the Concessionaire of cash (the "Cash Deposit") and/or one or more Letters of Credit with a term of at least 120 Days from the ~~date hereof~~ Signing Date (the "Closing Deposit"), in an aggregate amount equal to \$10,000,000, to be held by the University for the sole purpose described in Section 2.3(b). The University shall deposit any Cash Deposit with the Escrow Agent, which shall invest such amount in Eligible Investments pending the Closing. The Parties acknowledge that the University returned the Closing Deposit promptly after the Closing.
- (b) If the University terminates this Agreement pursuant to Section 2.4(d)(iv) (including as a result of the failure of the Concessionaire to pay the Closing Consideration at the Closing in accordance with the terms hereof so long as said failure to deliver funds is not the direct result of the University's actions or omissions), then the University shall be entitled to (i) retain the Cash Deposit and all interest accrued thereon and, (ii) without notice to the Concessionaire, immediately draw the full amount of the Closing Deposit upon presentation of a sight draft and a certificate confirming that the University has the right to draw under the Closing Deposit in the amount of such sight draft, and the University shall be entitled to retain the Cash Deposit and all of the proceeds of the Closing Deposit, in each case as the sole remedy or right of the University against the Concessionaire hereunder (provided that this limitation shall not apply in the event of fraud or intentional misrepresentation of the Concessionaire); provided, however, that if this Agreement is terminated for any other reason prior to Closing, the University shall return any Cash Deposit and the interest earned thereon in accordance with the Concessionaire's reasonable instructions, and deliver, in accordance with the Concessionaire's reasonable instructions, the Closing Deposit and agree to cancel the Closing Deposit, in each case, immediately following any such termination. The Concessionaire acknowledges that the loss the University will incur in the event of a termination under Section 2.4(d)(iv) is difficult to ascertain, and that the University's right to retain the Cash Deposit and to draw the Closing Deposit as set forth above is based on the Parties' reasonable estimate, taking into account the magnitude of the Transaction and the other relevant considerations, as to such loss and is not intended as, and does not constitute, a penalty. Except in cases involving fraud or intentional misrepresentation by the Concessionaire, the right of the

University to retain the Cash Deposit or to draw the Closing Deposit is intended to be, and shall constitute, liquidated damages, and any payment thereof to the University shall terminate the University's rights and remedies in all respects.

- (c) At the Closing, upon the satisfaction of the conditions set forth in Section 2.4(a), Section 2.4(b) and Section 2.4(c), the Concessionaire shall be entitled to, as applicable, (i) with respect to the Cash Deposit, (1) a full return of the Cash Deposit, if any, and all investment earnings accrued thereupon or (2) apply the Cash Deposit (including any accrued interest) as a credit against the Closing Consideration and (ii) with respect to the Closing Deposit, (1) a return of the Closing Deposit, (2) its cancellation or (3) its application as a credit against the Closing Consideration, in any case as directed by the Concessionaire prior to Closing.

Section 2.4. Conditions Precedent; Termination.

- (a) *Conditions for the Benefit of the Concessionaire.* The Concessionaire ~~shall be~~ was obligated to complete the Closing only if each of the following conditions ~~has~~ had been satisfied in full at or before the Time of Closing, unless waived by the Concessionaire, which the Concessionaire acknowledges were satisfied at or before the Time of Closing such that Closing occurred:¹²
- (i) the representations and warranties of the University set forth in Section 9.1 shall be true and correct in all material respects on and as of the ~~date hereof~~ Signing Date and at and as of the Time of Closing with the same force and effect as if made at and as of such time and date except that (A) representations and warranties that by their terms speak only as of the ~~date hereof~~ Signing Date or some other date need to be true and correct only as of such date and (B) those representations and warranties which are subject to a materiality or a Material Adverse Effect qualifier in Section 9.1 shall be true and correct in all respects on and as of the ~~date hereof~~ Signing Date and at and as of the Time of Closing with the same force and effect as if made at and as of such time and date;
- (ii) the University shall not be in material breach of any material covenant on its part contained in this Agreement which is to be performed or complied with by the University at or prior to the Time of Closing;
- (iii) the University shall have obtained and delivered to the Concessionaire, at the expense of the Concessionaire, a commitment effective at the Time of Closing for a leasehold title policy or policies, in form and substance reasonably acceptable to the Concessionaire (which will include an endorsement with the terms of the leasehold coverage), proposing to insure the leasehold interest of the Concessionaire in the Utility System Land, to the extent of such leasehold interest, subject only to

¹² NTD: This change is necessary to document that no closing conditions were unsatisfied.

(A) Permitted University Encumbrances, (B) Permitted Concessionaire Encumbrances (other than the Permitted Concessionaire Encumbrances specified in clause (iv), clause (vii) and clause (ix) of the definition of “Permitted Concessionaire Encumbrances” as it pertains to clause (iii) of this Section 2.4(a)) and (C) any Encumbrances the Concessionaire is required to remove pursuant to Section 3.5(a) (the “Title Commitment”) from the Title Company, from which Title Company the Concessionaire shall purchase any leasehold title insurance policies (or any other title policies related to the Transaction) that it elects to purchase at Concessionaire’s cost in connection with the Transaction or any Leasehold Mortgage;

- (iv) the University shall have delivered to the Concessionaire a legal opinion from the Office of the General Counsel of the University, in substantially the form attached hereto as Schedule 7, which legal opinion shall, if requested by the Concessionaire in writing prior to the Closing, also be addressed to any Leasehold Mortgagee providing Leasehold Mortgage Debt at the Time of Closing (and shall cover, as applicable, any consent to assignment or direct agreement with respect to the Leasehold Mortgage Debt that the University executes with such Leasehold Mortgagee);
- (v) the University shall have executed and delivered to the Concessionaire (A) the assignments, transfers and conveyances contemplated by Section 2.1, and (B) the consents and estoppel certificates contemplated by Section 10.2 and the consent agreement contemplated by Section 19.1(i);
- (vi) there shall not have occurred a material casualty loss, destruction or damage to, or condemnation of, the Utility System; provided, however, that as used in this Section 2.4(a)(vi), a material casualty loss, destruction or damage to, or condemnation of, the Utility System means the casualty, loss, damage, destruction or condemnation of the Utility System such that its annualized aggregated delivery capacity (calculated in British Thermal Units) for the electricity, steam, domestic water and chilled water portions of the Utility System has been reduced by at least 10% since the Setting Date;
- (vii) from the Setting Date through and including the Time of Closing, no action or event has transpired that would have constituted an Adverse Action had it occurred during the Term;
- (viii) all Campus-Wide Permits set forth on Schedule 18 are in full force and effect;
- (ix) no Tax-Advantaged Bonds of the University that (i) are encumbered by, or are otherwise secured by, the revenues or other assets of any portion of the Utility System, or (ii) would lose their status as Tax-Advantage Bonds

upon consummation of the Transaction shall be outstanding as of the Closing Date, and the University shall provide an opinion of bond counsel confirming that no such Tax-Advantaged Bonds are outstanding together with a certificate granting the Concessionaire and the collateral agent the right to rely on such opinion; and

- (x) the University shall have delivered to the Concessionaire a certificate confirming that each of the conditions set forth in Section 2.4(a)(i) through Section 2.4(a)(x) has been satisfied in full by the University (except for any condition that has been waived by the Concessionaire) at or before the Time of Closing.
- (b) *Conditions for the Benefit of the University.* The University ~~shall be~~was obligated to complete the Closing only if each of the following conditions precedent ~~has~~had been satisfied in full at or before the Time of Closing, unless waived by the University, which the University acknowledges were satisfied at or before the Time of Closing such that Closing occurred:
- (i) the representations and warranties of the Concessionaire set forth in Section 9.2 shall be true and correct in all material respects on and as of the ~~date hereof~~Signing Date and at and as of the Time of Closing with the same force and effect as if made at and as of such time and date except that (A) representations and warranties that by their terms speak only as of the ~~date hereof~~Signing Date or some other date need to be true and correct only as of such date and (B) those representations and warranties which are subject to a materiality or a Material Adverse Effect qualifier in Section 9.2 shall be true and correct in all respects on and as of the ~~date hereof~~Signing Date and at and as of the Time of Closing with the same force and effect as if made at and as of such time and date;
- (ii) the Concessionaire shall not be in material breach of any material covenant on its part contained in this Agreement which is to be performed or complied with by the Concessionaire at or prior to the Time of Closing (including the obligation of the Concessionaire to pay the Closing Consideration at the Closing in accordance with the terms hereof);
- (iii) the Concessionaire shall have delivered to the University a legal opinion of outside counsel to the Concessionaire, substantially in the form attached hereto as Schedule 8;
- (iv) all Leasehold Mortgage Debt issued by the Concessionaire on or before Closing shall have a credit rating of at least investment grade as determined by at least one of the Credit Rating Agencies and the Concessionaire shall have delivered to the University a certificate describing the material terms of such Leasehold Mortgage Debt, except that some (but not all) of such Leasehold Mortgage Debt issued on or before Closing need not have a credit rating of at least investment grade as

determined by at least one of the Credit Rating Agencies if such Leasehold Mortgage Debt is, within 6 months after Closing, either (i) completely repaid and retired or (ii) given a credit rating of at least investment grade as determined by at least one of the Credit Rating Agencies and, in either case, the Concessionaire has provided the University with Notice and reasonable proof thereof; provided, however, if such indebtedness is not retired or given the required credit rating within such 6-month period, it shall be deemed a Concessionaire Default and such indebtedness will not be "Leasehold Mortgage Debt" thereafter for purposes of this Agreement; ~~and~~

- (v) the Concessionaire shall have delivered to the University a certificate confirming that the Operator has engaged McKinstry Essention, LLC ("McKinstry") or a special purpose entity owned by McKinstry on a long-term basis to serve as a Contractor to the Operator to perform substantially all of the daily operations and maintenance with respect to the Utility System for which the Concessionaire is responsible hereunder; and
 - (vi) the Concessionaire shall have delivered to the University a certificate confirming that each of the conditions set forth in Section 2.4(b)(i) through Section 2.4(b)(v) has been satisfied in full by the Concessionaire (except for any condition that has been waived by the University) at or before the Time of Closing.
- (c) *Mutual Conditions.* In addition, the University and the Concessionaire shall be obligated to complete the Closing only if each of the following conditions precedent has been satisfied in full at or before the Time of Closing, unless waived by both the University and the Concessionaire, which the Parties acknowledge were satisfied at or before the Time of Closing:
- (i) there shall be no preliminary or permanent injunction or temporary restraining order or other order issued by a Governmental Authority of competent jurisdiction or other legal restraint or prohibition enjoining or preventing the consummation of the Transaction; and
 - (ii) there shall be no action taken, or any Law enacted, entered, enforced or deemed applicable to the Transaction by any Governmental Authority of competent jurisdiction that, in any such case, has resulted or (in the case of any pending review or proceeding, if adversely determined) could reasonably be expected to result in such Governmental Authority conditioning or restricting the consummation of the Transaction in a manner that would impose a material impairment on the Transaction or make the consummation of the Transaction illegal.

- (d) *Termination.* This Agreement may be terminated at any time prior to the Closing:
- (i) by mutual consent of the University and the Concessionaire in a written instrument;
 - (ii) by either the University or the Concessionaire, upon notice to the other Party, if any Governmental Authority of competent jurisdiction shall have issued an order, decree or ruling or taken any other action permanently restraining, enjoining or otherwise prohibiting the Transaction, and such order, decree, ruling or other action has become final and nonappealable; provided, however, that the right to terminate this Agreement under this Section 2.4(d)(ii) shall not be available to any Party whose failure to comply with any provision of this Agreement or other conduct has been the direct cause of, or directly results in such action;
 - (iii) by the Concessionaire, upon written notice to the University, if any condition set forth in Section 2.4(a) is not satisfied at the Time of Closing; provided, however, that the Concessionaire shall not have the right to terminate this Agreement under this Section 2.4(d)(iii) if (A) the Concessionaire shall have theretofore waived such condition, (B) the Concessionaire's failure to comply with any provision of this Agreement or other conduct has been the cause of, or resulted in, the failure of such condition or conditions to be satisfied or (C) any condition set forth in Section 2.4(b) is not satisfied at the Time of Closing;
 - (iv) by the University, upon written notice to the Concessionaire, if any condition set forth in Section 2.4(b) is not satisfied at the Time of Closing; provided, however, that the University shall not have the right to terminate this Agreement under this Section 2.4(d)(iv) if (A) the University shall have theretofore waived such condition, (B) the University's failure to comply with any provision of this Agreement or other conduct has been the cause of, or resulted in, the failure of such condition or conditions to be satisfied or (C) any condition set forth in Section 2.4(a) is not satisfied at the Time of Closing; or
 - (v) by either the University or the Concessionaire upon notice to the other Party if the Closing has not occurred within 20 Business Days after the Closing Date or such later date agreed to in writing by the Parties, provided that if the Closing has not occurred due to a Party's failure to satisfy the conditions precedent for the Closing for which such Party is responsible pursuant to this Section 2.4, that Party may not terminate this Agreement pursuant to this Section 2.4(d)(v).
- (e) *Effect of Termination.* In the event of termination of this Agreement by either the University or the Concessionaire as provided in Section 2.4(d), this Agreement shall forthwith become void and there shall be no liability or

obligation on the part of the University or the Concessionaire or their respective Representatives, except as set forth in Section 2.3(b), this Section 2.4(e), Article 12, Article 18 and Article 19. In the event that the Concessionaire terminates this Agreement pursuant to Section 2.4(d)(iii) as a result of the failure of the University to satisfy any condition set forth in Section 2.4(a) (excluding Section 2.4(a)(vi) and Section 2.4(a)(vii), but, with respect to the exclusion of Section 2.4(a)(vii), only to the extent the event described in Section 2.4(a)(vii) was not an action taken by the University), the University will compensate the Concessionaire in the aggregate amount of up to \$1,500,000 for (i) reasonable and documented out-of-pocket costs and (ii) reasonable internal costs (calculated based on the market rate for such costs) incurred by the Concessionaire or the Operator in connection with the Transaction. In the event of any termination pursuant to Section 2.4(d)(i), Section 2.4(d)(ii), Section 2.4(d)(iii) or Section 2.4(d)(v), the Cash Deposit and all investment earnings accrued thereon shall be paid to the Concessionaire, and the Closing Deposit shall be returned undrawn to the Concessionaire marked canceled, as applicable.

(f) [Acknowledgement. The Parties acknowledge that the Original Agreement was not terminated pursuant to Section 2.4\(d\) thereof, and Sections 2.4\(d\) and \(e\) of this Agreement shall be of no force or effect as a result thereof.](#)¹³

Section 2.5. Covenants.

- (a) *Cooperation.* During the Closing Period, the Parties shall cooperate with each other in order to permit the Closing to be consummated on the Closing Date.
- (b) *Reasonable Efforts.* During the Closing Period, each Party shall use all reasonable efforts (i) to take, or cause to be taken, all actions necessary to comply promptly with all requirements under this Agreement and all legal requirements which may be imposed on such Party to consummate the Transaction as promptly as practicable, including making any necessary filings, and (ii) to obtain (and to cooperate with the other Party to obtain) any Consent of any Governmental Authority or any other public or private third party which is required to be obtained or made by such Party in connection with the consummation of the Transaction. Each Party shall promptly cooperate with and promptly furnish information to the other Party at such other Party's reasonable request in connection with any such efforts by, or requirement imposed upon, any of them in connection with the foregoing.
- (c) *Injunctions.* If any Governmental Authority of competent jurisdiction issues a preliminary or permanent injunction or temporary restraining order or other order before the Time of Closing which would prohibit or materially restrict or hinder the Closing, each Party shall use all reasonable efforts to have such injunction, decree or order dissolved or otherwise eliminated or to eliminate the

¹³ [NTD: This change is necessary to document the closing.](#)

condition that formed the basis for such injunction or order, in each case as promptly as possible and, in any event, prior to the Time of Closing.

- (d) *Operation of the Utility System.* During the Closing Period, the University shall operate the Utility System in the ordinary course in a manner consistent with past practice, which shall include using all reasonable efforts to preserve the goodwill of the Utility System and to maintain good business relationships with Persons having business dealings with respect to the Utility System, to maintain the Utility System in its existing operating condition and repair in accordance with past practice (ordinary wear and tear excepted), not to incur any Encumbrances on the Utility System (other than Permitted University Encumbrances) that are not satisfied by the Closing Date, and to cause the Utility System to be operated in all material respects in accordance with all applicable Laws (except to the extent any non-compliance is being contested in good faith by appropriate proceedings), all to the end that the Utility System as a going concern shall be unimpaired and delivered to the Concessionaire at the Time of Closing in a condition not materially worse than the condition as of the Setting Date, except for any damage by casualty or condemnation. The University, shall, up to and including the Time of Closing, be entitled to all of the cash or cash equivalents in or generated by the Utility System. The Concessionaire acknowledges that all receivables related to the Utility System in existence at the Time of Closing shall remain the property of the University and the Concessionaire shall transfer to the University any such receivables, existing up to and including the Time of Closing, received after the Closing Date within 30 Days after the Concessionaire's receipt of such receivables. Without limiting the foregoing, the University shall not, without the Concessionaire's approval, which shall not be unreasonably withheld, conditioned or delayed, (i) terminate, amend, modify or agree to a waiver of the terms of any Authorization related to the Utility System after the ~~date hereof~~[Signing Date](#) and before the Time of Closing or (ii) commence any Material Changes or Capital Improvements to the Utility System that are not (1) Ongoing Utility System Projects or (2) reasonably necessary to address an Emergency; provided, the Capped O&M Index for the Fiscal Year in which such Capital Improvements are made shall be increased by any amounts the Concessionaire can reasonably prove caused an increase in the Capped O&M Costs as a direct result of such Capital Improvement or Material Change made to address an Emergency without the Concessionaire's approval. Notwithstanding anything to the contrary in this Agreement, the University shall, on behalf of the Concessionaire, operate and maintain the Utility System through 11:59 p.m. on the Closing Date, so as to facilitate the transition of the operation of the Utility System in a timely and orderly manner. The Concessionaire shall be fully liable under this Agreement to perform the Utility Services after the Time of Closing.
- (e) *Disclosure of Changes.*
- (i) During the Closing Period, each Party shall immediately disclose in writing to the other Party any matter which becomes known to it which is

inconsistent in any material respect with any of the representations or warranties contained in Article 9. No such disclosure, however, shall cure any misrepresentation or breach of warranty for the purposes of Section 2.4 or Article 12; and

- (ii) During the Closing Period, the University may supplement or amend the Disclosure Schedules hereto, including one or more supplements or amendments to correct any matter which would constitute a breach of any representation, warranty, covenant or obligation contained herein. No such supplement or amendment shall be deemed to cure any breach for purposes of Section 2.4(a) or, subject to the following sentence, for any other purpose. Notwithstanding the previous sentence, if the Closing occurs, then, subsequent to the Closing, any such supplement or amendment provided to the Concessionaire at least 10 Business Days prior to the Closing with respect to any representation or warranty contained in Section 9.1(d), or Section 9.1(i) relating to a matter arising after the ~~date hereof~~ Signing Date but before the Closing will be effective to cure and correct for all purposes any inaccuracy in, or breach of, such representation or warranty which would exist if the University had not made such supplement or amendment, and all references to any Disclosure Schedule hereto which is supplemented or amended as provided in this Section 2.5(e)(ii) shall (subject to the foregoing limitation) for all purposes after the Closing be deemed to be a reference to such Disclosure Schedule as so supplemented or amended. The Concessionaire acknowledges that the University supplemented and amended the Disclosure Schedules by delivery of written notice on December 9, 2020.

- (f) *Access to Information and Pre-Closing Inspections.* During the Closing Period, but subject to confidentiality obligations binding on the University with respect to any Person (provided that the University has disclosed to the Concessionaire the existence of the applicable Document that is subject to such confidentiality limitation in order to enable the Concessionaire to evaluate the materiality and significance of the lack of disclosure based on such limitations), the University shall (i) give the Concessionaire and its Representatives reasonable access during normal business hours and on reasonable notice to the Utility System to perform inspections on the Utility System, subject to the University's policies and regulations regarding safety and security and any other reasonable conditions imposed by the University, (ii) permit the Concessionaire and its Representatives to make such inspections as they may reasonably request in order to facilitate the transition of the use, operation, possession and control of the Utility System to the Concessionaire and (iii) furnish the Concessionaire and its Representatives with such financial and operating data and other information that is available with respect to the Utility System as they may from time to time reasonably request; provided that no inspections or the results thereof shall permit the Concessionaire to terminate this Agreement solely as a result thereof but shall not serve as a waiver of any of the Concessionaire's rights hereunder. The Concessionaire shall hold and shall cause its Representatives to hold in strict

confidence all Documents and information concerning the Utility System to the extent and in accordance with the terms and conditions of the confidentiality agreement between the University and the Concessionaire in connection with the Transaction. After the Closing Date, the Concessionaire shall, at the request of the University, in connection with claims or actions brought by or against third parties based upon events or circumstances concerning the Utility System, (A) provide reasonable assistance in the collection of information or Documents and (B) make the Concessionaire's employees available when reasonably requested by the University; provided, however, that the University shall reimburse the Concessionaire for all out-of-pocket and documented costs and expenses incurred by the Concessionaire in providing said assistance and will not unduly interfere with the Concessionaire's operations.

(g) *Transition.*

- (i) During the Closing Period, the Parties shall cooperate with each other to ensure the orderly transition of control, possession, custody, operation, management and maintenance of the Utility System at the Time of Closing and to provide the services required to be performed under this Agreement. Such cooperation shall include the University making its employees reasonably available to the Concessionaire to assist in such transition at no out-of-pocket cost to the University. In order to assure such orderly transition and to provide information and Documents related to the Utility System Operations to the Concessionaire, the University shall use commercially reasonable efforts to exercise its rights under existing service agreements with service providers. After the Closing, the Parties shall continue to cooperate to ensure the orderly transition of control, possession, custody, operation, management and maintenance of the Utility System, provided that no University employees shall work to operate the Utility System after the Closing, provided that the foregoing shall not modify the rights of the Parties as set forth in Section 2.5(g)(ii).
- (ii) At the request of the Concessionaire, the University will use commercially reasonable efforts to provide to the Concessionaire, for up to 12 months after the Closing Date, the services of any University Utility System Employees and other employees of the University (who for the avoidance of doubt remain employees of the University at the time of such request). The Concessionaire and the University agree that during the period of time that any services are performed by any University Utility System Employee or other employee of the University pursuant to this Section 2.5(g)(ii), the University Utility System Employees or such other employees shall continue to be employees of the University and not be employees of the Concessionaire. All such services shall be provided for an amount equal to the actual cost to the University (including employment costs and related overhead expenses allocable to such employees, as reasonably determined by the University), which amount shall be billed to the Concessionaire as soon as reasonably practicable

following the end of each month and shall be payable by the Concessionaire within 30 Days of receipt of any such statement, and upon such other reasonable terms and conditions as the University and the Concessionaire may agree; provided, however, that such statement shall show in reasonable detail the hours worked and hourly rate of each such University Utility System Employee or other employee by the University and the amount of overhead expenses allocated to each such University Utility System Employee or other employee by the University.

- (h) *Casualty Loss Prior to Closing.* If between the Setting Date and the Time of Closing, a casualty loss, destruction or damage to, or a condemnation of, the Utility System or a portion thereof has occurred, unless this Agreement has been terminated under Section 2.4(d), then the University shall, at its option, either (i) promptly and diligently repair and rebuild the affected parts of the Utility System to restore them to at least the same condition in which they were before the occurrence of such casualty loss, destruction, damage or condemnation to the extent reasonably practicable, provided that if the affected parts of the Utility System cannot prior to the Closing Date be repaired or rebuilt to restore them to at least the same condition in which they were before the occurrence of such casualty loss, destruction, damage or condemnation, the University shall make such repairs or restoration as can reasonably be completed prior to the Closing Date and shall provide to the Concessionaire a plan for the completion of such remaining repairs or restoration following the Time of Closing at the University's expense and shall then complete such repairs or restoration (to the extent reasonably practicable) in accordance with such plan, or (ii) authorize the Concessionaire to repair the Utility System and assign to the Concessionaire all insurance, condemnation and other proceeds (if any) payable by third-party insurers or other third parties in respect of such casualty loss, destruction, damage or condemnation and enforce (with the cooperation of the Concessionaire) all of its rights, remedies and privileges under any applicable insurance policies with third-party insurers, the costs of which shall not be included in the Variable Fee Component or the Utility Fee; provided that if no insurance exists or such insurance or condemnation proceeds are not sufficient to repair and rebuild the affected parts of the Utility System to its prior condition, then the University shall reimburse the Concessionaire for that amount representing the difference between the out-of-pocket cost to repair and the amount of any insurance or condemnation proceeds received by the Concessionaire. It shall not be a Concessionaire Default for the inability of the Concessionaire to meet any obligation hereunder as a direct result of such casualty loss, destruction, damage or condemnation unless the University has elected to authorize the Concessionaire to repair the Utility System pursuant to clause (ii) of this Section 2.5(h) and the Concessionaire is not diligently repairing or restoring the Utility System and any work performed by the University or by the Concessionaire after the Closing Date in order to repair or rebuild the Utility System to at least the same condition in which they were before the occurrence of such casualty loss, destruction, damage or condemnation shall constitute a Delay Event, provided if the Concessionaire is

undertaking such work, it shall do so diligently to be completed as soon as reasonably practicable. The Parties acknowledge and agree that no such casualty loss, destruction, damage or condemnation occurred during the Closing Period.

- (i) *Policies of Insurance.* During the Closing Period, the University shall continue in force all applicable policies of insurance maintained by the University in respect of the Utility System. Except to the extent the University is required to maintain such policies of insurance in accordance with Article 13, at the Time of Closing, all such policies of insurance shall terminate and the Concessionaire shall be responsible for obtaining insurance for the Utility System in accordance with the terms hereof.
- (j) *Employees.* Prior to the Time of Closing, the Concessionaire shall use its best efforts to or cause the Operator to interview all University Utility System Employees who apply for a position with the Concessionaire or the Operator, as the case may be. If either the Concessionaire or the Operator makes any offer of employment to any such individual, such offer shall contain only the terms and conditions of employment that the Concessionaire or the Operator, as the case may be, deems to be appropriate in its discretion, except that the Concessionaire or the Operator, as the case may be, shall include wages, benefits and other terms and conditions of employment that are at a minimum, comparable, in the aggregate, to the wages, benefits and other terms and conditions of employment such University Utility System Employee received as an employee of the University immediately prior to the Closing other than any tuition-based benefits offered to such University Utility System Employees prior to the Closing Date, which the Parties acknowledge and agree the Concessionaire will be unable to provide. Any and all employees of the Concessionaire and the Operator shall have met all reasonable background inspection and security requirements of the University, as promulgated from time to time. Nothing in this Agreement shall be construed or is otherwise intended to create joint employment by the University and the Concessionaire and/or the Operator, as the case may be, of the employees of the Concessionaire or the Operator; the Concessionaire or the Operator, as the case may be, shall have the right and obligation to supervise and direct the work of its employees.
- (k) *Ongoing Utility System Projects.* The University shall continue the construction of the Ongoing Utility System Projects, in accordance with applicable Law, until they have been completed in substantial accordance with the plans for such Ongoing Utility System Projects as of the Setting Date, provided that the University may, upon written notice to the Concessionaire, abandon or modify any or all Ongoing Utility System Projects. To the extent that the construction or completion of any Ongoing Utility System Project requires access to the Utility System, the Concessionaire hereby grants a non-exclusive license to the University to so access the Utility System as necessary to complete such Ongoing Utility System Projects (and the University shall use reasonable efforts to avoid undue interference with the operation of the Utility System) and shall reasonably cooperate with the University with respect to the completion of the

Ongoing Utility System Projects, which cooperation shall include (i) providing the University with notice if the Concessionaire becomes aware of any deviation from the University's approved plans and specifications for the applicable Ongoing Utility System Project and (ii) directing the University's Contractors to stop any work on the Ongoing Utility System Project if the Concessionaire reasonably believes that continuing such work would constitute an Emergency. Upon completion of an Ongoing Utility System Project, the University shall (i) deliver the Concessionaire written notice thereof, and, at such time, that Ongoing Utility System Project shall become part of the Utility System and the Concessionaire shall be granted a leasehold interest therein and (ii) either (A) assign the Concessionaire (or one or more third parties at the Concessionaire's direction) all contractors' warranties held by the University with respect to such Ongoing Utility System Project or (B) to the extent the University chooses not to so assign such warranties or such warranties are not so assignable, cooperate with the Concessionaire to provide the benefit of such warranties to the Concessionaire (or one or more third parties at the Concessionaire's direction). The University shall name the Concessionaire as an additional insured on its insurance policies with respect to those Ongoing Utility System Projects. For the avoidance of doubt, Ongoing Utility System Projects shall not be considered New Approved Capital Improvements. If the University elects to abandon an Ongoing Utility System Project, the Capped O&M Index shall be increased for the Fiscal Year in which such Capital Improvement is abandoned by the additional annual O&M Costs that the Concessionaire is required to incur due to the abandonment of such Ongoing Utility System Project, provided the Concessionaire provides reasonable proof of such additional O&M Costs and that such O&M Costs were unavoidable.

Section 2.6. Intended Treatment for Federal and State Income Tax Purposes.

(a) *Tax Treatment.*

- (i) The Parties intend for United States federal and state income Tax purposes that (A) the Closing Consideration will be treated as a payment and consideration for (I) the sale of the Utility System Assets and Utility Facilities, (II) a lease of the Utility System Land to the Concessionaire and (III) the grant to the Concessionaire of the exclusive right to provide the Utility Services to the University Campus in accordance with this Agreement; and (B) the Utility Fee is a separate fee and payment from the Closing Consideration and is not a payment for the sale of assets and lease described in Section 2.6(a)(i)(A) or otherwise but is in consideration of the services provided hereunder by the Concessionaire to the University.
- (ii) Notwithstanding Section 2.6(a)(i), this Section 2.6 only sets forth the intentions and agreements of the Parties with respect to United States federal and state income Tax purposes, and no provision of this Agreement is intended to, or shall in any way, transfer any fee interest in real property or improvements comprising the Utility System to the

Concessionaire for purposes of the provisions of the Idaho Code governing legal title to real property or the common law of Idaho or any other purpose whatsoever other than for United States federal and state income Tax purposes as described above.

- (iii) The Parties believe that the Closing Consideration is a reasonable payment for the sale and lease of the assets and the grant of the right referred to in Section 2.6(a)(i)(A) based on the fair market value of those assets and such right and that the Utility Fee is a reasonable fee based upon the services provided hereunder by the Concessionaire to the University with respect to providing the services hereunder to the University and is in consideration thereof.
- (iv) Subject to and consistent with Section 2.6(b) and Section 2.6(c), the University and the Concessionaire agree that the Closing Consideration will be allocated among the assets and rights that the Concessionaire is obtaining the use of pursuant to this Agreement using the residual allocation provisions of Section 1060 of the Code as provided therein and otherwise consistent in all respects with Schedule 19.
- (v) Any Concession Compensation paid to the Concessionaire hereunder shall be deemed an adjustment to the Utility Fee for tax purposes and shall not be deemed to be an adjustment to the Closing Consideration related to the sale and lease of the assets described in Section 2.6(a)(i)(A).
- (vi) The Parties intend that this Agreement will be treated as a service contract pursuant to Section 7701(e) of the Code with respect to the services provided hereunder by the Concessionaire to the University with respect to the Utility System, and the Parties shall use commercially reasonable efforts to cause such treatment under Section 7701(e) of the Code.
- (vii) The Parties intend that the University shall be considered the owner of all Capital Improvements made pursuant to this Agreement for GAAP accounting and state law purposes, provided that the Parties intend that the Concessionaire may claim a depreciable interest in all such Capital Improvements made by the Concessionaire during the Term for federal and state income Tax purposes.
- (viii) Notwithstanding the foregoing, if a Governmental Authority treats the Transaction, or any portion thereof, differently for state or federal Tax purposes, such treatment shall not impact, affect, modify or alter either Party's obligations hereunder including the Concessionaire's obligations under Section 10.4.
- (ix) Neither Party shall file any tax returns inconsistent with any treatment set forth in this Section 2.6(a), except as required by Law.

- (x) The Parties intend that, pursuant to the terms of this Agreement, as of the Closing Date, the Utility System shall be treated as being used for education related purposes for purposes of Idaho Code section 63-602E(3) in a manner that is proper for the operation of such state college or university.
- (xi) The Parties intend that the sale and lease described in Section 2.1 and this Section 2.6 involve the sale of substantially all of the operating assets of an identifiable segment of the business of the University, which exempts any sale or lease under these sections from Idaho sales tax under Idaho Code Section 63-3622K.
- (b) *Payment.* For purposes of Section 467 of the Code, and the Treasury Regulations promulgated thereunder, on the Bid Date the Concessionaire has provided to the University a schedule, (i) allocating the Closing Consideration attributable to the lease of the Utility System Land described in Section 2.6(a)(i)(A)(II) in equal amounts for each annual rental period; and (ii) demonstrating that such amounts bear “adequate interest” within the meaning of Treasury Regulation Section 1.467-2(b)(1)(ii) for each rental period or that such schedule is consistent with proportional rental accrual within the meaning of Treasury Regulation Sections 1.467-1(d)(2)(ii) and 1.467-2(c), and prior to the execution of ~~this~~the Original Agreement, the University and the Concessionaire have agreed on such schedule, which shall not thereafter be modified or altered by the Concessionaire without the Approval of the University. Such schedule shall constitute a specific allocation of such amounts for purposes of Section 467 of the Code. The University and the Concessionaire hereby agree to reasonably cooperate to modify the schedule referred to above if the amount of rental payments on which such schedule is based changes after the date such schedule is Approved or there is any other modification to the lease after the date thereof for which it would be advisable in the Concessionaire’s reasonable discretion (after good faith consultation and discussion with the University) to modify such schedule. Notwithstanding the foregoing allocation, except as set forth above, all such rental payments shall constitute a rental paid under a triple net lease which is non-refundable. If the University files a tax return for federal income tax purposes, the University shall, in such return, treat the Closing Consideration in a manner consistent with the allocation set forth in this Section 2.6(b).
- (c) *Allocation.* The Concessionaire has provided to the University, on the Bid Date, a schedule reflecting a reasonable allocation of the Closing Consideration (and all other capitalized costs) among the acquired assets in accordance with Section 1060 of the Code and the applicable Treasury Regulations for the University’s Approval, and the University and the Concessionaire have agreed on such schedule, which is attached hereto as Schedule 19, which shall not thereafter be modified or altered by the Concessionaire without the Approval of the University. The University shall file all federal and state income tax returns in a manner consistent with the allocation set forth on Schedule 19. Each of the

Concessionaire and the University acknowledges that the leasing of certain assets included in the Utility System as provided under this Agreement may result in the transfer of the tax ownership of such assets from the University to the Concessionaire.

Section 2.7. Closing Deliverables. At the Time of Closing, each Party shall execute and deliver all assets, agreements, bills of sale, assignments, endorsements, instruments and Documents as are reasonably necessary in the opinion of the other Party to effect the Transaction (and in form and substance that are reasonably satisfactory to such other Party).

Section 2.8. Memorandum of Lease. At the Time of Closing, the Parties shall execute and deliver a memorandum of lease (the "Memorandum of Lease") in the form attached hereto as Schedule 13, which the Concessionaire shall cause to be recorded in the Latah County Recorder's Office. To the extent that changes are made to this Agreement with respect to the Term, leased property or other material matters set forth in the recorded Memorandum of Lease, including the removal of property from service by the Utility System in accordance with Section 5.3, the Parties shall timely (and in no event longer than 10 Days after a request therefor) execute, deliver and record an amendment to the recorded Memorandum of Lease reflecting such changes. The Parties acknowledge that for purposes of recordation, a description of certain portions of the Utility System constituting Utility Facilities that are a real property interest, are depicted specifically but are recorded generally against the lot or parcel on which such Utility Facility is located. Each party shall have the right, from time to time, at its cost and expense to further refine by a metes and bounds legal description the specific location of the applicable Utility Facility, and subject to the other Parties' reasonable approval, may modify the Memorandum of Lease by recording an amendment thereto that shows the refined location description. In such instance, the modification to the Memorandum of Lease is subject to the other Party's reasonable approval, and both Parties shall sign a consent to the recording of the Memorandum of Lease upon its approval. The Parties agree not to record this Agreement itself.

Section 2.9. No Return of Closing Consideration. The Concessionaire shall have no right to have the Closing Consideration returned to it or refunded at any time after Closing, provided that, for the avoidance of doubt, this Section 2.9 shall not prohibit, preclude or adversely affect the Concessionaire's rights to compensation expressly set forth herein, including the right to receive the full Utility System Concession Value in those instances expressly set forth herein.

ARTICLE 3 TERMS OF THE CONCESSION

Section 3.1. Quiet Enjoyment and Present Condition.

- (a) *Quiet Enjoyment.* The University agrees that, subject to the University's remedies upon a Concessionaire Default, the Concessionaire shall, at all times during the Term, be entitled to and shall have quiet enjoyment of the Utility System and the rights and privileges granted to the Concessionaire hereunder, subject to the provisions contained in this Agreement and the rights of other parties to use the Tunnels. The University and the Concessionaire acknowledge

that the Concessionaire's rights to use, control and possess the Utility System and to collect and retain the Utility Fee are subject to the right of the University, in accordance with the terms of this Agreement, to monitor compliance with this Agreement to ensure that the Utility System is used and operated as required by this Agreement. Any entry by the University or its Representatives into the Utility System required or permitted under this Agreement shall not constitute a reentry, trespass or a breach of the covenant for quiet enjoyment contained in this Agreement. The University shall, at all times during the Term, defend its fee or leasehold interest title, as the case may be, to the Utility System, the Concessionaire's leasehold interest in and to the Utility System and the rights granted to the Concessionaire hereunder, or any portion thereof, against any Person claiming any interest adverse to the University or the Concessionaire in the Utility System, or any portion thereof, except where such adverse interest arises as a result of the act, omission, negligence or willful misconduct of, or violation of applicable Law by, the Concessionaire, its Affiliates or their respective Representatives.

- (b) *Present Condition.* Subject to Section 2.5(h) and except as specifically set forth herein, the Concessionaire understands, agrees and acknowledges that the Concessionaire (i) by the execution of ~~this~~the Original Agreement¹⁴, agrees/agreed to accept the Utility System "AS IS" at the Time of Closing and (ii) has inspected the Utility System and is aware of its condition and acknowledges that the University neither has made nor is making any representation or warranty, other than as expressly set forth herein, express or implied, regarding the condition of the Utility System (or any part thereof) or its suitability for the Concessionaire's proposed use, provided that nothing in this Section 3.1(b) shall preclude the Concessionaire from making repairs or replacements or Capital Improvements to the Utility System in accordance with the terms of this Agreement (including, for the avoidance of doubt, the provisions regarding Approval of Capital Improvements set forth in Section 4.3 and the provisions regarding inclusion of New Approved Capital Improvements and O&M Costs in the calculation of the Utility Fee in accordance with Schedule 5) as a result of the Utility System's condition at the Time of Closing.
- (c) *Legal Title to Real Property and Improvements.* For the avoidance of doubt, and notwithstanding anything to the contrary contained in Section 2.6, all real estate and improvements now or hereafter forming part of the Utility System shall be the fee-owned property of the University for GAAP and state law purposes, and are subject to the terms and conditions of this Agreement.

Section 3.2. Utility System Operations.

- (a) *Use.* Except as otherwise specifically provided herein, the Concessionaire shall, at all times during the Term, (i) be responsible for all aspects of the Utility System Operations, including providing the Utilities from temporary sources for

¹⁴ NTD: This change is necessary to document acceptance at time of closing.

construction projects and special events as identified by the University and (ii) maintain and operate the Utility System and cause the Utility System Operations to be performed in accordance with the provisions of this Agreement, including the Performance Standards, Prudent Industry Practices and applicable Law. Upon the University's request, the Concessionaire shall provide an estimate for the costs associated with providing Utilities from temporary sources for construction projects or special events identified by the University. In connection with such maintenance, the Concessionaire may contract with a third party for certain tasks, such as janitorial services. Except for such additional purposes permitted pursuant to Section 3.15(c), the Concessionaire shall, at all times during the Term, cause the Utility System to be used exclusively for the Utility System Purposes and continuously open and operational for the Utility System Purposes in accordance with the Performance Standards. Notwithstanding the foregoing, the Concessionaire may cease keeping the Utility System or a portion thereof continuously open and operational for the Utility System Purposes (A) as specifically permitted under this Agreement, (B) as required by applicable Law, (C) as necessary to comply with any other requirement of this Agreement (including closures related to the performance of Capital Improvements or maintenance or repair activities as required by the Performance Standards), (D) as necessary for a Delay Event or (E) as necessary for temporary closures required to address Emergencies or public safety; provided, however, that in the event of any temporary suspension of Utility System Operations pursuant to any of clauses (A) through (E) of this Section 3.2(a), such suspension shall be limited as much as practicable so as to allow all other Utility System Operations to continue.

- (b) *University Campus.* Notwithstanding anything to the contrary contained herein, the Concessionaire shall operate the Utility System and provide the Utility Services in a manner that does not interfere with or impair the operation of the University Campus or any other real property owned by the University, including any special events conducted on the University Campus. Except in the case of an Emergency or as otherwise provided for in Section 3.2(e) or Section 3.2(j), if the Concessionaire, in performing the Utility System Operations, determines it is reasonably necessary to access or disturb any portion of the University Campus or any other real property owned by the University, excluding the Tunnels and the Utility System Land, it shall, to the extent possible given the circumstances, provide the University at least 30 Days' prior written notice and the Concessionaire shall comply with any reasonable requirements or restrictions on such disturbance imposed by the University, including limiting the time in which the Concessionaire can so access and/or disturb the portion of the University Campus or any other real property owned by the University to specific hours. In accessing any portion of the University Campus or any other real property owned by the University pursuant to the license granted hereunder, the Concessionaire shall also abide by any restrictions and requirements generally imposed by the University on such access, as communicated to the Concessionaire from time to time. To the extent that, in operating and maintaining the Utility System, the Concessionaire damages any

portion of the University's real or personal property, including the landscape of the University Campus, the University's information technology network or any other real property owned by the University, the University's outdoor lighting, traffic signals, irrigation equipment and communications equipment and such damage was neither (i) Approved by the University in accordance with this Agreement nor (ii) included as part of the scope of work Approved by the University related to such operations and maintenance, then the Concessionaire shall, in coordination with University personnel, promptly cause such property to be repaired to substantially the same or, solely at the Concessionaire's election, better condition that existed prior to such damage, and the cost incurred therewith shall not be included in O&M Costs or otherwise recovered as a part of the Utility Fee provided, however, that the Concessionaire shall be entitled to make a claim on any applicable Concessionaire Required Coverage.

- (c) *Costs and Expenses.* Except as otherwise specifically provided herein, the Concessionaire shall, at all times during the Term, pay or cause to be paid all costs and expenses of the Utility System Operations as and when the same are due and payable.
- (d) *Assumed Liabilities and Excluded Liabilities.* The Concessionaire agrees to assume and discharge or perform when due all debts, liabilities and obligations whatsoever relating to the Utility System or the Utility System Operations that occur, arise out of or relate to, or are based on facts or actions occurring during the Term but only to the extent such debts, liabilities or obligations do not arise from or relate to any breach by the University of any covenant, representation or warranty set forth in this Agreement (collectively, the "Assumed Liabilities"); provided, however, that the Assumed Liabilities shall not include, and the University shall perform or cause to be performed and discharge or cause to be discharged as and when due, any debts, liabilities and obligations (i) with respect to the University's obligations under this Agreement, (ii) arising out of the Utility System or any Utility System Operations (including with respect to any University Utility System Employee) prior to the Time of Closing, (iii) arising under any Environmental Law and related to (1) the ownership, operation or condition of the Utility System prior to the Time of Closing or (2) the Release on or from, presence on or in, or other existence on the Utility System or its subsurface or the Tunnels of any Hazardous Substance at any time prior to the Time of Closing and including (A) the abatement, handling, disposal or removal of any asbestos or other Hazardous Substances present at the Time of Closing in the Utility System as required by any Environmental Law in connection with the repair, maintenance, operation or construction activities permitted or required to be performed under this Agreement and (B) any known or unknown environmental conditions relating to the Utility System or its subsurface that existed prior to the Time of Closing the manifestation of which occurs following the Time of Closing, which environmental obligations the University shall perform and discharge when due, except in any case to the extent exacerbated by the Concessionaire or its Representatives or caused by any action of the Concessionaire or its Representatives, (iv) arising out of the University's rights

under this Agreement to test, inspect, audit, repair, maintain or operate the Utility System without impairment of the University's remedies for a Concessionaire Default and (v) with respect to the Ongoing Utility System Projects that have not yet become a part of the Utility System in accordance herewith (collectively, the "Excluded Liabilities").

- (e) *Right of Entry and Access to the Public Way.* Subject to Section 3.19, the University hereby grants to the Concessionaire and its Representatives a non-exclusive license to enter upon, in, under, over and across the Public Way to such extent and at such times as shall be necessary or desirable for the Concessionaire to access the Utility System in order to conduct Utility System Operations, including operating, maintaining, inspecting, repairing and managing Utility System properties, including the Utility System Assets and all supporting structures and appurtenances thereto, and installing monitoring or observation technology or equipment reasonably necessary for Utility System Operations. The rights granted pursuant to this Section 3.2(e) do not include the right to block, impede or otherwise obstruct traffic on the Public Way, and the Concessionaire shall, enter, access and perform work in, on or over the Public Way in accordance with the Performance Standards. The rights granted to the Concessionaire under this Section 3.2(e) neither create an interest in real property nor do they create a priority in favor of the Concessionaire over any other user of such areas and are subject to the Performance Standards and all provisions of Law relating to the conduct of a private business or franchise in the Public Way.
- (f) *Mapping and Marking.* The Concessionaire shall be responsible for marking and mapping all portions of the Utility System in accordance with the Performance Standards.
- (g) *Deemed Planned Outage.* The Concessionaire shall have the right to propose to shut down a portion of the Utility System such that such portion shall not transmit Utilities provided by that portion of the Utility System if the Concessionaire reasonably believes that such a shutdown will avoid additional costs in excess of the costs of such shutdown or lengthier shutdowns of the Utility System or a portion thereof later. If the University Liaison agrees to such shut down (which agreement must be in writing or by e-mail from the University Liaison), then it shall be treated as a Planned Outage. The University Liaison may make this determination in its sole discretion. If the University Liaison does not Approve such shutdown, then it will be considered an Unplanned Outage if the Concessionaire elects to proceed with such shutdown.
- (h) *Emergency Shutdown.* If there is a circumstance where the continued operation of a portion of the Utility System creates an Emergency (other than an Unplanned Outage), then the Concessionaire shall have the right, directly or through its automatic protection system or the Operator, to shut down the applicable portion of the Utility System to address such circumstance, provided that the Concessionaire shall comply with the provisions of Section 8.1 and the

relevant portion of the Performance Standards, as if such shutdown were an Unplanned Outage. The Concessionaire shall perform the corrective action to address such circumstance as soon as reasonably practicable. Within 10 Business Days after the shutdown and repair of the applicable portion of the Utility System, the Concessionaire shall provide the University with pertinent information on such circumstance and such other relevant information within the Concessionaire's possession or control that is requested by the University, and the University shall determine, in its reasonable judgment, whether such shutdown shall constitute an Unplanned Outage for purposes of determining the applicable Key Performance Indicator. For the avoidance of doubt, such determination shall not affect the Concessionaire's obligation to treat such shutdown as an Unplanned Outage for purposes of compliance with the Performance Standards.

- (i) *Other Public Streets.* To the extent that the performance of the Utility System Operations requires access to streets, alleys, driveways or sidewalks owned or controlled by a Governmental Authority, the University shall, at no out-of-pocket cost to the University, use commercially reasonable efforts to cooperate with the Concessionaire to secure such access from the applicable Governmental Authority consistent with the University's past practice.

Section 3.3. Operator.

- (a) *Engagement.* The Utility System Operations shall, at all times during the Term, be under the direction and supervision of an active operator with the expertise, qualifications, experience, competence, skills and know-how to perform the Utility System Operations in accordance with this Agreement, Prudent Industry Practices and applicable Law (an "Operator") who may be (but is not required to be) the Concessionaire itself. The Operator on the first Day of the Term shall be the Concessionaire unless the Concessionaire has designated another Person to be the Operator and such Person has been Approved in accordance with Section 3.3(b); provided the Parties acknowledge Sacyr Plenary Idaho Operators LLC, a Delaware limited liability company was Approved as Operator as of the Time of Closing. The Concessionaire shall not engage or appoint a replacement Operator unless the University has Approved such Operator and the terms (including fees charged by such replacement Operator) of any such engagement are commercially reasonable; provided, however, that a Change in Control of an Operator shall be deemed to be the appointment of a replacement Operator subject to the University's Approval; provided, further, that for purposes of this Section 3.3(a), the definition of "Equity Participant" and clauses (a) through (g) of the definition of "Change in Control" shall be read and apply as though "Operator" were substituted for "Concessionaire"; provided, further, that if the University does not provide the Concessionaire with the relevant Approval, the Concessionaire shall be entitled to appoint an interim Operator for a period of up to 180 Days from the date of appointment of such interim Operator. This interim Operator may be selected without Approval by the University so long as the Concessionaire reasonably determines that the interim Operator meets the

following criteria: (A) the interim Operator has experience in operating Comparable Utility Systems and (B) the interim Operator (or any guarantor of its obligations) has a tangible net worth reasonably sufficient to carry out its obligations and responsibilities as Operator. The Concessionaire shall not extend the term of any interim Operator beyond 180 consecutive Days or appoint a successor interim Operator after such 180-Day period. The Operator shall at all times be subject to the direction, supervision and control (by ownership, contract or otherwise) of the Concessionaire, and any delegation to an Operator shall not relieve the Concessionaire of any obligations, duties or liability hereunder. The Concessionaire shall immediately notify the University upon the termination or resignation of an Operator. The rights of the Operator regarding the continued operation of the Utility System shall terminate without penalty at the election of the University or the Operator upon 5 Business Days' notice to such Operator or the University, as applicable, upon the termination of this Agreement. Except as otherwise expressly set forth herein, the Operator shall have no interest in, or rights under, this Agreement or the Utility System unless the Operator is the Concessionaire itself.

- (b) *Approval.* The University's Approval of a proposed replacement Operator may be withheld only if the University reasonably determines that the engagement of such proposed Operator is prohibited by applicable Law or this Agreement, or such proposed Operator is not capable of performing the Utility System Operations in accordance with this Agreement and Prudent Industry Practices, which determination shall be based solely upon one or more of the following factors: (i) the ability of the proposed Operator to operate the Utility System in a manner that complies with the Performance Standards; (ii) the financial strength, capitalization and integrity of the proposed Operator, its direct or indirect beneficial owners and some or all of their respective Affiliates providing a guaranty of the Operator's obligations (which guaranty shall not be required to run to the benefit of the University); (iii) the experience of the proposed Operator in operating Comparable Utility Systems; (iv) the background and reputation of the proposed Operator, its direct or indirect beneficial owners, each of their respective officers, directors and employees and each of their respective Affiliates (including the absence of criminal, civil or regulatory claims or actions against any such Person and the quality of any such Person's past or present performance on other projects); and (v) the proposed terms of the engagement of the proposed Operator, including the fee being charged by the Operator, length of the term of the engagement and any restrictions on transfer by the Operator of its obligations and change in control of the proposed Operator.

- (c) *Removal.*
- (i) If the Operator fails to operate the Utility System in compliance with the Performance Standards or fails to meet the Target for any Key Performance Indicator, and
- (A) such failure is the material breach of a material requirement of the Performance Standards other than a requirement that is also a Key Performance Indicator, the University may provide written notice to the Operator and the Concessionaire setting forth such failure. If the Operator does not cure such failure within 30 Days of said written notice (or, if such cure or correction cannot reasonably be accomplished during such 30-Day period, within such longer period as is reasonably required to accomplish such cure or correction, provided the Concessionaire, either directly or through the Operator, has commenced such cure or correction within 30 Days of said written notice and diligently prosecutes the same to completion), then (i) the University may, upon notice to the Concessionaire, (A) cure any such failure and (B) the Concessionaire shall reimburse the University any and all costs related to such cure and/or correction; and (ii) the University may direct that the Concessionaire remove the Operator pursuant to the written order of senior University officials designated by the President of the University (or his or her designee) in writing for such purpose or otherwise with respect to assessing the performance of the Operator (the “Senior Officials”); or
- (B) such failure results in an Emergency, then the University may, upon notice to the Concessionaire, (i) immediately cure any such failure after endeavoring to provide the Concessionaire notice appropriate under the circumstances (which may include telephone notice) and (ii) the Concessionaire shall reimburse the University any and all costs related to such cure and/or correction.
- (ii) Notwithstanding the foregoing, if (A) within any Operator Evaluation Period, at least 3 Repetitive Failures occur, (B) a Major KPI Event for the same Key Performance Indicator occurs for 3 consecutive Fiscal Years or (C) 3 Major KPI Events occur in any given Fiscal Year, then the University, in addition to its right to KPI Compensation, may direct that the Concessionaire remove the Operator pursuant to the written order of the Senior Officials.
- (iii) The University shall provide the Concessionaire and the Operator with no less than 30 Days’ prior written notice of the time, date, place and subject matter of any meeting of the Senior Officials at which a decision to remove the Operator will be considered, and both the Concessionaire and the Operator shall be afforded a reasonable opportunity to present

testimony and evidence at such meeting and to present to the Senior Officials written objections to any proposed removal determination. Any written order of the Senior Officials removing the Operator shall contain written determinations as to the reasons for removal of the Operator. Within 30 Days following the effective date of such decision, the Concessionaire shall (x) provide the University with a transition plan to remove the then current Operator and replace such Operator with either (A) a new Operator that is Approved by the University pursuant to Section 3.3(b), (B) an interim Operator in accordance with Section 3.3(a) or (C) to the extent the Concessionaire was not the removed Operator, the Concessionaire, and then (y) carry out such transition plan within 30 Days following the delivery thereof.

- (iv) For the avoidance of doubt, if there is a dispute as to whether there has been a failure to meet the Performance Standards or the Target for any Key Performance Indicator, such dispute shall be subject to resolution in accordance with Article 18.
- (d) *Sole Remedy.* Other than the University's right to KPI Compensation pursuant to Article 15, notwithstanding anything to the contrary contained herein, the University's right to remove the Operator pursuant to Section 3.3(c) shall constitute the Concessionaire's sole and exclusive liability and the University's sole and exclusive remedy relating to a failure to meet a requirement of the Performances Standards or a KPI Event.
- (e) *Operator Fee.* Unless otherwise Approved by the University, the fee payable by the Concessionaire to the Operator shall not exceed \$3,700,000 (the "Maximum Annual Operator Fee") per Fiscal Year, Adjusted for Inflation, starting with the first Fiscal Year, provided that, to the extent any changes to the Capped O&M Index in accordance with Section 2.5(d), Section 3.23, Section 5.1 or Section 6.3(b) or any Uncapped O&M Costs require a material increase in the scope of work to be performed by the Operator, as demonstrated to the reasonable satisfaction of the University, the Maximum Annual Operator Fee shall be increased accordingly, as agreed by the University and Concessionaire, each acting reasonably. Notwithstanding the foregoing, if the Operator is replaced pursuant to the terms hereof, the Maximum Annual Operator Fee shall be replaced with the fee charged by the Operator in the first full Fiscal Year of such replacement tenure as Operator hereunder. For the avoidance of doubt, the amount of the Maximum Annual Operator Fee shall not affect the calculation of the Capped O&M Index for the Fiscal Year ending June 30, 2021; provided that, for the further avoidance of doubt, the Maximum Annual Operator Fee shall affect the calculation of the Capped O&M Index thereafter in accordance with the definition of "Capped O&M Index" and the relevant provisions of this Agreement.
- (f) *IRWA Membership.* The Concessionaire shall cause the Operator, at all times, to maintain an active membership in the Idaho Rural Water Association ("IRWA")

and to abide by all requirements of the IRWA, and the University shall use commercially reasonable efforts to assist in connection with applications related to such membership. If the University reasonably expects to incur any out-of-pocket costs in connection with providing assistance to the Operator as provided in the preceding sentence, it shall have no obligation to provide such assistance until the Concessionaire or the Operator commits to the prompt reimbursement of such out-of-pocket costs in writing.

Section 3.4. Authorizations; Qualifications.

- (a) *Compliance.* The Concessionaire shall obtain, comply with, promptly renew and maintain in good standing all Authorizations, and the University shall use commercially reasonable efforts to assist the Concessionaire in obtaining, complying with, renewing and maintaining in good standing all such Authorizations, including those that the University was not required to obtain in connection with its operation of the Utility System prior to the Time of Closing. If the University reasonably expects to incur any out-of-pocket costs in connection with providing assistance to the Concessionaire as provided in the preceding sentence, it shall have no obligation to provide such assistance until the Concessionaire commits to the prompt reimbursement of such out-of-pocket costs in writing. Nothing in this Agreement, including Section 2.1, shall be deemed to waive or modify any Authorization required to be obtained by the Concessionaire or any other Person in connection with the Utility System, the Utility System Operations or any activities generating the Utility Fee.
- (b) *Qualifications.* The Concessionaire shall, at all times during the Term, maintain in full force and effect its existence and all qualifications necessary to carry on its business pertaining to the Utility System Operations, including all rights, franchises, licenses, privileges and qualifications required in connection with the Utility System Operations.

Section 3.5. No Encumbrances.

- (a) *By the Concessionaire.* The Concessionaire shall not do any act or thing that will create any Encumbrance (other than a Permitted Concessionaire Encumbrance) against the Utility System and shall promptly remove any Encumbrance (other than a Permitted Concessionaire Encumbrance) against the Utility System, unless the Encumbrance came into existence as a result of an act of or omission by the University or a Person claiming through it which in turn was not caused by an act or omission of the Concessionaire. The Concessionaire shall not be deemed to be in default hereunder if the Concessionaire continuously, diligently and in good faith contests any such Encumbrance, or the validity thereof (or causes such contest), by appropriate legal proceedings that shall operate to prevent the foreclosure of any such Encumbrance; provided that the Concessionaire has (i) given advance notification to the University that it is the intent of the Concessionaire to contest the validity or collection thereof or cause such contest and (ii) unless a bond or other security is provided in

connection with such proceedings, given a satisfactory indemnity to the University or deposited with the University a Letter of Credit, indemnity bond, surety bond, cash or Eligible Investment reasonably satisfactory to the University in an amount equal to the amount of the claim or Encumbrance, plus such interest and penalties, court costs, or other charges as the University may reasonably estimate to be payable by the Concessionaire at the conclusion of such contest or as is required to provide insurance over any potential Encumbrance; provided, however, that unless the Concessionaire is required by GAAP to maintain any security in favor of a purported beneficiary of such Encumbrance, in the event such Letter of Credit bond, cash or Eligible Investment shall be so deposited, the same shall be held by the University until such claim or other imposition shall have been released and discharged and shall thereupon be promptly returned to the Concessionaire, less any amounts reasonably expended by the University to procure such release or discharge or any loss, cost, damage, reasonable attorneys' fees or expense incurred by the University by virtue of the contest of such Encumbrance.

- (b) *By the University.* The University shall not do any act or thing that will create any Encumbrance (other than a Permitted University Encumbrance) against the Utility System and shall promptly remove any Encumbrance (other than a Permitted University Encumbrance) against the Utility System that came into existence as a result of an act of or omission by the University or a Person claiming through the University. The University shall not be deemed to be in default hereunder if the University continuously, diligently and in good faith contests any such Encumbrance, or the validity thereof (or causes such contest), by appropriate legal proceedings that shall operate to prevent the foreclosure of any such Encumbrance; provided that the University has given advance notification to the Concessionaire that it is the intent of the University to contest the validity or collection thereof or cause such contest.
- (c) *Removal.* Each Party, if requested by the other Party and at such other Party's costs and expense, shall use its reasonable efforts to assist such other Party in attempting to remove any Encumbrance that has come into existence as a result of an act of or omission by such other Party (other than a Permitted University Encumbrance or a Permitted Concessionaire Encumbrance); provided that nothing herein shall obligate the University to waive, modify or otherwise limit or affect the enforcement by the University of any applicable rule, procedure or policy of the University whether or not with respect to the Utility System.

Section 3.6. Single Purpose Covenants; Credit Rating. Subject to Section 3.15(c), the Concessionaire shall, at all times during the Term, (i) be formed and organized solely for the purpose of (A) owning the Concessionaire Interest, (B) owning, leasing, operating, improving, using, possessing, controlling and otherwise dealing with the Utility System, (C) collecting from the University the Utility Fee in consideration of providing the services hereunder to the University and any fees from third parties to which it provides services to the extent permitted by Section 3.15(c), (D) financing its interest in the Utility System, and (E) carrying out the Utility Services and other activities permitted pursuant to this Agreement (and any activities

reasonably incidental thereto), (ii) not engage in any business unrelated to clause (i) above, (iii) not have any assets other than those related to its activities in accordance with clauses (i) and (ii) above, (iv) except as appropriate for Tax reporting purposes, maintain its own separate books and records and its own accounts, (v) observe all corporate, limited partnership or limited liability company, as applicable, formalities and do all things necessary to preserve its existence, (vi) not guarantee or otherwise obligate itself with respect to the debts of any other Person, (vii) except as expressly permitted hereby or by any Leasehold Mortgage, or in the ordinary course of business of the Utility System, not pledge its assets for the benefit of any other Person, and (viii) maintain adequate capital in light of its contemplated business operations. In addition, if ~~the Concessionaire issues or refinances~~ any Leasehold Mortgage Debt is issued or refinanced¹⁵ after the Closing Date, at the time of such issuance, refinancing or entry, such Leasehold Mortgage Debt shall have an investment grade credit rating, as determined by at least one of the Credit Rating Agencies, and shall provide written evidence of such rating to the University at the same time as such issuance, refinance or entry. The cost and expense paid to the applicable Credit Rating Agency for maintaining the credit rating of the Leasehold Mortgage Debt with a Credit Rating Agency shall, for the first three Fiscal Years (and any partial Fiscal Year) after the Closing be treated as Uncapped O&M Costs and shall not be included in the calculation of the Capped O&M Index, and, after such period has elapsed, those reasonable, actual out-of-pocket costs shall be considered Capped O&M Costs and included in the Capped O&M Index by taking them into account in the calculation of historical Capped O&M Costs for the prior 3 Fiscal Years in the manner specified in the definition of “Capped O&M Index” in Schedule 5).

Section 3.7. Rights of the University to Access and Perform Work on the Utility System and Utilize Space for Energy Resources and Research Purposes.

- (a) *Reservation of Rights.* The University reserves (for itself and any of its Representatives, grantees, tenants, contractors, mortgagees, licensees, concessionaires and others claiming by, through or under the University) and shall, at all times during the Term, have the right to enter the Utility Facilities and have access to the Utility System in response to any of the following events or circumstances or for any of the following purposes, provided that (x) with respect to Section 3.7(a)(i) and Section 3.7(a)(ii), such right is to be exercised at all reasonable times upon reasonable prior notice to the Concessionaire, (y) with respect to Section 3.7(a)(iii), such right is to be exercised at all reasonable times upon reasonable prior notice to the Concessionaire if practicable under the circumstances, and (z) with respect to Section 3.7(a)(iv), Section 3.7(a)(v) and Section 3.7(a)(vi), such right is to be exercised at all reasonable times with the University to request, with reasonable prior notice, the Concessionaire’s consent to the exercise of such right, which consent shall not be unreasonably withheld, conditioned or delayed, provided that if the Concessionaire has not responded to such request within 5 Business Days, it shall be deemed to have consented to such exercise:

¹⁵ NTD: This change is necessary because Leasehold Mortgage Debt could be financed by Concessionaire’s parent.

- (i) to inspect the Utility System, including performance of an assessment of the condition of the Utility System or any component thereof, or determine whether or not the Concessionaire is in compliance with its obligations under this Agreement or applicable Law pursuant to Section 8.3;
- (ii) if a Concessionaire Default then exists, subject to the cure rights of any Leasehold Mortgagee under Section 19.3, to make any necessary repairs to the Utility System and perform any work therein pursuant to Section 16.1(b)(iii) in accordance with Prudent Industry Practices;
- (iii) in the event of an Emergency or danger that threatens to cause injury to individuals (or damage to property) or to materially impair the continuous operation of the Utility System and if the Concessionaire is not then taking all necessary steps to rectify or deal with said Emergency or danger, to take actions as may be reasonably necessary to rectify such Emergency or danger in accordance with Prudent Industry Practices, in which event the University shall promptly give the Concessionaire written notice of such measures taken by the University;
- (iv) at its own cost and expense, to (A) install, design, manage, maintain, repair and rehabilitate any existing or future safety measures for the University Campus (whether provided by the University or third parties at the University's instruction) in, on, under, across, over or through the Utility System (including surveillance equipment and other safety equipment), (B) grant easements and rights on, over, under or within the Utility System for the benefit of suppliers or owners of any such measures and (C) use the Utility System in connection with any such installation, design, management, maintenance, repair or rehabilitation (provided that notwithstanding the foregoing clauses (A), (B) and (C), the Concessionaire shall have the right, at all times during the Term, to install, design, manage, maintain, repair and rehabilitate safety measures for its own account (and not for lease, resale or service to third parties) to the extent that the said safety measures are necessary for the Utility System Operations or as otherwise permitted under this Agreement);
- (v) at its own cost and expense, to (A) install, design, manage, maintain, repair and rehabilitate any existing or future utilities or similar services (whether provided by the University or third parties at the University's instruction) that are not part of the Utility System and do not provide Utilities in, on, under, across, over or through the Utility System (including water lines, sewer lines, fiber optic cable, other communications and other equipment), and (B) grant easements and rights on, over, under or within the Utility System for the benefit of suppliers or owners of any such utilities or services that are not part of the Utility System (provided that notwithstanding the foregoing clauses (A) and (B), the Concessionaire shall have the right, at all times during the Term, to

install, design, manage, maintain, repair and rehabilitate utilities or other services for its own account (and not for lease, resale or service to third parties) to the extent that the said utilities or services are necessary for the Utility System Operations); and

- (vi) at its own cost and expense (except as otherwise expressly provided in this Agreement) and solely in accordance with the terms hereof, to do any other act or thing that the University may be obligated to do or have a right to do under this Agreement;

provided, however, that the University shall (A) not be obligated to make any payments to the Concessionaire for such access (other than Concession Compensation to the extent required hereunder) and the University shall use reasonable efforts to minimize interference with the Utility System Operations in connection with any entry on the Utility System pursuant to this Section 3.7(a), (B) not have access to any software or other intangibles of the Concessionaire and (C) comply with the Concessionaire's reasonable safety protocols and requirements to the extent provided in writing in advance to the University. Any entry to or action on the Utility System pursuant to clauses (iv), (v) and (vi) of this Section 3.7(a) shall be a Compensation Event.

- (b) *Access Rights.* The University and any of its Representatives, grantees, tenants, contractors, mortgagees, licensees, concessionaires and others claiming by, through or under the University, during the progress of any work referred to in this Section 3.7 shall have all necessary easement and access rights to the Utility System. To the extent that the University undertakes work or repairs in the Utility System under this Section 3.7 or any other provision of this Agreement, such work or repairs shall be commenced and diligently completed in a good and professional manner, in accordance with any applicable Performance Standards and the Concessionaire's reasonable safety protocols and procedures to the extent provided in writing in advance to the University and in such a manner as not to unreasonably interfere with the Concessionaire's conduct of business in or use of such space.
- (c) *Renewable and Other Energy Resources.* The Concessionaire and the University recognize the value of exploring the use of renewable energy, energy storage and other energy resources, and, consistent therewith, the University reserves the right to use portions of the Utility System for the installation, operation, replacement and repair of energy apparatus, equipment, or improvements, including solar panels as well as collection and distribution facilities in accordance with Prudent Industry Practices and applicable Law. The University shall have the right to install or replace such energy apparatus, equipment, or improvement. Prior to any such installation, the University shall provide the Concessionaire written notice that includes the plans and schedule for completing such installation or replacement or, alternatively, the University may provide the Concessionaire a written notice requiring it to complete such installation or replacement as part of a University Directive, which notice shall

include the plans, specifications, schedule (including the liquidated damages for failure to meet such schedule) and cost therefor. If the Concessionaire is directed to install or replace such energy apparatus, equipment, or improvement, (i) it shall do so in accordance with the terms and conditions of the University's notice and (ii) to the extent such energy apparatus, equipment, or improvement is a Capital Improvement, it shall, to the extent the costs therefor are incurred by the Concessionaire, be deemed to be a Capital Improvement Approved in accordance with Section 4.3(c)(i) (including the budgeted costs and liquidated damages set forth in such notice), and, once installed, shall be deemed part of the Utility System. Any such access contemplated by this Section 3.7(c) shall comply with the access right requirements set forth above in Section 3.7(b). In connection therewith, upon the request of the University, the Concessionaire agrees that it shall cause any such energy apparatus, equipment, or improvement to be connected to, or become part of, the Utility System in a manner that complies with the Concessionaire's reasonable interconnection and generation standards and is in accordance with Prudent Industry Practices and applicable Law, and that the Concessionaire will use any energy resources generated or stored by such apparatus, equipment, or improvement in the operation of the Utility System to the extent such energy is made available for use in the Utility System. To the extent the costs incurred for such interconnection (including any costs of installation, operation, replacement and repair) do not qualify as O&M Costs, such costs shall be reimbursed to the Concessionaire as Concession Compensation.

- (d) *Effect of Reservation.* Any reservation of a right by the University and any of its Representatives, grantees, tenants, contractors, mortgagees, licensees, concessionaires and others claiming by, through or under the University to enter the Utility System and to make or perform any repairs, alterations, Restoration or other work in, to, above, or about the Utility System which is the Concessionaire's obligation pursuant to this Agreement, shall not be deemed to (i) impose any obligation on the University to do so, (ii) render the University liable to the Concessionaire or any other Person for the failure to do so or (iii) relieve the Concessionaire from any obligation to indemnify the University as otherwise provided in this Agreement. Nothing in this Agreement shall impose any duty upon the part of the University to do any work required to be performed by the Concessionaire hereunder and performance of any such work by the University and any of its Representatives, grantees, tenants, contractors, mortgagees, licensees, concessionaires and others claiming by, through or under the University shall not constitute a waiver of the Concessionaire's default in failing to perform the same. For the avoidance of doubt and notwithstanding any other provision of this Agreement, access to the Utility System by the University and its staff, students and Representatives shall be subject to and in accordance with the Concessionaire's reasonable access and safety protocols to the extent provided in writing in advance to the University.
- (e) *Energy Research and Education.* The Concessionaire acknowledges that energy research and education is a significant focus of the University. The University

and its energy industry research partners recognize the value of conducting applied energy research in real-world settings, and, consistent therewith, the University reserves the right to use portions of the Utility Facilities for the installation, evaluation, testing, operation, and replacement of energy apparatus, equipment, or improvements to serve research and academic purposes. Any such access contemplated by this Section 3.7(e) shall (i) comply with the access right requirements set forth above in Section 3.7(b), (ii) be in accordance with Prudent Industry Practices and applicable Law and (iii) comply with the Concessionaire's reasonable safety protocols and procedures to the extent provided in writing in advance to the University. In connection therewith, upon the request of the University, the Concessionaire agrees that it shall cooperate and take all reasonable actions to cause any such energy research apparatus, equipment, or improvement to be connected to the Utility Systems, including associated data collection apparatus, equipment, or improvement, in a manner that complies with the Concessionaire's reasonable interconnection standards, provided that, unless disclosure is required by applicable Law, the University shall maintain any information received by the University in connection therewith confidential in accordance with Section 8.2(b) if the Concessionaire has identified such information as a trade secret. The Concessionaire agrees that any intellectual property, including copyrights, patents, trade secrets and trademarks, created or generated by or related to any of the University's actions under this Section 3.7(e) shall not be considered owned or created by the Concessionaire, notwithstanding that the University or its energy industry research partners may access or use the Utility System with respect thereto, and the Concessionaire shall have no rights with respect thereto unless the University enters into a separate agreement with the Concessionaire granting such rights. To the extent the costs incurred for such connections do not qualify as O&M Costs, such costs shall be reimbursed to the Concessionaire as Concession Compensation. The Concessionaire also acknowledges that as part of the University's research, the University may request information regarding the Utility System, which information shall be provided pursuant to Section 3.12(a).

Section 3.8. Payment of Taxes. The Concessionaire shall pay when due all Taxes payable during the Term in respect of the use of, operations at, occupancy of or conduct of business in or from the Utility System, including any Property Taxes in respect of the Utility System, subject to this Section 3.8. The Parties acknowledge that, as of the Bid Date, the Utility System is exempt from Property Taxes. To the extent the Utility System or any portion thereof becomes not exempt from any Property Taxes due to any cause other than acts or omissions of the Concessionaire or its Representatives (other than those actions or inactions that the Concessionaire is directed or obligated to take pursuant to this Agreement, including in order to comply with the Performance Standards, and the execution of this Agreement), the actual costs of any resulting Property Taxes payable during the Term shall be included in Uncapped O&M Costs. The Concessionaire shall use commercially reasonable efforts to reduce the amount of Taxes required to be paid by it or the University. The University reserves the right, without being obligated to do so, to pay the amount of any such Taxes not timely paid by the Concessionaire and which are not being contested by the Concessionaire, and the amount so paid by the University shall be deemed additional consideration hereunder, due and payable by the

Concessionaire within 20 Business Days after written demand by the University. The Concessionaire may contest any Taxes for which it is responsible pursuant to this Section 3.8 provided that (i) no such contest may involve a reasonable possibility of forfeiture or sale of the Utility System, and (ii) upon the final determination of any such contest, if the Concessionaire has not already done so, the Concessionaire shall pay any amount found to be due, together with any costs, penalties and interest. The University shall, at no out-of-pocket cost to the University, reasonably cooperate with the Concessionaire in any reasonable attempt by the Concessionaire to reduce or eliminate the Concessionaire's Tax liability.

Section 3.9. Utilities.

- (a) *Charges.* Unless otherwise directed by the University in writing, the Concessionaire shall ensure that contracts for utilities (other than those utilities that constitute Supplies, which is addressed in Section 7.3(d)) provide that invoices for all charges (including all applicable Taxes and fees) for such utilities and services used in the Utility System Operations during the Term are remitted to the Concessionaire, which the Concessionaire shall pay and shall be included as Capped O&M Costs. Upon request of the University, the Concessionaire shall forward to the University, within 15 Days following the respective due dates, official receipts, photocopies thereof or other evidence satisfactory to the University, of the payment required to be made by the Concessionaire in accordance with this Section 3.9. The University does not warrant that any utility services will be free from interruptions caused by war, insurrection, civil commotion, riots, acts of God, government action, terrorism, repairs, renewals, improvements, alterations, strikes, lockouts, picketing, whether legal or illegal, accidents, inability to obtain fuel or supplies or any other causes, and any such interruption of utility services in and of itself shall never be deemed an Adverse Action or an eviction or disturbance of the Concessionaire's use of the Utility System or any part thereof, or render the University liable to the Concessionaire for damages or, unless the same constitutes a Delay Event, relieve the Concessionaire from performance of the Concessionaire's obligations under this Agreement.
- (b) *Utility Coordination.* Subject to Section 7.3, the Concessionaire shall coordinate all Utility System Operations with utilities and Persons having service lines, pipelines, transmission lines and other equipment, cables, systems and other apparatus in, on, under, over, adjacent to or otherwise interconnecting with the Utility System. The Concessionaire shall notify the University in writing prior to communicating with any such utilities or Persons and shall take the University's direction in connection therewith, provided such direction is in accordance with Prudent Industry Practices and applicable Law. If the Concessionaire follows the direction of the University pursuant to the immediately preceding sentence, it shall be deemed to have satisfied its obligations with respect to this Section 3.9(b) solely with respect to the matter to which such direction by the University relates. In connection with its obligations under this Section 3.9(b), the Concessionaire shall cause provision to be made for the removal or temporary or permanent relocation and restoration of utilities

and other services and any lines, equipment, cables, systems and other apparatus not used in connection with Utility System Operations that intersect, interfere with, interface with or otherwise affect the Utility System Operations and shall arrange for temporary rights of entry and access to utilities and other services to be made available that are necessary in connection with the Utility System Operations or as may exist under this Agreement or applicable Law; provided that the University shall cooperate with the Concessionaire with respect to the Concessionaire's obligations under this Section 3.9(b).

- (c) *No Interference.* The Parties understand and agree that nothing in Section 3.9(b) is in any way intended to interfere with the Utility System Operations by the Concessionaire, and the University shall cooperate with the Concessionaire in minimizing any effect that the obligations of the Concessionaire under Section 3.9(b) and this Section 3.9(c) may have on the Utility System Operations, including reasonable efforts to schedule any such works outside of the academic term or on weekends.
- (d) *Communications Systems.* To the extent that the Concessionaire utilizes or connects with the University's communications systems, the Concessionaire shall be responsible for the operation and maintenance of its telecommunications systems up until the point of connection with the University's system in accordance with the Performance Standards.

Section 3.10. Notices of Defaults and Claims.

- (a) *Notice by the Concessionaire.* The Concessionaire shall promptly give notice to the University (i) if the Concessionaire becomes aware that a Concessionaire Default has occurred under this Agreement (provided, however, that the failure to give such notice shall not constitute an independent Concessionaire Default) and (ii) of all material claims, proceedings, disputes (including labor disputes) or litigation in respect of the Concessionaire pertaining to the Utility System, the Utility System Operations or the University (whether or not such claim, proceeding or litigation is covered by insurance) of which the Concessionaire is aware (other than as a result of a notice to the Concessionaire from the University). The Concessionaire shall provide the University with all reasonable information requested by it from time to time concerning the status of such claims, proceedings or litigation.
- (b) *Notice by the University.* The University shall promptly give notice to the Concessionaire (i) if the University becomes aware that a University Default has occurred under this Agreement (provided, however, that the failure to give such notice shall not constitute an independent University Default) and (ii) of all material claims, proceedings, disputes (including labor disputes) or litigation in respect of the University pertaining to the Utility System, the Utility System Operations or the Concessionaire (whether or not such claim, proceeding or litigation is covered by insurance) of which the University is aware (other than as a result of a notice to the University from the Concessionaire). The

University shall provide the Concessionaire with all reasonable information requested by it from time to time concerning the status of such claims, proceedings or litigation.

Section 3.11. Assignment of Operating Agreements and Plans; Project Intellectual Property.

- (a) *Operating Agreements and Plans.* At the request of the University, the Concessionaire shall collaterally assign, to the extent reasonably practicable and subject to the terms and conditions herein, to the University, in form and substance satisfactory to the University, all of the right, title and interest of the Concessionaire in, to and under all or any of the Operating Agreements and all present and future specifications, plans, drawings, information and any other documentation (except Project Intellectual Property) in relation to the Utility System Operations regardless as to whether any of the foregoing involve proprietary information (collectively, the “Operating Agreements and Plans”) as collateral security to the University for the observance and performance by the Concessionaire of its covenants and obligations under this Agreement. The Concessionaire covenants that it shall cause all of the right, title and interest of the Concessionaire in, to and under all Operating Agreements and Plans entered into or created after the Time of Closing to be collaterally assignable and transferable to the University as provided in this Section 3.11(a). The University acknowledges and agrees that the Operating Agreements and Plans may also be assigned as security to a Leasehold Mortgagee and that each of the University and such Leasehold Mortgagee shall be entitled to use the Operating Agreements and Plans in enforcing their respective security interests as hereinafter provided. Without limiting the generality of the foregoing, the University shall be entitled to use the Operating Agreements and Plans in the event of, and as necessary to, remedy a Concessionaire Default under this Agreement for so long as such Concessionaire Default is continuing and has not been cured. Notwithstanding the foregoing, in the event that any such Leasehold Mortgagee has entered into possession or is diligently enforcing and continues to diligently enforce its security, whether by way of appointment of a receiver or manager, foreclosure or power of sale in accordance with Article 19 or otherwise, or has entered (or is in process to enter) into a New Agreement under Section 19.5 and is using the Operating Agreements and Plans in respect of the Utility System Operations, the University shall not be entitled to use the Operating Agreements and Plans in enforcing its security, it being acknowledged that any assignment of the Operating Agreements and Plans to a Leasehold Mortgagee shall have priority at all times (other than if the University is enforcing its rights to cure under Section 3.3(c)(i)(B) or, if the Leasehold Mortgagee’s extended cure period under Section 19.3, if any, has expired and the Leasehold Mortgagee has not commenced any action to effect a cure in accordance therewith, Section 16.1(b)(iii)) over any assignment of the Operating Agreements and Plans to the University. The Concessionaire shall promptly deliver to the University, at the sole cost and expense of the Concessionaire, forthwith after completion or execution and delivery, a copy of each item of the Operating Agreements and

Plans. The University agrees that (i) it shall bear all risks associated with the use of the Operating Agreements and Plans, (ii) it may not rely on the Operating Agreements and Plans, and (iii) under no circumstances will the Concessionaire be liable in any way with respect to the University's use of, or for any loss or damage of any kind incurred as a result of the use of, the Operating Agreements and Plans.

- (b) *Project Intellectual Property.* The University ~~shall have and~~ has and was granted by the Original Agreement, which grant is hereby ~~granted~~ confirmed, a nonexclusive, transferable, irrevocable, perpetual, fully paid up right and license to use, exploit, reproduce, modify, adapt, and disclose, and sublicense others to use, reproduce, modify, adapt, and disclose, the intellectual property (including business systems and patents) of the Concessionaire or the Operator solely used in connection with the Utility System (the "Project Intellectual Property"), subject to the following:
- (i) the University shall have the right to exercise such license only in connection with the Utility System and Utility System Operations;
 - (ii) the University shall have the right to exercise such license only at the following times: (A) from and after the expiration or earlier termination of the Term for any reason whatsoever; (B) during any time that the University is exercising its rights pursuant to Section 3.7(a)(ii) or Section 3.7(a)(iii); and (C) during any time that a receiver is appointed for the Concessionaire, or during any time that there is pending a voluntary or involuntary proceeding in bankruptcy in which the Concessionaire is the debtor;
 - (iii) the University shall not at any time use, reproduce, modify, adapt and disclose, or allow any party to use, reproduce, modify, adapt and disclose, any such Project Intellectual Property for any other purpose;
 - (iv) the right to transfer the license is limited to any Person that succeeds to the power and authority of the University generally or with respect to the Utility System, and all such transfers shall be subject to Section 3.11(b)(v);
 - (v) the right to sublicense is limited to concessionaires, contractors, subcontractors, employees, attorneys, consultants, and agents that are retained by or on behalf of the University in connection with the Utility System, and all such sublicenses shall be subject to Section 3.11(b)(v); and
 - (vi) except to the extent required by Law, the University (A) shall not disclose any Project Intellectual Property to any Person other than authorized transferees and sublicensees who agree to be bound by any confidentiality obligations of the University relating thereto; (B) shall enter into a

commercially reasonable confidentiality agreement if requested by the Concessionaire with respect to the licensed Project Intellectual Property; and (C) include, or where applicable require the contract with the transferee or sublicensee to include, a covenant to employ sound business practices no less diligent than those used for its own confidential information, and no less diligent than required by commercially reasonable standards of confidentiality, to protect all Project Intellectual Property of the Concessionaire and other materials provided under the license or sublicense, as the case may be, against disclosure to third parties not in receipt of a license or sublicense, as applicable, and to use the license or sublicense only for the permitted purposes.

provided that: (A) for the avoidance of doubt, the Concessionaire shall continue to have a full and complete right to use any and all duplicates or other originals of its Project Intellectual Property in any manner it chooses, and (B) the University agrees that if it uses any Project Intellectual Property: (x) it shall bear all risks associated with the use of the Project Intellectual Property, (y) it may not rely on the Project Intellectual Property, and (z) under no circumstances will the Concessionaire be liable in any way with respect to the University's use of, or for any loss or damage of any kind incurred as a result of the use of, the Project Intellectual Property.

Section 3.12. Use of Information and Records.

- (a) Unless prohibited by applicable Law and to the extent reasonably necessary, the University shall be entitled to access all reasonable records, electronic data and other information collected and retained by the Concessionaire with respect to the Utility System and the Utility System Operations, including utility usage data, consumption pattern information and other utility data, and the Concessionaire shall maintain such records, data and other information in a format that is readily accessible to the University in order to facilitate the University's efforts with respect to energy efficiency, sustainability, environmental impact and research. The University shall use commercially reasonable efforts to provide at least 2 Business Days' written notice prior to accessing such records. At least 30 Days prior to the Closing Date, the Concessionaire shall deliver to the University for its Approval a proposed policy for the maintenance and retention of all records related to the operation and maintenance of the Utility System (once Approved, the "Record Retention Policy"). If the University does not Approve the Record Retention Policy, it shall provide the Concessionaire a reasonably detailed explanation for its disapproval, and the Concessionaire shall, promptly thereafter, submit a revised Record Retention Policy intended to address the University's comments, and this process shall continue until the University Approves a Record Retention Policy. [The University Approved the Record Retention Policy on December 30, 2020.](#) Following the Approval of the Record Retention Policy, the Concessionaire did and shall maintain all records related to the operation and maintenance of the Utility System in accordance with such Record Retention Policy. The University

covenants and agrees that it will implement safeguards to protect against the disclosure or misuse of any such Concessionaire information that is in its care or custody and will promptly inform the Concessionaire if there is any breach or suspected breach of security related to such information, subject to Section 8.2(b).

- (b) Unless prohibited by applicable Law, the Concessionaire shall be entitled to access all reasonable records, electronic data and other information collected and retained by the University to the extent reasonably required for, and only for the purpose of, the Concessionaire's performance of its obligations under this Agreement and the Performance Standards, including the maintenance of any Authorization. The University shall promptly make such records, data and information available to the Concessionaire as reasonably requested by the Concessionaire. Unless disclosure is required by applicable Law, the Concessionaire shall keep confidential any information obtained from the University or its Representatives, including any information obtained through its performance of the Utility System Operations. The Concessionaire covenants and agrees that it will implement safeguards to protect against the disclosure or misuse of any such University information that is in its care or custody and will promptly inform the University if there is any breach or suspected breach of security related to such information. If any information obtained from the University or its Representatives is provided by the Concessionaire, or the University on behalf of the Concessionaire, to any third party, including any equity member of the Concessionaire, the Operator or any Contractor, then (i) the Concessionaire shall cause such third party to comply with the provisions of this Section 3.12(b) and (ii) the Concessionaire shall be liable for the disclosure or use of such information by such third party as if the Concessionaire had disclosed or used it.

Section 3.13. Standard of Operation and Maintenance of the Utility System; Warranty Period Utility System Projects. At all times during the Term, the Concessionaire shall be required to maintain and operate the Utility System in accordance with the Performance Standards and Prudent Industry Practices. In the event any maintenance, repair or replacement is required in respect of any Warranty Period Utility System Project, other than in connection with an Emergency (in which case, only to the extent of such Emergency), the Concessionaire shall consult with the University prior to undertaking any such maintenance or repair. If such maintenance, repair or replacement could be covered by the warranty provided by the contractor that completed such Warranty Period Utility System Project, as determined by the University acting in good faith, then the University shall make a warranty claim to the contractor providing such warranty and shall use commercially reasonable efforts to pursue such claim and cause the contractor providing such warranty to perform such maintenance, repair or replacement pursuant to such warranty, provided that if the University is unsuccessful in causing such contractor to do so, then the Concessionaire shall perform such maintenance, repair or replacement. The foregoing obligation shall expire for each Warranty Period Utility System Project contemporaneously with the expiration of the applicable warranty period from such contractor, and the University shall provide notice to the Concessionaire of such expiration. Any Ongoing Utility System Projects that remain under warranty following their completion by the University

and delivery to the Concessionaire shall be treated as Warranty Period Utility System Projects until the expiration of the applicable warranty period for such Ongoing Utility System Project.

Section 3.14. Payments by the University. The Concessionaire acknowledges and agrees that if the University is required under applicable Law of general application to withhold a portion of any payment that the University is obligated to make to the Concessionaire under this Agreement and to pay such amount to a Governmental Authority, the University will be deemed to have satisfied such payment obligation to the Concessionaire to the extent of such withholding by the University and payment to the appropriate Governmental Authority. If any such withheld amounts are permitted to be paid to the Concessionaire, the University shall pay such amounts to the Concessionaire whenever permitted by Law. Any items and payment amounts that, to the Actual Knowledge of the University 10 Business Days prior to the Closing Date, it is legally required to withhold from the Concessionaire as of the Closing Date will be listed in Schedule 14 and agreed to by the Concessionaire, acting reasonably, prior to Closing as a condition of Closing, provided that regardless of whether any payment is listed on Schedule 14, the University shall always have the right to withhold payments pursuant to this Section 3.14 if required by Law and shall not be in breach of this Agreement. Prior to withholding any portion of any payment hereunder, the University shall give reasonable prior notice to the Concessionaire of the proposed withholding, and the Concessionaire shall promptly notify the University of any challenge by the Concessionaire to such proposed withholding. For the avoidance of doubt, any payment obligation of a University's department, office or center required by this Agreement is a payment obligation of the University for purposes of this Agreement, and the University shall either cause such department, officer or center to pay the payment obligation or shall satisfy the payment obligation itself.

Section 3.15. Naming and Signage Rights, Other Revenue Activities and Commercial Advertisements and Activities.~~—~~—

- (a) Due to the importance of having uniform signage on the University Campus for safety and aesthetic purposes, the Concessionaire shall have no right to name or modify the name of the Utility System or any portion thereof or, unless required to do so by applicable Law, to install signage of any kind thereon, without the University's Approval, which may be withheld in its discretion.
- (b) The University shall have the right, in its discretion, to install, replace, display and maintain signage (i) that relates to identification or naming of the Utility System, the Utility Facilities, portions thereof, or surrounding areas or (ii) for informational or educational purposes; provided that (A) the Concessionaire shall have no obligation under the Performance Standards to replace or maintain any signage installed by the University for advertising purposes, and (B) the University shall not install any signage that relates to naming of the Utility System, the Utility Facilities, portions thereof, or surrounding areas for a Person that competes directly with the Concessionaire or the Operator.
- (c) The Concessionaire shall be entitled to develop additional sources of revenue in connection with the Utility System, including providing utility services to customers other than the University and making market-based sales of electricity

if the University Approves such activities and the Concessionaire shall be liable to the University for, and reimburse the University for, any Losses incurred by the University as a result thereof, including any increase or additional Property Taxes imposed upon the University or the Utility System, the cost of which may not be included in any component of the Utility Fee, provided that the University's Approval shall not be required to explore and investigate such additional sources of revenue so long as the Concessionaire does not implement such additional sources of revenue and the Concessionaire is liable for any Losses to the University as a result of such exploration and investigation. To the extent possible, the Concessionaire shall pay any increased or additional Property Taxes resulting from such additional sources of revenue directly to the applicable Governmental Authority.

- (d) Notwithstanding anything to the contrary contained herein, due to the importance to the University of having uniform nutritional choices on the University Campus, the University hereby reserves the right to install and operate vending machines in any portion of the Utility System and to access the Utility System for the purposes thereof, and the University shall be entitled to the revenue generated by such vending machines.
- (e) The University and the Concessionaire agree that they shall execute on Closing a trademark license agreement in the form attached hereto as Schedule 20.

Section 3.16. Reversion of Utility System. On the Reversion Date, the Concessionaire shall surrender and deliver to the University all of its rights, title and interest in the Utility System (including all improvements to the Utility System, the Utility System Assets and all tangible and intangible personal property of the Concessionaire (including inventories) that is included in the Utility System and used in connection with the Utility System Operations) subject, however, as to any intellectual property included in the Utility System, to any restrictions or prohibitions to disclosure, transfer or sharing thereof and any other rights of third parties with respect thereto, all in accordance with the provisions of Section 16.3. With respect to any third party or proprietary software utilized by the Concessionaire in the operation of the metered Utility System at the time of the Reversion Date, the Concessionaire and the University will negotiate in good faith appropriate license rights and terms for the University's continued use of the software following reversion.

Section 3.17. Police, Fire, Emergency and Public Safety Access Rights. Notwithstanding any other provision of this Agreement, at all times during the Term and without notice or compensation to the Concessionaire: (i) any police, fire and emergency services and any other security or emergency personnel retained by or on behalf of the University shall have access, as required by such services or personnel, to the Utility System; (ii) the University shall have access to the Utility System as necessary for the protection of public safety; and (iii) any Governmental Authority with jurisdiction over the Utility System shall have access to the Utility System as necessary for inspection, emergency management and homeland security purposes, including the prevention of or response to a public safety emergency (so long as any exercise of

such jurisdiction, to the extent effected by the University, shall be strictly in accordance with the terms hereof).

Section 3.18. Negotiations with Third Parties. Prior to entering into any agreement with any third party, including any Governmental Authority, in connection with the Utility System Operations (a “Third Party Agreement”) that extends or could extend beyond the Term or pursuant to which the University may incur any liability whatsoever thereunder, the Concessionaire shall submit such Third Party Agreement for Approval by the University (which Approval may be withheld, conditioned, or delayed in the discretion of the University) prior to the execution and delivery thereof (except with respect to Third Party Agreements the absence of which may cause the Concessionaire or Utility System Operations to fail to be in compliance with applicable Law or this Agreement, in which case the Concessionaire may enter into such Third Party Agreement upon notice to the University provided that the Concessionaire indemnifies the University for any Losses relating thereto).

Section 3.19. Administration of the Public Way. The Concessionaire acknowledges and accepts that the University holds and administers the Public Way for the non-discriminatory benefit of all Persons and interests, including the Concessionaire and the Concessionaire Interest. The rights granted to the Concessionaire under this Agreement do not create a priority in favor of the Concessionaire over any other user of the Public Way, and such rights are subject to the Performance Standards and all provisions of Law.

Section 3.20. Rights to Adjacent Space. The University hereby reserves, and is not demising or leasing to the Concessionaire, the right or easement to construct and reconstruct and forever maintain the air rights with respect to the Utility Facilities and other property within the Utility System and the right to construct, use or occupy any of the space not directly occupied by the Utility System, including (i) any and all space located above, below or adjacent to any such property, and (ii) any and all space located above, below or adjacent to any improvements within the Utility System as of the ~~date hereof~~Signing Date, provided that such construction, use or occupancy does not materially impair the Utility System Operations. For the avoidance of doubt, to the extent that any Utility Facility is buried below the surface of any part of the University Campus, the University shall have the right to construct any building, structure or other improvement on that part of the University Campus, provided such construction does not damage or alter such buried Utility Facilities. The University’s exercise of its rights hereunder shall not be subject to any of the terms and conditions of Section 3.7(a).

Section 3.21. Sole Utility Provider. The University covenants that, during the Term, it will not, and it will not contract or agree with any third party to, provide any Utility or Utility Services on the University Campus, except in the following circumstances: (i) as of the Bid Date, a third party is providing the relevant Utility or Utility Services to a portion of the University Campus, in which case the University may continue to have that third party or a successor thereto or a replacement thereof provide such Utility or Utility Services during the Term on only that portion of the University Campus ~~or~~; (ii) as of the Bid Date, any district utility systems within the University Campus which are generating or distributing Utilities beyond the lines of demarcation identified in the Performance Standards ~~or~~; (iii) the University installs systems, equipment or materials for the distribution of Utilities beyond the lines of demarcation identified in the Performance Standards, which shall be performed by or on behalf of the

University; or (iv) as otherwise expressly set forth herein, and, if the University breaches such covenant, it shall be a Compensation Event as the Concessionaire's sole remedy pursuant to the definition of Compensation Event. For the avoidance of doubt, if the University does not own or lease a building, facility, other improvement or land within the University Campus, the University shall have no obligation with respect to causing the Concessionaire to be the sole provider of Utilities or Utility Services with respect to such building, facility, other improvement or land, and there shall be no Concession Compensation payable in connection therewith, except as expressly set forth in Section 5.3.

Section 3.22. Repair and Maintenance of the Tunnels. The Concessionaire covenants that, during the Term, it shall be responsible for maintaining, repairing and replacing the Tunnels, which, for the avoidance of doubt, are part of the Utility System, including the right to include New Approved Capital Improvement Costs for Capital Improvements with respect to the Tunnels (if Approved in accordance with Article 4) in the calculation of the Variable Fee Component and the Capital Recovery Amount. The Concessionaire or the Operator shall contract with a Contractor to perform such restoration, repair or maintenance, which Contractor must either be on a list of pre-approved contractors provided by the University or otherwise Approved by the University in its discretion. If the Concessionaire fails to repair and maintain the Tunnels in accordance with Prudent Industry Practices and such failure creates an Emergency, the University shall have the right to take such action as is necessary to remedy such Emergency, and the Concessionaire shall, within 30 Days after receipt of an invoice therefor, reimburse the University for the out-of-pocket cost thereof, provided that the University shall, where practical, provide the Concessionaire advance written notice of such action. Notwithstanding the foregoing, the Concessionaire shall not interfere with, modify or alter any of the personal property, fixtures or improvements within the Tunnels that are not used in Utility System Operations, and the University shall have the right to access the Tunnels, not subject to Section 3.7, to maintain, alter, improve, repair or remove any such personal property, fixtures or improvements, provided, the University shall use commercially reasonable efforts to minimize interference with Utility System Operations.

Section 3.23. Adjustments to the Location or Configuration of the Utility System. The University shall have the right, upon notice to the Concessionaire, to cause the Concessionaire to alter the location or configuration of the Utility System or to designate alternative real property for the Utility System Land to the extent the University deems it necessary or useful in the operation and use of the University Campus, including in connection with the reconstruction of a Utility Facility following a fire or other casualty. Except as provided in Section 13.4 with respect to any modifications in connection with a casualty, to the extent such alteration or designation of alternative real property is a Capital Improvement, it shall be considered a New Approved Capital Improvement for a budgeted cost and an increase in the Capped O&M Index reasonably approved by the Concessionaire and the University, but, to the extent such alteration or designation of alternative real property is not a Capital Improvement, the costs incurred by the Concessionaire or the Operator as a result of the University's exercise of its right under this Section 3.23 shall be considered an Uncapped O&M Cost in accordance with the definition thereof. If the University directs the Concessionaire to relocate the Utility System to a location to which it does not have a right to access pursuant to this Agreement, the University shall grant occupancy rights to the Concessionaire sufficient for the Concessionaire to meet its obligations hereunder. If the University designates alternative

real property for the Utility System Land, then, upon such designation, (i) such alternative real property shall be deemed Utility System Land for purposes of this Agreement, (ii) the Concessionaire shall return the prior Utility System Land and all improvements and Utility Facilities thereon to the University in the condition required under Section 16.3, at no additional cost to the University, other than out-of-pocket costs incurred by the Concessionaire in connection with such transfer (including the cost of recording the conveyance documentation and the cost of a title policy for the alternative real property for the Utility System Land in the event that the Concessionaire received a title policy with respect to the original Utility System Land), and (iii) in accordance with the University's designation of alternative real property, the Concessionaire shall relocate the Utility Facilities then existing on the prior Utility System Land to the alternative real property. The Concessionaire shall have the right to amend the Memorandum of Lease to reflect any changes resulting from the University's exercise of its right under this Section 3.23, and the University shall reasonably cooperate in such amendment and shall pay the out-of-pocket costs incurred by the Concessionaire in connection therewith.

Section 3.24. Sales to Individual Customers on the University Campus. The Concessionaire shall not be permitted to sell any fuels or Supplies to individual customers on the University Campus. To the extent that the Concessionaire supplies fuels or Supplies to the University for distribution to individual customers, the University shall control the distribution of such fuels or Supplies. The Concessionaire shall have no interests or rights to charge or collect any payments from the University or such individual customers for the provision of such fuels or Supplies.

Section 3.25. University Business Continuity Plan. The Concessionaire shall reasonably cooperate with the University in connection with the University's business continuity plan and shall attend any University meetings regarding such plan if requested by the University.

Section 3.26. Utility System Tours. The Concessionaire shall provide tours of the Utility System or any portion thereof to the University and its Representatives upon reasonable request by the University, provided that (i) the Concessionaire shall have the right to refuse to give any tour if such tour would unreasonably interfere with the operation of the Utility System or any of the Concessionaire's other obligations hereunder and (ii) all tour participants shall be required to comply with the Concessionaire's reasonable safety protocols and requirements to the extent provided in writing to the University.

Section 3.27. Uniforms. To aid the University's provision of security and safety measures to the University Campus, Concessionaire and Operator personnel working on the University Campus shall wear a uniform (and other insignia) that is standard across the Utility System and clearly identifies such personnel as Concessionaire and Operator personnel and not employees of the University.

Section 3.28. EAC. The Parties acknowledge the importance of documenting and discussing best practices and Prudent Industry Practices for Comparable Utility Systems to determine whether the Parties should consider modifying the Performance Standards, Key Performance Indicators or the components of the Utility Fee or should consider providing incentives to the Concessionaire to meet certain operational targets. In connection therewith, the University shall form an EAC to liaise with the Concessionaire so that the University and the

Concessionaire have an open dialogue with respect to such matters. The EAC shall meet, which meetings may be held telephonically, as reasonably necessary to address issues that arise during the Term, as determined by the University.

Section 3.29. Sustainability. The Concessionaire acknowledges that the University has a long-term commitment to operating the University Campus in a sustainable manner and that the Utility System Operations are an integral part of that commitment. As such, consistent with Prudent Industry Practices and subject to obtaining any required University Approvals for Capital Improvements and Material Changes, the Concessionaire agrees that, in connection with the Utility System Operations, it will reasonably cooperate with the University to operate the Utility System in a manner consistent with the University's larger goal to promote a sustainable campus and to acknowledge stewardship of the natural environment and resources by the University and its stakeholders. The Concessionaire will use commercially reasonable efforts to implement any changes to the Utility System Operations requested by the University in the form of a University Directive to increase the sustainability of the Utility System Operations that do not materially and adversely affect the Concessionaire's ability to meet its obligations hereunder, including the obligation to meet the Performance Standards. In addition, the Concessionaire will use commercially reasonable efforts throughout the Term to propose Capital Improvements and Material Changes pursuant to Article 4 that are reasonably intended to increase the sustainability of the Utility System Operations and the University Campus, including reduction of emissions, Utility use and other impacts on the environment. Further, the Concessionaire shall attend any University meetings regarding sustainability planning on the University Campus if requested by the University. Further, the Parties acknowledge that what constitutes "sustainability" may evolve over the Term and that the Parties intend that, for purposes of this Section 3.29, "sustainable" and "sustainability" shall have the then-current generally accepted utility industry meaning of the term, which, as of the ~~date of this Agreement~~Signing Date, includes undertaking measures to (i) reduce energy and water consumption, (ii) become a net-negative energy use, (iii) reduce the impact of operations on the environment, (iv) recycle and reuse resources, (v) purchase goods and services derived in a sustainable manner and (vi) employ goods and services that protect the environment. For the avoidance of doubt, the Concessionaire shall not be required to incur costs that would otherwise be Capped O&M Costs or Uncapped O&M Costs to comply with this Section 3.29 unless such costs are included in an Approved Five-Year Plan.

Section 3.30. University Utility System Employees. During the Term, the Concessionaire shall, or shall cause the Operator to, maintain a program for the employment of students of the University in connection with the Utility System Operations, which shall be on terms and conditions determined by the Concessionaire or Operator, as applicable. Further, the Concessionaire shall, or shall cause the Operator or their Affiliates to, develop and maintain an internship program for University students to gain hands-on, practical experience with structured educational and mentorship opportunities either with respect to the Utility System or other utility systems owned, leased, operated or maintained by the Concessionaire, the Operator or any of their Affiliates. In addition, the Concessionaire shall, or shall cause the Operator to, maintain a program for employment of apprentices serving industrial and skilled trades of boiler makers and water purveyors in connection with the Utility System Operations, which shall be on such reasonable terms and conditions as determined by the Concessionaire or Operator, as applicable. Further, the Concessionaire shall, or shall cause the Operator and their Affiliates to, develop experience with structured educational and mentorship opportunities either with respect to the

Utility System or other utility systems owned, lease, operated or maintained by the Concessionaire, the Operator or any of their Affiliates.

Section 3.31. Office Space. To the extent requested by the Concessionaire in writing, the Parties shall use reasonable efforts to enter into a commercially reasonable license agreement with respect to the temporary license of office space (not to exceed 1,000 square feet) by the University to the Concessionaire within a location on the University Campus at no additional cost. The University shall not be required to provide such space if it determines, in its sole discretion, that it does not wish to provide such space based on its current use, and it may terminate such license or may cause such licensed space to be moved to a new location at any time upon Notice to the Concessionaire and may require the Concessionaire to abide by reasonable rules and regulations, including limiting the hours of access thereto.

Section 3.32. Utility System Space in Larger Buildings. The Concessionaire acknowledges that each of McClure Hall Space, Transformer Storage Space and Vehicle Research Lab Space (the “Shared Spaces”) are not separate buildings but are spaces within larger buildings that the University owns. As such, the University shall retain the responsibility, either by University employees or Contractors at the University’s direction, to maintain, repair, replace and keep in good order and condition the structural and building-system components of the buildings in which the Shared Spaces are located, including the roof, load-bearing walls and foundation of each of the foregoing, except to the extent any maintenance, repair or replacement is caused by the negligence or willful misconduct of, or violation of applicable Law by, the Concessionaire or its Representatives, in which case the Concessionaire shall be responsible therefor and shall perform such maintenance, repair or replacement as promptly as reasonably practicable. Subject to the University’s rights under Section 3.23, if a building in which a Shared Space is located is damaged by a fire or other casualty of any kind or nature, then the University shall restore such building to the condition in which it existed prior to such fire or other casualty but shall not, for the avoidance of doubt, be responsible for repairing or restoring the furniture, fixtures or equipment within the Shared Space that are part of the Utility System. The Concessionaire shall abide by any reasonable rules and regulations promulgated by the University and provided to the Concessionaire in writing with respect to the buildings in which the Shared Spaces are located, and the Concessionaire shall have non-exclusive access to any common areas of the larger buildings (as identified by the University) in which those Shared Spaces are a part. The Concessionaire shall not be obligated to pay any additional rent with respect to the Shared Spaces.

ARTICLE 4 CAPITAL IMPROVEMENTS AND MATERIAL CHANGES

Section 4.1. Concessionaire Responsibility for Capital Improvements. Other than the Ongoing Utility System Projects or as otherwise expressly set forth herein, the Concessionaire shall be responsible for all Capital Improvements with respect to the Utility System required to be completed during the Term in accordance with the terms of this Agreement, including as required by the Performance Standards ~~;~~ provided, however, that the University reserves the right to procure the design, construction and putting into service of Capital Improvements to the Utility System from any Person other than the Concessionaire by competitive bid through the State of Idaho Department of Administration, Division of Public

Works or otherwise (each a “Third Party Capital Improvement”) upon the satisfaction of the following conditions:

- (a) The State of Idaho or the U.S. federal government makes a special allocation of funds (“Special Allocation of Funds”) for capital improvements to infrastructure for which the Utility System is eligible. For the purposes of this section, a Special Allocation of Funds shall refer to an appropriation which is (i) focused specifically upon capital improvements to infrastructure, (ii) exceeds \$10,000,000 (Adjusted for Inflation starting with the Year 2024) in aggregate and (iii) at least two hundred percent (200%) greater than any Special Allocation of Funds in the preceding Fiscal Year;
- (b) A Capital Improvement executed and financed by the Concessionaire in accordance with this Agreement would not be eligible to be funded by the Special Allocation of Funds;
- (c) The University has approved Capital Improvements proposed by the Concessionaire with an average value on an annual basis in excess of \$8,000,000 (Adjusted for Inflation starting with the Year 2024) for the three Fiscal Years preceding the Fiscal Year in which a Third-Party Capital Improvement is to be executed;
- (d) The University has not previously Approved additional work in relation to such Capital Improvement pursuant to Section 4.3(c)(ii); and
- (e) A Special Allocation of Funds funds one hundred percent (100%) of the total capital cost of such Capital Improvement.

Furthermore, to the extent allowed by Law and subject to any conditions imposed by the funding source on the use of the relevant capital outlay funds, (A) the Concessionaire shall be allowed to participate in the procurement and delivery process (including drafting performance specifications and oversight of project delivery) for such Capital Improvements, and (B) to the extent reasonably practicable, as part of such competitive bid or other public procurement process, the Parties shall endeavor to procure Utility-related equipment of such brands, models or types that will ensure system compatibility and maximize future repair and maintenance efficiencies (provided that there shall be no exclusivity with respect to the procurement of Utility-related equipment) and any party other than the Concessionaire or the Operator who executes such Capital Improvement shall be required to provide a two-Year warranty on all material and workmanship, provided that if such warranty is for less than two Years, the University shall reimburse the Concessionaire for any costs after the expiration of such warranty and before the expiration of two Years after substantial completion of the applicable Capital Improvement that would have otherwise been covered by such warranty as Uncapped O&M Costs. If a Capital Improvement is performed by a third-party pursuant to this Section 4.1, then if a defect in such Capital Improvement is identified within the two (2) year period after its substantial completion, then such defect shall be a Delay Event but only for such period as such Capital Improvement is not in service while such defect is being corrected, provided that the Concessionaire shall, as soon as reasonably practicable, cause such defect to be corrected

pursuant to the warranty provided by the Contractor or by the University in accordance with the immediately prior sentence. In the event that University procures a Capital Improvement from any Person other than the Concessionaire pursuant to a competitive bid or other public procurement process, as provided in this Section 4.1, then the University shall pay the Concessionaire a development fee equal to ten percent (10%) of the total capital costs of such Capital Improvement that were funded by such capital outlay upon the substantial completion thereof, as determined by the project architect. For the avoidance of doubt, such development fee shall be paid outside of and not as a component of the Utility Fee.

Section 4.2. Authorizations Related to Capital Improvements. The Concessionaire's obligation to perform Capital Improvements shall be subject to the issuance by Governmental Authorities and the University of any and all Authorizations required to be issued by such parties with respect thereto, and the University agrees (i) not to unreasonably withhold, condition or delay the issuance of any Authorization to be issued by the University for an Approved Capital Improvement and (ii) to use its reasonable efforts to assist the Concessionaire in obtaining any Authorizations required to be issued by Governmental Authorities, provided that the Concessionaire shall reimburse the University in a timely manner for any reasonable out-of-pocket costs incurred by the University in providing such assistance. Without limiting the generality of the foregoing, the University agrees that it will reasonably assist and cooperate with the Concessionaire in obtaining any and all Authorizations (including any required rights of access over real property that is owned or controlled by the University) in order for the Concessionaire to perform an Approved Capital Improvement, which assistance shall include providing the Concessionaire reasonable access to the areas of the University Campus where the Approved Capital Improvement will be located, subject to the reasonable conditions and restrictions of the University, provided that the Concessionaire shall reimburse the University in a timely manner for any reasonable out-of-pocket costs incurred by the University in providing such assistance.

Section 4.3. Approval of Capital Improvements and Material Changes.

- (a) The Concessionaire shall not have the right to make any (i) Capital Improvements or (ii) Material Changes, except those Capital Improvements or Material Changes which are Approved pursuant to Section 4.3(c).
- (b) The Concessionaire shall have the right to request Approval of (I) a proposed Capital Improvement or Material Change or (II) a change in the scope or cost of a previously Approved Capital Improvement or Material Change at any time (and shall identify whether an item requested for Approval or any portion thereof is a Capital Improvement or Material Change or a combination thereof), but the University shall not be obligated to consider any such requests for Approval except those requests (i) (A) contained in a proposed Five-Year Plan submitted in accordance with Section 7.2 and (B) proposed to be commenced in the first full Fiscal Year in such proposed Five-Year Plan; (ii) required to address an Emergency, a change in Law or a change in a Performance Standard; (iii) required in connection with a University Directive; or (iv) required due to Force Majeure, all of which the University shall consider in good faith.

- (c) The Concessionaire shall request Approval of one or more proposed Capital Improvements or Material Changes or Approval of a proposed change in the scope or cost of a previously Approved Capital Improvement or Material Change by (1) submitting a request to the University, or an office or person designated by the University Liaison, containing a detailed description of each proposed Capital Improvement or Material Change or proposed change in the scope or cost of a previously Approved Capital Improvement or Material Change or (2) submitting a proposed Five-Year Plan in accordance with Section 7.2 containing a detailed description of each proposed Capital Improvement or Material Change proposed to be commenced in the first full Fiscal Year in such proposed Five-Year Plan or each proposed change in the scope or cost of a previously Approved Capital Improvement or Material Change, provided that, in each case, such detailed description shall include: (A) total costs for construction and installation thereof, including all hard and soft costs, ~~any financing costs~~ and any applicable sales or use tax; (B) forecasted annual operations and maintenance costs therefor; (C) any proposed modification to the Recovery Period (if applicable) for such Capital Improvement; (D) an explanation of all relevant assumptions, variables, and data sources, used to develop the proposal; (E) the proposed schedules, process, and other technical and logistics details associated with the proposed Capital Improvement and/or Material Change proposal, including any liquidated damages if the Concessionaire fails to meet the proposed schedule; (F) how such proposed Capital Improvement and/or Material Change will improve the sustainability of the Utility System Operations or the University Campus; (G) any actual or anticipated tax credits or other benefits that will accrue to the Concessionaire as a result thereof of which the Concessionaire has knowledge, and a description thereof as well as a description as to how such credits or benefits will be incorporated into the Capital Improvement Cost (if Approved); (H) any fee or charge payable to the Operator in connection with such Capital Improvement or Material Change; (I) any proposed change to the limits on the professional liability insurance coverage for the professionals providing services with respect to such Capital Improvement or Material Change and the associated change in the premium associated therewith; and (J) any potential increase or reduction in Supply Costs or consumption of Supplies that would result from such Capital Improvement or Material Change; provided that, (x) to the extent any of the details set out in clauses (A) through (J) above are unavailable or inapplicable, the Concessionaire shall describe the reason for such unavailability or inapplicability and (y) to the extent that the Concessionaire has explicitly requested that the University respond only pursuant to Sections 4.3(c)(ii), (iii) or (iv), the Concessionaire may include an indicative estimate or estimate range with respect to Sections 4.3(c)(A) or (B). To the extent the University elects to, or is required to, consider a request for Approval of a proposed Capital Improvement or Material Change or a change in the scope or cost of a previously Approved Capital Improvement or Material Change, the University shall review such request and, in its discretion:
- (i) Approve such request in accordance with the terms of such request after having undertaken all such necessary action and secured all

authorizations, consents and approvals required to be obtained by the University with respect to such Approval at such time, unless the Concessionaire's written request submitted to the University explicitly requested that the University respond only pursuant to Sections 4.3(c)(ii), (iii) or (iv); ~~or~~

- (ii) provide a written response requiring that the Concessionaire (1) perform additional work with respect to such proposed Capital Improvement or Material Change or proposed change in the scope or cost of a previously Approved Capital Improvement or Material Change to provide further information regarding the scope, design or cost thereof and/or multiple alternative designs therefor to the University, which additional work may include procuring design services or a quotation for a guaranteed maximum price or lump sum contract from a contractor or multiple contractors for the proposed Capital Improvement or Material Change or proposed change in the scope or cost of a previously Approved Capital Improvement or Material Change or procuring any details set out in clauses (A) through (I) of Section 4.3(c)(2) that were previously unavailable, provided that the cost of such additional work shall be subject to the University's prior Approval, and (2) after performing such additional work, submit a revised request for Approval by the University pursuant to this Section 4.3(c), which revised request, if the initial request was made in connection with the submission of a proposed Five-Year Plan, the University shall consider with respect to the same proposed Five-Year Plan, if submitted within 15 Days before the commencement of the first Fiscal Year of such Five-Year Plan; ~~or~~
- (iii) (1) provide the Concessionaire with comments on such proposed Capital Improvement or Material Change or proposed change in the scope or cost of a previously Approved Capital Improvement or Material Change, including comments on any details provided in the Concessionaire's proposal, which may include comments from the University intended to align the proposal with the larger University Campus capital improvement plans existing at such time or disagreeing with its characterization as a Capital Improvement or Material Change, and (2) require that the Concessionaire incorporate such comments and submit a revised request for Approval pursuant to this Section 4.3(c); provided that if the University elects to exercise its rights under this Section 4.3(c)(iii), then the Concessionaire shall have the right, upon written notice to the University, to withdraw its request for Approval; or
- (iv) (1) reject such proposed Capital Improvement or Material Change or proposed change in the scope or cost of a previously Approved Capital Improvement or Material Change and (2) if such proposed Capital Improvement or Material Change or change to the scope of a previously Approved Capital Improvement or Material Change is necessary to comply with Prudent Industry Practices, applicable Law, or the

Performance Standards, provide the Concessionaire with a reasonably detailed explanation for such rejection, provided that the University shall not be permitted to reject such proposal under this Section 4.3(c)(iv) if (w) such proposal is required to cause the Utility System to comply with any new Law or change in Law existing as of the Setting Date and the Concessionaire has received written notice from the applicable Governmental Authority that the Utility System is not in compliance therewith, (x) the Concessionaire has reasonably investigated any potential alternatives to such proposal and provided the University with reasonable evidence of such investigation, (y) the Concessionaire has discussed in good faith with the University and reasonably considered any potential viable alternatives to such proposal and (z) the University has provided no reasonable alternative that would address such new or changed Law, as applicable, that the University has confirmed that it would Approve.

Notwithstanding anything to the contrary in the foregoing, if a single request for Approval pursuant to this Section 4.3(c) includes multiple discrete proposed Capital Improvements or Material Changes or changes in the scope or cost of a previously Approved Capital Improvement or Material Change, the University shall have the right to provide different responses with respect to each proposal included in such request.

- (d) To the extent that the Concessionaire elects to abandon a proposed Capital Improvement or Material Change after it has been Approved by the University, which the Concessionaire may do so upon Notice to the University, unless such Capital Improvement or Material Change is the subject of a University Directive, the Concessionaire shall be obligated to promptly restore the Utility System and any other affected area of the University Campus to the condition that existed prior to the commencement of such Capital Improvement or Material Change. As a condition of its Approval of any proposed Capital Improvement or Material Change or proposed change in the scope or cost of a previously Approved Capital Improvement or Material Change, the University may require certain payments of liquidated damages by the Concessionaire to the University if the Concessionaire does not meet the timeframe set forth in the applicable Approval regardless of the abandonment of such Capital Improvement or Material Change, but only to the extent such liquidated damages are proposed in the Concessionaire's most recent request for Approval thereof.
- (e) To the extent a proposed Capital Improvement or proposed change in a previously Approved scope or cost of a Capital Improvement is Approved, the Concessionaire shall have the right to (i) deem the cost of such Capital Improvement (up to the Approved amount) or the change in such cost (up to the Approved amount), as applicable, a New Approved Capital Improvement Cost in accordance with Schedule 5 and (ii) include the out-of-pocket costs incurred by the Concessionaire in connection with preparing and submitting a revised request for Approval of such Capital Improvement pursuant to Section 4.3(c)(ii)

(if applicable) as part of such New Approved Capital Improvement Cost. The Approved out-of-pocket costs incurred by the Concessionaire pursuant to Section 4.3(c)(ii)(1) in connection with a proposed Capital Improvement or a proposed change in the scope or cost of a previously Approved Capital Improvement that is not Approved shall be included in Uncapped O&M Costs. For any proposed Material Change that is not a Capital Improvement or any proposed change in the scope or cost of a previously Approved Material Change, the out-of-pocket costs incurred by the Concessionaire pursuant to Section 4.3(c)(ii) shall be included in Uncapped O&M Costs.

- (f) After Approval of a proposed Capital Improvement or Material Change or a proposed change in the scope or cost of a previously Approved Capital Improvement or Material Change, the Concessionaire shall make such Capital Improvement or Material Change in accordance with this Agreement, but subject to Section 4.3(d).
- (g) Notwithstanding anything to the contrary contained in this Section 4.3, to the extent that the Concessionaire incurs any out-of-pocket costs as O&M Costs, it shall have the right to request that the University Approve those costs as a Capital Improvement and that those costs be considered as such, and such request shall be considered a request for Approval of a proposed Capital Improvement.
- (h) In the event that the cost of any Approved Capital Improvement or Material Change is less than \$100,000 (Adjusted for Inflation starting from the Year in which the Closing occurred), such costs will be classified as Uncapped O&M Costs for purposes of calculating the Utility Fee, unless otherwise indicated by the University, in its discretion, in its Approval thereof.

Section 4.4. University's Capital Plan. The Concessionaire shall reasonably cooperate with the University in the development, modification, and discussion of the University's capital plans and energy conservation initiatives, including participating with the University's capital planning and capital plan forecasting processes, attending planning meetings, and, as requested by the University, attending and participating in University meetings related to the University's capital plans.

ARTICLE 5 MODIFICATIONS

Section 5.1. University Directives. The University may, at any time during the Term, issue a University Directive to the Concessionaire, which may include (i) the construction of Capital Improvements and the addition to or removal from the Utility System of buildings or other improvements owned, leased or operated by the University or its Affiliates or (ii) the design, demolition, project management, construction, repair, replacement, remodeling, renovation, reconstruction, enlargement, addition, alteration, painting, or structural or other improvements not included in the Utility Facilities but related thereto. No University Directive shall have the effect of reducing the components of the Variable Fee Component or Fixed Fee.

Subject to the Concessionaire having obtained (with the cooperation of the University) all relevant Authorizations from all relevant Governmental Authorities required for the relevant work, the Concessionaire shall perform the work required to implement such University Directive. Utility Facilities constructed as the result of a University Directive shall be (a) deemed to be part of the Utility System for purposes of this Agreement and (b) included in the Utility System to be operated by the Concessionaire under the terms of this Agreement. To the extent any University Directive requires the construction of a Capital Improvement, the cost of such Capital Improvement shall be included as a New Approved Capital Improvement Cost up to the Approved cost of such Capital Improvement set forth in the University Directive. To the extent any University Directive requires the construction of anything other than a Capital Improvement, the costs associated therewith shall be Uncapped O&M Costs in accordance with the definition thereof. In addition, with respect to any University Directive, the Concessionaire and the University shall determine in good faith the forecasted annual ongoing operations and maintenance costs associated with such University Directive (or any reductions in current annual ongoing operations and maintenance costs associated therewith), and the Capped O&M Index shall be increased or decreased by such amount. To the extent that that an order or directive would be a University Directive but for the operation of sub-paragraph (4)(y) of the definition of “University Directive”, and in the event that the Concessionaire notifies the University in writing that it is not willing to carry out such order or directive for such reason: (A) the University may elect to engage a third party to perform the relevant order or directive, and (B) if the University so elects, the University and the Concessionaire shall determine in good faith any corresponding adjustments to the Utility Fee and other provisions of the Concession Agreement that may be required to put the Parties in substantially the same economic position as they were prior to such actions being taken, provided the University shall not be required to compensate the Concessionaire for any benefit that the Concessionaire would have received if it undertook the University Directive.

Section 5.2. Performance of Modifications. Subject to the other provisions of this Article 5, the Concessionaire shall ensure that University Directives are performed in a good and professional manner and diligently complied with and implemented in accordance with Prudent Industry Practices.

Section 5.3. Addition, Removal and Lease of Property.

- (a) If, after the Closing Date, the University sells, conveys, leases for a period of time longer than the remaining Term or otherwise transfers ownership of any real property within the University Campus to a third party unaffiliated with the University, then, contemporaneously with such transfer, the Concessionaire shall disconnect such real property from the Utility System and remove or abandon in place all Utility Facilities and Utility System Assets thereon and shall not be permitted to serve such real property, except if Approved in accordance with Section 3.15(c). However, if the University elects to enter into a concession agreement, ground lease, management agreement or similar agreement with a third party to operate and maintain any real property that had been part of the University Campus, the Concessionaire shall not be required to disconnect such real property from the Utility System, provided that, for the avoidance of doubt, if any ground lease or similar lease agreement is for a period longer than the

remaining Term, then it shall be subject to the immediately preceding sentence such that the Concessionaire shall disconnect such real property from the Utility System in accordance therewith. If such disconnection causes a Capital Improvement that is or had been a New Approved Capital Improvement to be removed from the Utility System, the Capital Improvement shall continue to be included in the Variable Fee Component in accordance with this Agreement as if not removed from the Utility System. The Concessionaire shall reasonably cooperate with the University and the transferee of such real property in such disconnection. In connection therewith, the University and the Concessionaire shall cooperate in good faith to make any reasonably necessary adjustments to the Key Performance Indicators and the Performance Standards as a result of such sale, conveyance or lease.

- (b) Due to the fact that the Concessionaire is agreeing to service the University Campus throughout the Term, if, after the Closing Date, the University currently or thereafter leases, sub-leases, or otherwise provides a leasehold interest in real property served by the Utility System for less than or equal to the period of time remaining in the Term to a third party unaffiliated with the University, then, to the extent that it would not be prohibited by Law, the Concessionaire shall continue to provide Utilities to such real property in accordance with this Agreement, and the University shall remain obligated to pay the Utility Fee attributable to such real property. The Concessionaire is only entitled to the continued receipt of the Utility Fee attributable to such real property and shall have no interests or rights to charge or collect additional payments from the University, the lessees or sub-lessees for the provision of Utilities to such real property.
- (c) The University, at its discretion, may, pursuant to a University Directive, cause the Concessionaire to provide Utility Services to any portion of the University Campus not served by the Utility System at that time and may expand the definition of the University Campus.

ARTICLE 6 PERFORMANCE STANDARDS

Section 6.1. Compliance with Performance Standards. The Concessionaire shall, at all times during the Term, cause the Utility System Operations to comply with and implement the Performance Standards in all material respects (including any changes or modifications to the Performance Standards pursuant to the terms of this Agreement); provided that the Concessionaire shall have a reasonable period of time to comply with the introduction of changes or modifications to the Performance Standards that are made from time to time in accordance with the terms of this Agreement. From and after the date on which the Concessionaire is required to have an Operations Plan pursuant to the Performance Standards, the Concessionaire shall have in place at all times during the Term an Operations Plan. Except as specifically set forth herein, the Concessionaire shall perform all work required to comply

with and implement the Performance Standards (including the Capital Improvements described therein) as part of the Utility System Operations and at its sole cost and expense.

Section 6.2. Proposed Performance Standards. If the Concessionaire, at its cost and expense, wishes to implement and use performance standards for the operation of the Utility System other than the Performance Standards, the Concessionaire must provide notice of such proposed performance standards to the University for Approval. The Concessionaire's proposed performance standards must be accompanied by an explanation of the Concessionaire's rationale for making its proposal and all relevant supporting information, certificates, reports, studies, investigations and other materials as are necessary to demonstrate that the Concessionaire's proposed performance standards are reasonably designed to achieve or improve upon the intent of the applicable Performance Standards and are in compliance with Prudent Industry Practices and applicable Laws. The University may request any additional supporting information, certificates, reports, studies, investigations and other materials as are reasonably required by the University to determine if the Concessionaire's proposed performance standards are reasonably designed to achieve or improve upon the objectives of the applicable Performance Standards. Until the University provides its Approval for the implementation of the Concessionaire's proposed performance standards, the Concessionaire shall not implement the proposed performance standards and shall implement and comply with the Performance Standards. The Concessionaire's proposed performance standards shall be deemed incorporated into the Performance Standards upon Approval by the University in accordance with the terms hereof. It shall be unreasonable for the University to withhold its Approval if the proposed performance standards are reasonably designed to achieve or improve upon the intent of the applicable Performance Standards in a manner that does not unreasonably increase the cost to the University. If the University refuses to Approve any proposed performance standards and the Concessionaire disagrees with such refusal, the Concessionaire's sole remedy shall be to submit such dispute to the procedures set forth in Article 18.

Section 6.3. Modified Performance Standards.

- (a) The Parties acknowledge that the services provided hereunder by the Concessionaire to the University may impact the quality of life on the University Campus. Because of the importance to the University of maintaining high standards with respect to such campus life, the University shall have the right, at any time during the Term, to modify or change the Performance Standards upon notice to the Concessionaire to (i) comply with any new Law or change in Law applicable to the Utility System Operations or (ii) conform the Performance Standards to standards or practices generally adopted with respect to Comparable Utility Systems or Prudent Industry Practices; any such modification shall not constitute a Compensation Event. In the event the University modifies the Performance Standards in accordance with the immediately preceding sentence, the Concessionaire shall promptly perform all work required to implement and shall comply with all such modifications and changes and in no event shall the Concessionaire be excused from compliance with any such modification or change, except as otherwise expressly provided in this Agreement, the cost of which shall be included in Uncapped O&M Costs (but only to the extent of the costs incurred to cause the Utility System to

initially comply with such modification or change) or New Approved Capital Improvement Costs (if such modifications or changes are Capital Improvements); provided that the cost of ongoing compliance with any such modification or change may be included in Capped O&M Costs, if such costs would be included in the definition thereof. If (x) any such modification or change is a New Approved Capital Improvement, then the Concessionaire and the University shall determine in good faith the forecasted annual operations and maintenance costs for such New Approved Capital Improvement or (y) such modification or change is not a New Approved Capital Improvement but the Concessionaire and the University determine, in good faith, that it will require additional ongoing Capped O&M Costs after the completion of such modification or change, then, in each case, the Capped O&M Index shall increase by such amount. The Concessionaire shall have the right to challenge, pursuant to Article 18, any modified Performance Standard on the grounds that it does not meet the requirement of this Section 6.3(a). In connection with a change in the Performance Standard under this Section 6.3(a), the University and the Concessionaire shall cooperate in good faith to make any reasonably necessary adjustments to the Key Performance Indicators and any other Performance Standards as a result thereof.

- (b) If, during the Term, the University is of the opinion that a modification or change to the Performance Standards is necessary or desirable but such modification or change is not required by Section 6.3(a), the University may upon reasonable written notice to the Concessionaire modify or change the Performance Standards; provided, however, that any such change(s) or modification(s) in the aggregate in a Fiscal Year shall constitute a Compensation Event only if such change(s) or modification(s) (i) are not in response to any action or omission on the part of the Concessionaire or the Operator and (ii) result in an increase, during any Fiscal Year, in operating expenses attributable to compliance with such change(s) or modification(s) (taking into account all such previous changes or modifications applicable in such Fiscal Year or any previous Fiscal Year) in excess of \$75,000 (annually Adjusted for Inflation starting from the Year in which the Closing occurred) which cannot be charged through to the University as part of O&M Costs or recovered as a New Approved Capital Improvement Cost. At the University's request, the Concessionaire shall perform all work required to implement and shall comply with all such modifications and changes, and in no event shall the Concessionaire be excused from compliance with any such modification or change.
- (c) The University shall have the right to undertake the work necessary to ensure implementation of and compliance with any such modification or change to the Performance Standards if the Concessionaire fails to do so within a reasonable period of time; provided, however, that to the extent that such work is undertaken by the University, the Concessionaire shall pay to the University within 10 Business Days following demand therefor, or the University may offset from amounts owing to the Concessionaire in connection with such

modification or change, (i) with respect to changes pursuant to Section 6.3(a) all costs to comply with such Performance Standard and (ii) with respect to Section 6.3(b), the costs of the portion of the work performed in order to comply with the Performance Standards existing immediately prior to such modification or change, and the University shall be responsible only for the incremental costs of the additional work required in order to implement such proposed modification or change to the Performance Standards and, without duplication with the foregoing, the Concession Compensation with respect to such modification or change.

Section 6.4. Post-Closing Transition Period Assessment. During the Post-Closing Transition Period, the Concessionaire shall have the right to propose to the University modifications to the Performance Standards and Key Performance Indicators based on the Concessionaire's assessment of historic Utility System Operations, including reasonable evidence to support such modification. The University shall consider any such proposals in good faith but shall not be obligated to agree to any such modifications. If the Concessionaire and the University, each acting reasonably, agree to such modifications, they shall enter into an amendment to memorialize such changes. The Parties acknowledge no such modifications were made.

ARTICLE 7 UTILITY FEE, FIVE-YEAR PLAN, AND ENERGY SUPPLY

Section 7.1. Utility Fee.

- (a) As compensation for the services provided hereunder by the Concessionaire to the University in connection with the Utility System, the University shall pay to the Concessionaire the Utility Fee for each Fiscal Year or portion thereof during the Term as determined in accordance with the formula described in Schedule 5 and in the manner set forth in this Section 7.1. At least ~~180~~ten (10) Days and no more than thirty (30) Days prior to the commencement of any Fiscal Year during the Term (other than the first Fiscal Year), the Concessionaire shall provide a forecast of the Utility Fee excluding any Uncapped O&M Costs (as determined in accordance with Schedule 5, and subject to the limitations therein) to the University for the upcoming Fiscal Year (the "Forecast Utility Fee"), ~~provided that. Furthermore,~~ the Concessionaire shall, ~~by notice to the University (i) on or before 90 Days prior to the commencement of any Fiscal Year and (ii) again provide an adjusted Forecast Utility Fee~~ at least ten (10) Days and no more than thirty (30) Days prior to the commencement of such Fiscal Year, ~~adjust such Forecast Utility Fee as necessary, as determined by the Concessionaire in its good faith and reasonable discretion; provided, with respect to the Fiscal Year commencing on the first July 1 to occur after the Closing Date, the Concessionaire shall provide the Forecast Utility Fee to the University by the later of 180 Days) days~~ before the commencement of the ~~next~~ Fiscal Year ~~and 30 Days after the Closing Date~~Second Half (to reflect updates to the Variable Fee Component and Capital Recovery Amount), and upon commencement of such Fiscal Year Second Half, the Forecast Utility Fee (as well as the remaining

monthly installments for the remainder of that Fiscal Year) shall be updated to reflect such adjustment. The University shall pay the Forecast Utility Fee ~~in~~ 12 for the Fiscal Year First Half and for the Fiscal Year Second Half, respectively, in 6 equal monthly installments, payable on the first Day of every month during the applicable half of the Fiscal Year, provided that if the Term expires on a date that is not the last ~~day~~ Day of a Fiscal Year Half, the Forecast Utility Fee for that last partial Fiscal Year Half shall be prorated based on the number of Days in that last Fiscal Year Half. For the avoidance of doubt, the Fixed Fee and the Operating Fee shall not change between the Fiscal Year First Half and the Fiscal Year Second Half. The Forecast Utility Fee for the first Fiscal Year of the Term ~~shall be~~ was \$10,594,422.81 prorated based on the number of Days remaining in the first Fiscal Year after the Closing and ~~payable~~ paid in equal monthly installments over the number of months remaining in such Fiscal Year. For purposes of providing the Forecast Utility Fee for any Fiscal Year after the first Fiscal Year, the Parties shall meet in advance and, acting in good faith, shall agree on the methodology for determining the Forecast Utility Fee, including, but not limited to, estimations of the CPI Index and the Capped O&M Costs for the current Fiscal Year.

- (b) Within 60 Days after the end of each Fiscal Year, the Concessionaire shall deliver to the University a statement (the “Reconciliation Statement”) which states the actual Utility Fee (as determined in accordance with Schedule 5, and subject to the limitations therein) for such Fiscal Year and provides a detailed accounting of each component of the Utility Fee and of the Capped O&M Costs incurred in such Fiscal Year, in each case calculated in a form and with such detail as may be reasonably requested by the University for the determination of the Utility Fee set forth in the Reconciliation Statement, including the details described in Section 7.1(c) below. If the Reconciliation Statement reveals that the Utility Fee for a Fiscal Year (as determined in accordance with Schedule 5, and subject to the limitations therein) is more than the Forecast Utility Fee for that Fiscal Year that has been paid by the University, the University agrees to pay the Concessionaire the difference in a lump sum within 30 Days after receipt of the Reconciliation Statement. If the Reconciliation Statement reveals that the Utility Fee for such Fiscal Year is less than the Forecast Utility Fee for that Fiscal Year that has been paid by the University, the Concessionaire will pay the University the difference in a lump sum within 30 Days after receipt of the Reconciliation Statement. In addition to the foregoing, the Concessionaire shall deliver to the University the quarterly reporting described in Section 8.1(d).
- (c) In the Reconciliation Statement for each Fiscal Year, the Concessionaire shall set forth in reasonable detail (including any relevant backup documentation) the difference between the Baseline Capped O&M Costs and the actual Capped O&M Index for that Fiscal Year, which Capped O&M Index for that Fiscal Year shall be modified, solely for the purposes of this calculation, by making the following adjustments to the Capped O&M Costs used for each relevant prior Fiscal Year to calculate the Capped O&M Index for that Fiscal Year: (i) increase the applicable Fiscal Year’s Capped O&M Costs by the amount of Capped O&M

Costs that were avoided in that Fiscal Year as a direct result of the implementation of New Approved Capital Improvements; and (ii) excluding the Capped O&M Costs attributable to payroll and benefits due to employees that were engaged in the operations and maintenance of the Utility System (the “Annual Savings”). If the Annual Savings for a Fiscal Year is a positive amount, the Concessionaire shall be entitled to receive, as a component of the Utility Fee, an amount equal to 50% of the Annual Savings (the “Annual Savings Incentive”) for such Fiscal Year, provided that if some or all of such Annual Savings is due to a Non-Recurring Savings, the Concessionaire shall not be entitled to the Annual Savings Incentive associated therewith. The Annual Savings Incentive shall be calculated on a pro-rated basis in respect of any Fiscal Year which only partially falls within the Term.

- (d) The records that the Concessionaire maintains with respect to the calculation of the actual Utility Fee shall be retained by the Concessionaire for a period of 5 Fiscal Years following the Fiscal Year to which such Utility Fee applied. The University shall have the right, through its Representatives, to examine, copy and audit such records at reasonable times, upon not less than 5 Business Days’ prior notice, at such place within the City of Moscow, Idaho as the Concessionaire shall reasonably designate from time to time for the keeping of such records. All costs of any such audit shall be borne by the University; provided, however, that if such audit establishes that the Utility Fee for the applicable Fiscal Year was lower than the final determination thereof as set forth in the Reconciliation Statement, by at least 1.0%, then the Concessionaire shall pay the cost of such audit. If, as a result of such audit, it is determined that the University has overpaid the Concessionaire on account of the Utility Fee, then the Concessionaire shall reimburse the University for any (i) undisputed amounts within 30 Days after such determination and (ii) amounts which have been determined to be due pursuant to Article 18 within 30 Days after such determination. If the Concessionaire disputes the results of an audit conducted pursuant to this Section 7.1(d), the Concessionaire’s sole remedy shall be to submit such dispute to the procedures set forth in Article 18.
- (e) In addition, if an audit conducted pursuant to Section 7.1(d) establishes that the Utility Fee for the applicable Fiscal Year was lower than the final determination thereof, as set forth in the Reconciliation Statement, by at least 3.0%, then in addition to paying the cost of such audit and reimbursing the University for the payments in accordance with Section 7.1(d), the Concessionaire shall pay, as liquidated damages, 3 times the amount of the difference between the Utility Fee and the amount set forth in the Reconciliation Statement. The University and the Concessionaire agree that it would be impracticable and extremely difficult to fix the actual damage to the University if the actual Utility Fee was lower than the amount shown in the Reconciliation Statement by at least 3.0%. The University and the Concessionaire therefore agree that, in such instance, 3 times the amount of the difference between the Utility Fee and the amount set forth in the Reconciliation Statement is a reasonable estimate of the University’s damages and that the University shall be entitled to said sum as liquidated damages. If the

Concessionaire disputes the results of an audit conducted pursuant to Section 7.1(d), the Concessionaire's sole remedy shall be to submit such dispute to the procedures set forth in Article 18.

- (f) Within thirty (30) Days after the end of each Quarter, the Concessionaire shall provide to the University an invoice with the amount of Uncapped O&M Costs it incurred during such Quarter, including such reasonable evidence to support that they are Uncapped O&M Costs and the amount thereof. The University shall, within ten (10) Business Days of its receipt of such invoice, either (i) reimburse the Concessionaire for such amount of Uncapped O&M Costs or (ii) notify the Concessionaire that it disagrees with the determination of such amount of Uncapped O&M Costs (or any portion thereof) and the matter shall be submitted to the dispute resolution procedure in Article 18, provided that if the University only disputes a portion of such Uncapped O&M Costs, the University shall reimburse the Concessionaire the undisputed portion within ten (10) Business Days of receipt. Notwithstanding the foregoing, the University shall not be entitled to dispute any invoice, or portion thereof, submitted by the Concessionaire seeking payment for Uncapped O&M Costs to the extent that the Concessionaire notified the University by email or other writing of Concessionaire's intention to perform services associated with such Uncapped O&M Costs prior to performing such services and the University approved such request or the applicable portion thereof. For the avoidance of doubt, this shall be the sole method by which the Concessionaire is reimbursed for its Uncapped O&M Costs, and Uncapped O&M Costs shall not be included in the Utility Fee.

Section 7.2. Five-Year Plan.

- (a) The Concessionaire shall submit to the University a proposed Initial Five-Year Plan on or before 90 Days following the Closing Date and shall thereafter submit to the University a proposed Five-Year Plan at least 180 Days prior to the end of each Fiscal Year during the Term. Each proposed Five-Year Plan shall include the Capital Improvements and Material Changes (and shall identify whether an item requested for Approval is a Capital Improvement or Material Change or a combination thereof) that the Concessionaire proposes to make in each Fiscal Year in such proposed Five-Year Plan as well as anticipated O&M Costs, delineated between Capped O&M Costs and Uncapped O&M Costs, and the anticipated types of Supplies that will be used for each such Fiscal Year, including the estimated usage pattern over the course of the first Fiscal Year. The initial Five-Year Plan can include, and the University will consider in accordance with Section 4.3, proposed Capital Improvements and Material Changes to the Utility System to address any conditions of the Utility System existing prior to the Closing Date. Each proposed Five-Year Plan shall be submitted in a format reasonably acceptable to the University as of the date of submission.
- (b) The University shall review and provide comments to the Concessionaire on the proposed Five-Year Plan, provided that to the extent pertaining to proposed

Capital Improvements or Material Changes relating to the first full Fiscal Year in the proposed Five-Year Plan, such review and comments shall be conducted and provided in accordance with Section 4.3(c), and provided further that, subject to Section 7.2(c), if the University shall have previously Approved any such Capital Improvement or Material Change included in the proposed Five-Year Plan, the University shall not have the right to modify or rescind such prior Approval to the extent of such prior Approval. The Concessionaire shall promptly incorporate and use the University's comments on the proposed Five-Year Plan to prepare a revised version thereof and submit such revised version to the University. This process shall continue until the University Approves all components of the proposed Five-Year Plan, including the estimated usage of Supplies over the first Fiscal Year in such Five-Year Plan.

- (c) The proposed Five-Year Plan Approved by the University shall become the Approved Five-Year Plan as of the commencement of the first Fiscal Year in such proposed Five-Year Plan (or, in the case of the proposed Initial Five-Year Plan, as of the date of the University's Approval); provided, however, that no portion of an Approved Five-Year Plan related to the second through fifth full Fiscal Years therein shall be deemed Approved by the University, except to the extent that a Capital Improvement or Material Change is scheduled pursuant to such Approved Five-Year Plan to be started in the first full Fiscal Year and completed in the second through fifth full Fiscal Years therein. For the avoidance of doubt, the Approval of a Five-Year Plan that includes a Capital Improvement or Material Change that is not scheduled to be commenced until the second Fiscal Year therein at the earliest shall not be deemed an Approval of such Capital Improvement or Material Change for purposes of Article 4 or this Article 7.
- (d) If the Concessionaire does not accommodate or otherwise resolve any comment provided by the University pursuant to Section 7.2(b), the Concessionaire shall deliver to the University, within 10 Days after receipt of the University's comments, a written explanation as to why accommodation or other resolution of such comment would not allow the Concessionaire to meet the requirements of Section 3.2(a)(ii). The explanation shall include the facts, analyses and reasons that support the conclusion regarding such comment. Any dispute between the Concessionaire and the University over such comment shall be resolved pursuant to the procedures set forth in Article 18.
- (e) If a proposed Five-Year Plan or a portion thereof is not Approved by the commencement of the first Fiscal Year in such proposed Five-Year Plan, the Approved Five-Year Plan or relevant portion thereof shall continue in effect until a new proposed Five-Year Plan is Approved, provided that in the case of the proposed Initial Five-Year Plan, no Approved Five-Year Plan shall be in effect until the proposed Initial Five-Year Plan is Approved, and provided further that nothing in this Section 7.2 shall permit the Concessionaire to make a Capital Improvement or Material Change except if it is Approved in accordance with Section 4.3(c). Until the initial Five-Year Plan is Approved following the

Closing Date, the Concessionaire shall operate the Utility System in accordance with this Agreement and otherwise in substantially the same manner it had been operated immediately prior to Closing provided that nothing in this Section 7.2 shall permit the Concessionaire to make a Capital Improvement or Material Change except if it is Approved in accordance with Section 4.3(c).

- (f) For the avoidance of doubt, the Concessionaire's right to receive the Utility Fee, subject to the limitations contained herein and in Schedule 5, shall not be modified or superseded by the Approved Five-Year Plan.
- (g) Except as otherwise provided in Section 7.2(c), the contents of any Approved Five-Year Plan shall not be binding on any future Five-Year Plan.
- (h) Notwithstanding anything to the contrary in this Agreement, the Parties acknowledge and agree that all payments to the Operator pursuant to any agreement between the Concessionaire and the Operator to operate the Utility System that have been previously Approved by the University on or prior to the Closing Date, shall be deemed Approved and shall require no further Approval for any Five-Year Plan, provided that such payments do not materially differ from the payments or payment mechanics that were Approved by the University in its Approval of the Operator or otherwise.
- (i) In acknowledgement of the importance of the Utility System to the operation of the University Campus and the integrated delivery of services to students, employees, staff, faculty and visitors of the University Campus, the University Liaison and other University Representatives selected by the University will meet with a representative of the Concessionaire and the Operator on a quarterly basis in order to discuss and assess the implementation of the then-current Five-Year Plan, including any delays or failures to meet the then-current Five-Year Plan and discuss the development of the immediately subsequent Five-Year Plan.

Section 7.3. Energy and Water Supply.

- (a) The Concessionaire shall assist the University with the procurement of sufficient electricity, natural gas, biomass or other energy supply inputs and domestic water necessary to fully operate the Utility System as set forth in the Performance Standards (the "Supplies"). At the University's direction, assistance may include, but not be limited to, identification and development of Supply procurement opportunities, provision of market analysis and advice regarding the same, acting on behalf of the University to negotiate or assist in negotiating Supply purchases, acting on behalf of the University or assisting the University in the operation of bidding mechanisms to procure competitive retail Supplies. The University shall be responsible for paying all Supply Costs directly to the vendor of such Supplies. The University, in connection with its commitment to sustainability, minimization of environmental impact, responsible energy procurement, and its rights and responsibilities as the energy

Supply customer of record, shall enter into any contracts with a third party for providing Supplies to the Utility System (each, a “Supply Contract”); provided that the University shall have made a reasonable determination that each such Supply Contract is consistent with the then-current Approved Five-Year Plan or has issued a University Directive with respect to such Supply Contract. The University shall, in its sole discretion, determine the types and sources of the Supplies and the appropriate entity (among the Concessionaire, the Operator and the University) to execute each Supply Contract and, if applicable, any Authorization related to Supplies, described in Section 7.3(d), with the Concessionaire or Operator executing pursuant to a power of attorney, and the Concessionaire shall operate the Utility System consistent with the types and sources of Supplies determined by the University. In any case, regardless of which entity executes a Supply Contract, the University will be considered as the exclusive customer of the Supplies procured pursuant to this Section 7.3(a) or used for the operation of the Utility System. Notwithstanding the foregoing, the Parties acknowledge that as of the Time of Closing, there shall be in place certain Supply Contracts to provide Supplies as described in Schedule 6, and the Concessionaire’s obligations under this Section 7.3(a) with respect to the Supplies which are the subject of such Supply Contract shall be met by managing those Supply Contracts until their expiration or termination, at which time the Concessionaire shall be responsible for assisting the University with the procurement of those Supplies for the University Campus as provided herein immediately following the expiration or termination of those Supply Contracts. For the avoidance of doubt, if the third-party supplier of the Supplies fails to deliver such Supplies pursuant to the applicable Supply Contract, (i) such failure shall be a Delay Event (except with respect to any failure to deliver Supplies on University locations outside of the University Campus)—~~and~~, (ii) the Concessionaire, acting on behalf of the University, shall use commercially reasonable efforts to cause such third-party supplier to deliver such Supplies as soon as reasonably practicable, and (iii) as necessary, the Concessionaire shall assist the University with the prompt replacement of such third-party supplier.

- (b) The Concessionaire shall, upon written notice from the University, be responsible for assisting the University with the procurement, billing and/or management of Supplies to the University or its Affiliates on University locations outside of the University Campus, and such assistance with the procurement, billing and/or management of Supplies shall be deemed part of the Utility System Operations. For clarification purposes, the Concessionaire shall be responsible for assisting the University with the management of Supplies under any existing Supply Contract described in Schedule 6 as provided in Section 7.3(a).
- (c) The Concessionaire shall ensure that any Supply Contracts negotiated by the Concessionaire provide that invoices are remitted to the Concessionaire, if so requested by the University in writing, or to such other entity as identified by the University. Promptly after receipt of such an invoice for Supply Costs from a third party but in no event more than 5 Business Days after receipt thereof, the

Concessionaire shall forward the supplier's invoice to the University, and the Concessionaire shall have no obligation to pay such Supply Costs.

- (d) The Concessionaire shall be responsible for extracting the domestic water used for the Utility System from the aquifers appurtenant to the University Campus in accordance with, and as a licensee of the University with respect to, the applicable Authorizations therefor or such other source as Approved by the University, provided that, for the avoidance of doubt, the University shall not be required to convey, nor deemed or considered, to have conveyed any of its water rights to the Concessionaire.
- (e) The Concessionaire shall cause the Utility System to be operated using a mix of Supplies supported by the then-current Supply Contracts and the Approved Five-Year Plan. The Concessionaire shall consult the University with respect to any adjustments to the mix of Supplies required to operate the Utility System in accordance with this Agreement and any such adjustments shall only be made upon Approval from the University, which may be withheld in its sole discretion.

Section 7.4. Energy Use Intensity Reduction and Energy Conservation Measures.

In furtherance of the objectives set forth in Section 3.29, within 2 Years after the Closing Date, the University shall have the right to request in writing that the Concessionaire diligently prepare and provide to the University a detailed study with recommendations and proposals for opportunities to reduce the energy use intensity on the University Campus, and the Concessionaire shall in good faith discuss with the University the Concessionaire implementing such recommendations and proposals. In addition, in connection with each Five-Year Plan, the Concessionaire may propose certain measures or improvements on the University Campus, including energy conservation measures, buying strategies in connection with Supplies, or such other improvements anticipated to achieve an energy use intensity reduction. The University may consider such proposals in its discretion in connection with reviewing such Five-Year Plan and any Approval of the same may include a shared savings of costs with respect thereto.

ARTICLE 8 REPORTING; AUDITS; INSPECTIONS

Section 8.1. Reports; Environmental Incident Management.

- (a) *Incident Management and Notifications.* The Concessionaire shall (i) provide notice to the University of all Emergencies as promptly as possible, and, in any event, not later than 6 hours after the Concessionaire or the Operator becomes aware of the Emergency, and (ii) promptly provide notice to the University of all material accidents and incidents occurring with respect to the Utility System and of all claims in excess of \$25,000 annually made by or against the Concessionaire or potential claims in excess of \$25,000 annually that the Concessionaire reasonably expects to make against, or to be made against it by, third parties.

- (b) *Environmental Incident Management and Notifications.* The Concessionaire shall provide notice to the University as promptly as possible, and, in any event, not later than 6 hours after the Concessionaire becomes aware of the Release (accidental or otherwise) of any reportable quantity, as defined under applicable Environmental Law, of Hazardous Substances occurring with respect to the Utility System or otherwise on the University Campus or any part thereof, which notice shall include the time of such Release, the agencies involved, the damage that has occurred and the remedial action taken. The Concessionaire shall be financially responsible and shall pay the costs and expenses of any remediation required as a result of any such Release of Hazardous Substances caused by the willful misconduct or negligent action of, or permitted by the negligent inaction of, the Concessionaire or any of its Representatives, which costs shall not be recoverable by the Concessionaire as part of the Utility Fee or otherwise pursuant to this Agreement, and the Concessionaire shall not be financially responsible for other Releases of Hazardous Substances from the Utility System. Regardless of the foregoing, unless such Release is an Excluded Liability, the Concessionaire shall be responsible for the remediation of any Releases of Hazardous Substances from the Utility System. The Concessionaire shall not be financially responsible for the actions or inactions of third parties except for (i) those actions or inactions with respect to which the Concessionaire or any of its Representatives shall have had prior knowledge of and could have used commercially reasonable efforts to prevent or mitigate and (ii) those actions or inactions consented in writing to or directed in writing by the Concessionaire or any of its Representatives. As between the University and the Concessionaire, the University shall be designated the generator for the disposal of all Hazardous Substances or other contamination, except for any Hazardous Substances that were Released by the willful misconduct or negligent action of, or permitted by the negligent inactions of, the Concessionaire, the Operator or any of their respective Representatives.
- (c) *Financial Reports.* The Concessionaire shall deliver to the University within 120 Days after the end of each Fiscal Year a copy of the audited balance sheets of the Concessionaire at the end of each such Fiscal Year and the related audited statements of income, changes in equity and cash flows for such Fiscal Year, including, in each case, the notes thereto, together with the report thereon of the independent certified public accountants of the Concessionaire, in each case in a manner and containing information consistent with the Concessionaire's current practices and certified by the Concessionaire's chief financial officer that such financial statements fairly present the financial condition and the results of operations, changes in equity and cash flows of the Concessionaire as of the respective dates of and for the periods referred to in such financial statements, all in accordance with GAAP or IFRS, provided that if such financial statements are prepared in accordance with IFRS, such financial statements shall include a reconciliation statement setting forth any material discrepancies between IFRS and GAAP reporting with respect to the subject matter thereof. The Concessionaire's independent certified public accountants shall be subject to the University's Approval. The annual reasonable, actual out-of-pocket cost of

preparing these audited financial statements shall, for the first three Fiscal Years (and any partial Fiscal Year) after the Closing be treated as Uncapped O&M Costs, and shall not be included in the calculation of the Capped O&M Index, and, after such period has elapsed, those reasonable, actual out-of-pocket costs shall be considered Capped O&M Costs and included in the Capped O&M Index by taking them into account in the calculation of historical Capped O&M Costs for the prior 3 Fiscal Years in the manner specified in the definition of “Capped O&M Index” in Schedule 5).

- (d) *Utility Fee Reports.* The Concessionaire shall deliver to the University within 30 Days after the end of each Quarter during a Fiscal Year a report showing (i) the calculation of the Variable Fee Component for that Quarter, (ii) the amount of O&M Costs incurred to date for such Fiscal Year, delineated between Capped O&M Costs and Uncapped O&M Costs, and (iii) the anticipated expenditures on Capital Improvements and Material Changes for the remainder of such Fiscal Year.
- (e) *Regular Reports.* The Concessionaire shall deliver to the University all reports and information as set forth in the Performance Standards in the time and format described in the Performance Standards.

Section 8.2. Information.

- (a) *Furnish Information.* At the request of the University, the Concessionaire shall, at the Concessionaire’s cost and expense and at any and all reasonable times during the Term: (i) make available or cause to be made available (and, if requested by the University, furnish or cause to be furnished) to the University all information relating to the Utility System Operations, this Agreement or the Utility System as may be specified in such request and as shall be in the possession or control of the Concessionaire or its Representatives, and (ii) permit the University, after giving 10 Business Days’ prior notice to the Concessionaire (which notice shall identify the Persons the University requests to be present for an interview and describe with reasonable specificity the subject matter to be raised in the interview) to request the Concessionaire’s approval, which approval shall not be unreasonably withheld, conditioned, or delayed, to discuss the obligations of the Concessionaire under this Agreement with any of the directors, officers, employees or managers of the Concessionaire, the Operator or their respective Representatives at times and places on the University Campus acceptable to all attendees (it being agreed that the Concessionaire shall have the right to be present during any such discussions with the Operator or Representatives of the Concessionaire or the Operator), for the purpose of enabling the University to determine whether the Concessionaire is in compliance with this Agreement. For the avoidance of doubt, this Section 8.2(a) does not impose a requirement to retain information not otherwise retained in the normal course of business or required to be retained by applicable Law.

- (b) *Confidentiality.* Unless disclosure is required by applicable Law, the University shall keep confidential any information obtained from the Concessionaire or its Representatives that constitutes a “trade secret” as defined by applicable Idaho Law, including Idaho Code § 48-801, as determined by the University in its reasonable discretion. In the event that the Concessionaire seeks to defend an action seeking the disclosure of information that the Concessionaire determines to be confidential pursuant to this Section 8.2(b), the University shall use commercially reasonable efforts to cooperate in such action at no out-of-pocket cost to the University, provided that the University shall not be required to institute any legal action against the requesting party. Notwithstanding anything to the contrary herein, the University and the Concessionaire may disclose the United States federal tax treatment and tax structure of the Transaction.

Section 8.3. Inspection, Audit and Review Rights of the University.

- (a) *Audit Right.* In addition to the rights set out in Section 7.1(d) and Section 8.2, the University may, at all reasonable times, upon 10 Business Days’ prior notice, cause a Representative designated by it to carry out an Audit and Review of the information required to be maintained or delivered by the Concessionaire under this Agreement in connection with the performance of the Utility System Operations for the purpose of verifying the information contained therein verifying Utility System Operations and to otherwise track utility usage patterns and shall be entitled to make copies thereof and to take extracts therefrom, at the University’s expense but, in any event, subject to Section 8.2(b). The Concessionaire shall, at reasonable times, make available or cause to be made available to the University or its designated Representative such information and material as may reasonably be required by the University or its designated Representative for its purposes and otherwise provide such cooperation as may be reasonably required by the University in connection with the same; provided, however, that such Audit and Review rights are limited to one Audit and Review per Fiscal Year.
- (b) *Inspection Right.* The University and its Representatives shall, at all reasonable times and upon reasonable prior notice and subject to the Concessionaire’s reasonable safety requirements and protocols, have access to the Utility System and every part thereof, and the Concessionaire, at the reasonable cost and expense of the Concessionaire, shall and shall cause its Representatives to furnish the University with every reasonable assistance for inspecting the Utility System and the Utility System Operations for the purpose of Auditing and Reviewing the information relating to the Utility System Operations or ascertaining compliance with this Agreement and applicable Law subject to reasonable restrictions on access to confidential and proprietary information as determined by the Concessionaire.
- (c) *Tests.* The University and its Representatives shall, with the prior consent of the Concessionaire, which consent shall not be unreasonably withheld, conditioned or delayed, be entitled, at the sole cost and expense of the University and at any

time and from time to time, to perform or cause to be performed, in accordance with Prudent Industry Practices, any test, study or investigation in connection with the Utility System or the Utility System Operations as the University may reasonably determine to be necessary in the circumstances, and the Concessionaire, at the cost and expense of the Concessionaire, shall, and shall cause its Representatives to, furnish the University or its Representatives with reasonable assistance in connection with the carrying out of such tests, procedures, studies and investigations.

- (d) *No Waiver.* Failure by the University or its Representatives to inspect, review, test or Audit and Review the Concessionaire's responsibilities under this Agreement or any part thereof, or the performance by the Concessionaire of the Utility Services, or the information relating to the Utility System Operations, shall not constitute a waiver of any of the rights of the University hereunder or any of the obligations or liabilities of the Concessionaire hereunder. Inspection, review, testing or Audit and Review not followed by a notice of Concessionaire Default shall not constitute a waiver of any Concessionaire Default or constitute an acknowledgement that there has been or will be compliance with this Agreement and applicable Law.
- (e) *No Undue Interference.* In the course of performing its inspections, reviews, tests and Audits and Reviews hereunder, the University shall minimize the effect and duration of any disruption to or impairment of the Utility System Operations or the Concessionaire's rights or responsibilities under this Agreement, having regard to the nature of the inspections, reviews, tests and Audits and Reviews being performed, except as necessary in the case of investigations of possible criminal conduct or University ordinance violations.

Section 8.4. Audits, Assistance, Inspections and Approvals. Wherever in this Agreement reference is made to the University or its Representatives providing assistance, services, Approvals or consents to or on behalf of the Concessionaire or its Representatives or to the University or its Representatives performing an Audit and Review or inspecting, testing, reviewing or examining the Utility System, the Utility System Operations or any part thereof or the books, records, Documents, budgets, proposals, requests, procedures, certificates, plans, drawings, specifications, contracts, agreements, schedules, reports, lists or other instruments of the Concessionaire or its Representatives, such undertaking by the University or its Representatives shall not relieve or exempt the Concessionaire from, or represent a waiver of, any requirement, liability, Concessionaire Default, covenant, agreement or obligation under this Agreement or at law or in equity and shall not create or impose any requirement, liability, covenant, agreement or obligation (including an obligation to provide other assistance, services or Approvals) on the University or its Representatives not otherwise created or imposed pursuant to the express provisions of this Agreement.

ARTICLE 9 REPRESENTATIONS AND WARRANTIES

Section 9.1. Representations and Warranties of the University. The University ~~makes~~made the following representations and warranties to the Concessionaire as of the Signing Date and acknowledges that the Concessionaire and its Representatives ~~are relying~~relied upon such representations and warranties in entering into ~~this~~the Original Agreement:¹⁶

- (a) *Organization.* The University is a state institution of higher education and body politic and corporate organized and existing under and pursuant to the Constitution and laws of the State of Idaho.
- (b) *Power and Authority.* The University has (i) duly authorized and approved the execution and delivery of ~~this~~the Original Agreement and (ii) duly authorized and approved the performance by the University of its obligations contained in ~~this~~the Original Agreement. The University has the power and authority to enter into ~~this~~the Original Agreement and to do all acts and things and execute and deliver all other documents as are required ~~hereunder~~thereunder to be done, observed or performed by it in accordance with the terms ~~hereof~~thereof.
- (c) *Enforceability.* ~~This~~The Original Agreement has been duly authorized, executed and delivered by the University and constitutes a valid and legally binding obligation of the University, enforceable against the University in accordance with the terms ~~hereof~~thereof, subject only to applicable bankruptcy, insolvency and similar laws affecting the enforceability of the rights of creditors generally and to general principles of equity.
- (d) *Title.* At the Time of Closing, the University will have good and sufficient title to the Utility Facilities, the Utility System Land, the Utility System Assets and the Tunnels necessary for the Utility System Operations pursuant to ~~this~~the Original Agreement, subject only to Permitted University Encumbrances, and will be able to transfer or grant such interest to the Concessionaire as provided in ~~this~~the Original Agreement. Subject to any and all Permitted University Encumbrances existing at the Time of Closing and to the Actual Knowledge of the University, there is no recorded or unrecorded agreement, contract, option, commitment, right, privilege or other right of another binding upon, or which at any time in the future may become binding upon, the University to sell, transfer, convey, subject to lien, charge, grant a security interest in or in any other way dispose of or materially encumber the Utility System. Subject to any and all Permitted University Encumbrances and to the Actual Knowledge of the University, the recorded or unrecorded restrictions, exceptions, easements, rights of way, reservations, limitations, interests and other matters that affect title to the Utility System (or any portion thereof) do not materially adversely affect the Concessionaire's ability to operate the Utility System in accordance with the terms ~~hereof~~thereof. No indebtedness for borrowed money of the University is or will be secured by any right or interest in the Utility System or the revenues or income therefrom, and no Person will have any claim or right to, or interest in, any income, profits, rents or revenue derived by the Concessionaire from or

¹⁶ NTD: These changes are necessary so as to not bring down all representations and warranties.

generated with respect to the Utility System (other than the Concessionaire and any claims, rights or interests granted by or otherwise relating to the Concessionaire); provided, however, the foregoing shall not apply to (i) revenues to which the University is or may be entitled to under ~~this~~the Original Agreement, (ii) revenues or income derived after the End Date, (iii) revenues or income received by the University from students or (iv) revenues or income received by the University from third parties as reimbursement for Utilities received by such parties.

- (e) *No Conflicts.* The execution and delivery of ~~this~~the Original Agreement by the University, the consummation of the Transaction (including the operation of the Utility System in accordance with the terms of ~~this~~the Original Agreement) and the performance by the University of the terms, conditions and provisions ~~hereof~~thereof have not and will not contravene or violate or result in a breach of (with or without the giving of notice or lapse of time, or both) or acceleration of any material obligations of the University under (i) any applicable Law, (ii) any agreement, instrument or document to which the University is a party or by which it is bound or (iii) the University's governing documents.
- (f) *Consents.* No Consent that has not already been obtained is required to be obtained by the University from, and no notice or filing that has not already been given is required to be given by the University to or made by the University with, any Person (including any Governmental Authority) in connection with the execution, delivery and performance by the University of ~~this~~the Original Agreement or the consummation of the Transaction.
- (g) *Compliance with Law; Litigation; Environmental Matters.*
- (i) The University has operated and ~~is~~was operating the Utility System as of the Signing Date in compliance, in all material respects, with all applicable Laws, and the University is not in breach of any applicable Law, in either case, that would reasonably be expected to have a Material Adverse Effect or a material adverse effect on the Concessionaire. To the Actual Knowledge of the University, (A) the University is in compliance, in all material respects, with the terms and conditions of all Authorizations from Governmental Authorities, (B) no claim has been made by any Governmental Authority to the effect that an Authorization that the University has not obtained is necessary in respect of the operation of the Utility System, and (C) no additional Authorizations from any Governmental Authority are necessary for the operation of the Utility System as currently being operated.
- (ii) The University has not been served with notice of any action, suit or proceeding, at law or in equity, or before or by any Governmental Authority, and to the Actual Knowledge of the University, there is no such action, suit or proceeding pending or threatened against the University prior to or at the Time of Closing, which would reasonably be expected to

have a Material Adverse Effect or a material adverse effect on the Concessionaire. As of the ~~date hereof~~ [Signing Date](#), there ~~is~~ [was](#) no action, suit or proceeding, at Law or in equity, or before or by any Governmental Authority, pending nor, to the Actual Knowledge of the University, threatened against the University which could materially affect the validity or enforceability of ~~this~~ [the Original](#) Agreement.

- (iii) There has been no Release of Hazardous Substances at, on or under the Utility Facilities that would reasonably be expected to have a Material Adverse Effect or a material adverse effect on the Concessionaire, except as cured to the satisfaction of the applicable Governmental Authority. To the Actual Knowledge of the University, (a) there is no pending investigation by a Governmental Authority concerning any Release of Hazardous Substances in connection with the Utility System or the Utility Facilities and (b) there has been no Release of Hazardous Substances in connection with the Utility System or the Utility Facilities that could reasonably result in liability to the Concessionaire.
- (h) *Financial Information.* The financial information of the University relating to the Utility System attached hereto as [Schedule 9](#), which identifies operational costs for the periods that ended June 30, 2018 through June 30, 2020, and, fairly presents the financial information disclosed thereon in accordance with standard accounting procedures of the University with respect to the Utility System, and is adjusted for anticipated expenditures the Concessionaire will incur to operate the Utility System as it is currently operated.
- (i) *Absence of Changes.* Since June 30, 2020 [through the Signing Date](#), there has not been any transaction or occurrence that has resulted or is reasonably likely to result in a Material Adverse Effect or a material adverse effect on the University. Since June 30, 2020 through the Closing, the University and the University's Contractors have operated the Utility System in a manner consistent with past practice and have not, for example, intentionally increased or decreased efforts and resources related to operations, maintenance or enforcement so as to reduce the value of the Concessionaire Interest.
- (j) *Brokers.* Except for Wells Fargo Securities, LLC ("[Wells Fargo](#)") and Rieth Jones Advisors ("[RJA](#)"), whose fees will be paid by the University, there is no investment banker, broker, finder or other intermediary which has been retained by or is authorized to act on behalf of the University who might be entitled to any fee or commission from the University in connection with the Transaction. There is also no investment banker, broker, finder or other intermediary which has been retained by or is authorized to act on behalf of the University who might be entitled to any fee or commission from the Concessionaire in connection with the Transaction.
- (k) *Accuracy of Information.* To the Actual Knowledge of the University, the factual and past historical information regarding the Utility System that the

University provided to the Concessionaire in the virtual data room labeled “Project Vikings” hosted by Datasite was accurate in all material respects at the time such information was prepared, except to the extent the University removed, revised or replaced such information prior to the Setting Date.

- (l) *Undisclosed Defects.* To the Actual Knowledge of the University, there are no material defects of the Utility System that could reasonably be expected to prevent the Utility System from being operated in accordance with the Performance Standards and Prudent Industry Practices.

By executing this Agreement, the University is not deemed to have re-made or affirmed any of the foregoing representations and warranties.

Section 9.2. Representations and Warranties of the Concessionaire. The Concessionaire ~~makes~~made the following representations and warranties to the University ~~(as of the Signing Date~~ and acknowledges that the University ~~is—relying~~relied upon such representations and warranties in entering into ~~this~~the Original Agreement):¹⁷

- (a) *Organization.* The Concessionaire is duly organized, validly existing and in good standing under the laws of the state of its organization. The capital stock, units, partnership or membership interests and other equity interests or securities of the Concessionaire (including options, warrants and other rights to acquire any such equity interests) are owned by the Persons set forth in the written certification that the Concessionaire delivered to the University prior to the ~~date~~hereofSigning Date.
- (b) *Power and Authority.* The Concessionaire has the power and authority to enter into ~~this~~the Original Agreement and to do all acts and things and execute and deliver all other documents as are required ~~hereunder~~thereunder to be done, observed or performed by it in accordance with the terms ~~hereof~~thereof.
- (c) *Enforceability.* ~~This~~The Original Agreement has been duly authorized, executed and delivered by the Concessionaire and constitutes a valid and legally binding obligation of the Concessionaire, enforceable against it in accordance with the terms ~~hereof~~thereof, subject only to applicable bankruptcy, insolvency and similar laws affecting the enforceability of the rights of creditors generally and to general principles of equity.
- (d) *No Conflicts.* The execution and delivery of ~~this~~the Original Agreement by the Concessionaire, the consummation of the Transaction and the performance by the Concessionaire of the terms, conditions and provisions ~~hereof~~thereof have not and will not contravene or violate or result in a material breach of (with or without the giving of notice or lapse of time, or both) or acceleration of any material obligations of the Concessionaire under (i) any applicable Law, (ii) any material agreement, instrument or document to which the Concessionaire is a

¹⁷ NTD: These changes are necessary so as to not bring down all representations and warranties.

party or by which it is bound or (iii) the articles, bylaws or governing documents of the Concessionaire.

- (e) *Consents.* No Consent that has not already been obtained is required to be obtained by the Concessionaire from, and no notice or filing that has not already been given is required to be given by the Concessionaire to, or made by the Concessionaire with, any Person (including any Governmental Authority) in connection with the execution, delivery and performance by the Concessionaire of ~~this~~[the Original](#) Agreement or the consummation of the Transaction, except for such consents which have been or will be obtained and notices which have been or will be given as of the Closing Date.
- (f) *Compliance with Law; Litigation.* The Concessionaire is not in breach of any applicable Law that could have a Material Adverse Effect. Neither the Concessionaire nor any Affiliate of the Concessionaire is (a) listed on any of the following lists maintained by the Office of Foreign Assets Control of the U.S. Department of the Treasury, the Bureau of Industry and Security of the U.S. Department of Commerce, the Department of State, or their successors or on any other list of Persons with which the University is prohibited from engaging in business under applicable Law: the Specially Designated Nationals and Blocked Persons List, the Sectoral Sanctions Identifications List, the Denied Persons List, the Unverified List, the Entity List, and solely with respect to the Concessionaire and its parent, the Debarred List; or (b) controlled or 50% or more owned, directly or indirectly, individually or in the aggregate, by one or more Persons on a list identified in [clause \(a\) above](#). The Concessionaire has not been served with notice of any suit or proceeding, at law or in equity, or before or by any Governmental Authority and to the best of the Concessionaire's knowledge, there is no such action, suit or proceeding threatened against the Concessionaire prior to or at the Time of Closing, which will have a material adverse effect on (i) the Transaction or (ii) the validity or enforceability of ~~this~~[the Original](#) Agreement.
- (g) *Prohibited Tax Shelter Transaction.* The Concessionaire has not entered into, and will not enter into, any lease, sublease, concession, management agreement, operating agreement or other similar arrangement or other transaction that would cause the University to become a party to a "prohibited tax shelter transaction" within the meaning of Section 4965 of the Code, including by virtue of the execution of ~~this~~[the Original](#) Agreement or any lease, sublease, concession, management agreement, operating agreement or other similar arrangement or other transaction to which the University has consented to pursuant to the arrangements contemplated by ~~this~~[the Original](#) Agreement.
- (h) *Accuracy of Information.* To the actual knowledge of the Concessionaire, all information regarding the Concessionaire or the Operator provided to the University by or on behalf of the Concessionaire or the Operator was accurate in all material respects at the time such information was provided.

- (i) *Operator.* To the extent the Operator is not the Concessionaire, the Concessionaire represents and warrants as follows: (i) the Operator is duly organized, validly existing and in good standing under the laws of the state of its organization; (ii) the capital stock or other equity interests of the Operator (including options, warrants and other rights to acquire capital stock) is owned by the Persons set forth in the written certification that the Concessionaire delivered to the University prior to the ~~date hereof~~Signing Date; (iii) the Operator has the power and authority to do all acts and things and execute and deliver all other documents as are required ~~hereunder~~under the Original Agreement to be done, observed or performed by it in connection with its engagement by the Concessionaire; (iv) the Operator has all necessary expertise, qualifications, experience, competence, skills and know-how to perform the Utility System Operations in accordance with ~~this~~the Original Agreement; (v) the Operator is not in breach of any applicable Law that would have a Material Adverse Effect; and (vi) is authorized to do business in the State of Idaho, and, except the extent such licenses and permits are set forth on Schedule 18, has all licenses and permits required to perform its obligations hereunder, which representations shall be only to the best knowledge of the Concessionaire in the event that the Operator is not an Affiliate of the Concessionaire.
- (j) *Brokers.* Except for Plenary Americas USA Ltd., whose fees will be paid by the Concessionaire or its Affiliates, there is no investment banker, broker, finder or other intermediary which has been retained by or is authorized to act on behalf of the Concessionaire or any of its Affiliates who might be entitled to any fee or commission in connection with the Transaction which could become a claim on, a liability of, or an Encumbrance on, the Utility System.

By executing this Agreement, the Concessionaire is not deemed to have re-made or affirmed any of the foregoing representations and warranties.

Section 9.3. Non-Waiver. No investigations made by or on behalf of any Party at any time shall have the effect of waiving, diminishing the scope of or otherwise affecting any representation or warranty made by the other Party in this Agreement or pursuant to this Agreement. No waiver by a Party of any condition, in whole or in part, shall operate as a waiver of any other condition.

Section 9.4. Survival.

- (a) *University's Representations and Warranties.* The representations and warranties of the University contained in Section 9.1 shall survive and continue in full force and effect for the benefit of the Concessionaire as follows: (i) as to the representations and warranties contained in Sections 9.1(a) through 9.1(g), inclusive, without time limit; and (ii) as to all other matters, for a period of 24 months following the Closing Date unless a bona fide notice of a Claim shall have been given, in writing, in accordance with Section 20.1, prior to the expiry of that period, in which case the representation and warranty to which such notice applies shall survive in respect of that Claim until the final determination

or settlement of that Claim, provided such determination or settlement is being pursued diligently and in good faith by the applicable Party.

- (b) *Concessionaire's Representations and Warranties.* The representations and warranties of the Concessionaire contained in Section 9.2 shall survive and continue in full force and effect for the benefit of the University as follows: (i) as to the representations and warranties contained in Sections 9.2(a) through 9.2(i), inclusive, without time limit; and (ii) as to all other matters, for a period of 24 months following the Closing Date unless a bona fide notice of a Claim shall have been given, in writing, in accordance with Section 20.1, before the expiry of that period, in which case the representation and warranty to which such notice applies shall survive in respect of that Claim until the final determination or settlement of that Claim, provided such determination or settlement is being pursued diligently and in good faith by the applicable party.
- (c) *Modification of Statutes of Limitations.* The survival periods set forth in this Section 9.4 shall apply with respect to all Claims notwithstanding any statute of limitations that would be applicable to such Claims under applicable Law. The Parties acknowledge and agree that they intend to modify the statutes of limitations with respect to all Claims to the extent such statutes of limitations would conflict with the provisions set forth in this Section 9.4.

ARTICLE 10 FINANCE OBLIGATIONS

Section 10.1. Concessionaire's Obligations. The Concessionaire shall be responsible for obtaining any financing for the performance of its obligations under this Agreement, which financing shall comply with all requirements of this Agreement. The Concessionaire shall be permitted to issue additional Leasehold Mortgage Debt or refinance existing Leasehold Mortgage Debt at any time during the Term provided that, as a condition thereof, the Concessionaire must comply with Section 3.6 in connection therewith.

Section 10.2. University's Obligations. The University shall, to the extent consistent with applicable Law and at the sole cost and expense of the Concessionaire, cooperate with the Concessionaire with respect to documentation reasonably necessary to obtain, maintain and replace financing for the performance of the obligations of the Concessionaire hereunder. The University's cooperation may include reviewing, Approving and executing documents which substantiate the terms of this Agreement (including any consents or agreements necessary to confirm that the debt evidenced by the relevant financing constitutes a Leasehold Mortgage Debt) and making information and material relating to the Utility System Operations available to any of the Concessionaire's lenders or proposed lenders to facilitate financing to the extent permitted by applicable Law and contractual obligations with third parties and to the extent reasonable in the circumstances, provided that such lenders and potential lenders shall hold such information in confidence (provided that such lenders and potential lenders may disclose such information to Affiliates and their respective officers, employees, agents, advisors, stockholders, partners, members, accountants and attorneys to the extent the foregoing agree to maintain such information as confidential in accordance with this Section 10.2 or as may be compelled in a

judicial, regulatory (including any self-regulatory organization) or administrative proceeding or as otherwise required by applicable Law or required by any Governmental Authority having jurisdiction over the lender) and the Concessionaire shall be liable for any disclosure by such lenders or potential lenders in breach thereof. If requested in writing to do so by the Concessionaire, the University shall, at the sole cost and expense of the Concessionaire, use its commercially reasonable efforts to cause the University's independent public accountants to reasonably cooperate in connection with the Concessionaire's public or private offering of securities, as the case may be. In addition, the University shall, promptly upon the request of the Concessionaire or any Leasehold Mortgagee, execute, acknowledge and deliver to the Concessionaire, or any of the parties specified by the Concessionaire, standard consents and estoppel certificates with respect to this Agreement which may be qualified, after reasonable diligence, to the best of the knowledge and belief of a designated Representative of the University. Nothing herein shall require the University to incur any additional obligations or liabilities (unless the University shall have received indemnification, as determined in the University's discretion, with respect thereto), to take any action or give any consent or enter into any document inconsistent with the provisions of this Agreement.

Section 10.3. Concessionaire's Obligation for Estoppel Certificates. The Concessionaire shall, promptly upon the request of the University, execute and deliver to the University, or any of the parties specified by the University, standard consents and estoppel certificates with respect to this Agreement which may be qualified to the best of the knowledge and belief of a designated Representative of the Concessionaire. Nothing herein shall require the Concessionaire to incur any additional obligations or liabilities or to take any action, give any consent or enter into any document inconsistent with the provisions of this Agreement or applicable Law.

Section 10.4. Prohibited Tax Shelter Transactions. Consistent with Section 9.2(g), the Concessionaire covenants and agrees that it shall not enter into any lease, sublease, concession, management agreement, operating agreement or other similar arrangement or other transaction that would cause the University to become a party to a "prohibited tax shelter transaction" within the meaning of Section 4965 of the Code. A violation of this Section 10.4 or a breach of the representation set forth in Section 9.2(g) by the Concessionaire shall entitle the University to (a) recover from the Concessionaire the amount of any Tax liability, penalty or loss to which the University or any University official is subject and (b) require the Concessionaire, at the Concessionaire's expense, to prepare timely all statements and returns, and to maintain all lists and similar information that the University becomes obligated to disclose, file or maintain with any taxing authority or participant or otherwise as a result of such transaction.

ARTICLE 11 COMPLIANCE

Section 11.1. Compliance with Laws. The Concessionaire must at all times at its own cost and expense (but subject to the Concessionaire's express rights hereunder with respect to such costs and expenses, including its right to include the reasonable cost of compliance with any Law enacted after the Setting Date in the Uncapped O&M Costs in accordance with the definition thereof) observe and comply, in all material respects, and cause the Utility System Operations to observe and comply, in all material respects, with all applicable Laws now

existing or later in effect, including those Laws expressly enumerated in this Article 11, and those that may in any manner apply with respect to the performance of the Concessionaire's obligations under this Agreement. For the avoidance of doubt, any costs incurred to comply with applicable Law as a result of any Capital Improvement or other alteration to the Utility System undertaken by the Concessionaire, shall be at the Concessionaire's cost (subject to inclusion in the Utility Fee as part of the Variable Fee Component or Uncapped O&M Costs or as part of the Capped O&M Index, as applicable). The Concessionaire shall notify the University within 7 Days after receiving written notice from a Governmental Authority that the Concessionaire or the Operator may have violated any Laws. Pursuant to Idaho Code section 67-2359, the Concessionaire certifies that it is not currently owned or operated by the government of China and will not for the duration of the Contract be owned or operated by the government of China. The terms in this section defined in Idaho Code section 67-2359 shall have the meaning defined therein. The Concessionaire hereby certifies that: (i) pursuant to Idaho Code Section 67-2346, if payments under the Agreement exceed one hundred thousand dollars (\$100,000) and it employs ten (10) or more persons, it is not currently engaged in, and will not for the duration of the Agreement engage in a boycott of goods or services from Israel or territories under its control.

Section 11.2. Non-Discrimination.

- (a) *Non-Discrimination Requirements.* The Concessionaire shall comply with, and maintain employment policies in a manner consistent with, all applicable Laws regarding equal employment opportunity and non-discrimination in employment, including: (i) the Civil Rights Act of 1964, 42 U.S.C. § 2000 *et seq.* (1981); (ii) the Civil Rights Act of 1991, P.L. 102-166; (iii) Executive Order Number 11246, 30 Fed. Reg. 12,319 (1965), reprinted in 42 U.S.C. § 2000(e) note, as amended by Executive Order Number 11375, 32 Fed. Reg. 14,303 (1967) and by Executive Order Number 12086, 43 Fed. Reg. 46,501 (1978); (iv) the Age Discrimination Act, 42 U.S.C. §§ 6101-6106 (1981); (v) the Age Discrimination in Employment Act, 29 U.S.C. §§ 621-34 (1967); (vi) the Rehabilitation Act of 1973, 29 U.S.C. §§ 793-794 (1981); (vii) the Americans with Disabilities Act, 42 U.S.C. § 12101 *et seq.* (1990); (viii) the Uniformed Services Employment and Reemployment Rights Act, 38 U.S.C. § 4301 *et seq.*; and (ix) the Idaho Human Rights Act, Idaho Code Sec. 67-5901 *et seq.*
- (b) *Contract Provisions.* The Concessionaire shall cause all Contractors to comply with each of the federal Laws and Idaho Laws referenced in this Section 11.2, and shall include a provision to such effect in each contract entered into with any Contractor.

Section 11.3. Compliance with Wage and Hour Laws. The Concessionaire shall comply with all applicable Laws governing employment and/or employee wages and hours, including (i) the Fair Labor Standards Act, 29 U.S.C. § 201 *et seq.*; (ii) the Idaho Minimum Wage Law, I.C. Sec 44-1501, *et seq.*; and (iii) the Idaho Claims for Wages Act, I.C. Sec. 45-601, ~~et seq.~~

Section 11.4. Safety Laws. The Concessionaire shall comply with and maintain employment policies in a manner consistent with all applicable Laws regarding workplace safety, including the Occupational Safety and Health Act of 1970, 29 U.S.C. § 651 *et seq.*

Section 11.5. Immigration Laws. The Concessionaire shall comply with and maintain employment policies in a manner consistent with all applicable Laws regarding lawful employment of U.S. citizens and non-U.S. citizens, including taking reasonable steps to verify the employment eligibility of all employees as required under such Laws.

Section 11.6. Labor Disputes. The Concessionaire shall take all reasonable steps to resolve any alleged or actual labor dispute between it or the Operator and any representative of its or the Operator's employees; further, any work stoppage or strike resulting from such labor dispute shall not excuse the Concessionaire's performance under this Agreement. The Concessionaire shall use good faith efforts and take immediate steps to effect the limitation and/or removal, by lawful means, of any pickets or picketing that are the result of an alleged or actual labor dispute between it and any representative of its employees; provided however, if such pickets or picketing results in the obstruction of ingress or egress of any Public Way or University facility, the Concessionaire shall immediately seek injunctive relief to terminate such pickets or picketing that may be available under applicable Laws.

Section 11.7. Employee Conduct and Performance. The Concessionaire shall ensure that it and the Operator have workplace conduct policies for their employees providing services under this Agreement that are at least as stringent as substantially similar policies and enforcement provisions as those of the University's general policies for conduct in the workplace and are in accordance with Prudent Industry Practices. These policies shall include policies related to workplace behavior; anti-harassment; weapons; confidentiality; security and safety; possession of alcohol; illegal drugs or weapons in the workplace; violation of criminal statutes that have a direct relationship to work performed by the employee; negligent or incompetent performance of work hereunder; gross misconduct related to work; conduct or interactions with University employees, students or visitors that impair or prejudice the University or its relationship with such persons; and unsafe practices or work performance that create a risk of harm to the employee, other persons or property.

Section 11.8. Non-Collusion. By signing this Agreement, the Concessionaire duly swears, affirms and warrants that it is the contracting party, and that it has not, nor has any other member, employee, Representative, agent or officer of the firm, company, corporation or partnership represented by it, directly or indirectly entered into or offered to enter into any combination, conspiracy, collusion or agreement to receive or pay any sum of money or other consideration for the execution of this Agreement other than that which appears upon the face of [the Original Agreement](#) or this Agreement.

Section 11.9. Conflict of Interest. The Concessionaire certifies and warrants to the University that neither it nor any of its agents, Representatives or employees who will participate in any way in the performance of Concessionaire's obligations hereunder has or, for so long as any such person continues in such capacity, will have any conflict of interest, direct or indirect,

with the University during the performance of this Agreement, other than in respect of any disputes that may arise hereunder or in connection herewith.

Section 11.10. Drug-Free Workplace Certification. The Concessionaire hereby covenants and agrees to make a good faith effort to provide and maintain a drug-free workplace. The Concessionaire will give written notice to the University within 7 Days after receiving actual notice that the Concessionaire or an employee of the Concessionaire has been convicted of a criminal drug violation occurring in the Concessionaire's workplace.

Section 11.11. Minority-Owned and Women-Owned Business Enterprises. The Concessionaire shall use good faith efforts during the Term to obtain the participation of M.B.E./W.B.E. in its Utility System Operations, including requiring the Operator to participate in such programs. In order to demonstrate this good faith efforts commitment, the Concessionaire shall, and shall cause all Contractors to, complete and submit to the University such documentation and information as the University may reasonably request.

Section 11.12. University Accreditation. The Concessionaire shall ensure that the Utility System provides a sufficient quantity of Utilities in a timeframe sufficient such that the University, or any portion thereof, may maintain any third-party accreditation or other third-party standard of which the University has provided the Concessionaire notice prior to the Setting Date.

Section 11.13. Permits and Other Campus-Wide Authorizations. The Concessionaire acknowledges and agrees that, in connection with the Campus-Wide Permits: (i) the University will continue to be the "owner" identified in the Campus-Wide Permits during the Term; (ii) the Concessionaire will become the "operator" of permitted emission sources from the Utility System identified in the Campus-Wide Permits during the Term, to the extent applicable; (iii) the Concessionaire shall be responsible for operating all emission sources in compliance with all permit and regulatory requirements and meeting all monitoring, recordkeeping and reporting requirements related to such permitted emission sources; (iv) the Concessionaire shall promptly provide to the University's Office of Environmental Health and Safety, as the responsible University official for communications with the State of Idaho, Division of Environmental Quality ("DEQ"), all records that the DEQ inspectors request the University provide with respect to the Utility System; and (v) the Concessionaire shall provide to the University (a) complete drafts of all required reports with respect to the Utility System portion of the Campus-Wide Permits for the University to review and Approve at least 15 Business Days prior to the deadline to submit such reports, (b) any information regarding utility operations required for reports related to the Campus-Wide Permits by the later of (1) 10 Days after the end of the applicable reporting period and (2) (A) 30 Days prior to the applicable submission deadline or (B) 10 Days after a University request not related to a submission deadline, (c) information to be submitted in connection with the renewal of the regulatory permits or any portion thereof within the time period reasonably established by the University and (d) applications for new permits or modifications to any Campus-Wide Permit for review and Approval at least 30 Days prior to submission to a regulatory agency; and (v) the Parties shall reasonably cooperate with each other in connection with any matters relating to the Campus-Wide Permits. The Concessionaire shall comply with all Campus-Wide Permits to the extent applicable to the Utility System or Utility System Operations, provided that the Concessionaire shall not be responsible for ensuring

compliance with the storm water permit for the municipal separate storm sewer system on the University Campus issued by the U.S. Environmental Protection Agency (“EPA”) (as may be extended, renewed, modified or replaced) to the extent related to Utility System Operations performed outside of the Utility Facilities or Utility System Land.

Section 11.14. Financial and Audit Standards. The Concessionaire shall comply, and its financial statements shall be prepared in accordance, with GAAP or IFRS, provided that if such financial statements are prepared in accordance with IFRS, such financial statements shall include a reconciliation statement setting forth any material discrepancies between IFRS and GAAP reporting with respect to the subject matter thereof.

Section 11.15. University Payments. All financial obligations of the University under this Agreement are payable solely from the then-current revenues of the University legally available for such purpose and the Concessionaire shall have no right to receive payment from moneys raised by taxation or state appropriations. The failure of the University to comply with its financial obligations hereunder shall not preclude the Concessionaire from bringing a claim therefor pursuant to the express provisions hereof.

ARTICLE 12 PAYMENT OBLIGATIONS

Section 12.1. Certain Payment Obligations of the Concessionaire. To the extent permitted by Law, the Concessionaire shall have a payment obligation to the University and each of its Representatives with respect to the full amount of any Losses actually suffered or incurred (as they are suffered or incurred) by the University or any such Representative, based upon, arising out of, related to, occasioned by or attributable to (i) any failure by the Concessionaire, the Operator or each of their respective Representatives to comply with, observe or perform any of the covenants, obligations, agreements, terms or conditions in this Agreement or, subject to the expiration of the survival period specified in Section 9.4(b), any breach by the Concessionaire of its representations or warranties set forth herein, (ii) any Assumed Liabilities, (iii) any Tax or recording charge attributable to any Transfer of the Concessionaire Interest or any part thereof by the Concessionaire, (iv) any increase in Property Taxes payable by the University that is not included in the definition of Uncapped O&M Costs, or (v) any claim for brokerage commissions, fees or other compensation by any Person who acted on behalf of the Concessionaire or its Representatives in connection with this Agreement, any Transfer of the Concessionaire Interest or any part thereof or any other matter affecting the Utility System; provided, however, that, except with respect to Claims resulting from Third Party Claims, subject to Section 12.5 Claims shall be made in writing within a period of 3 Years following the expiration of the Term or earlier termination of this Agreement or within such shorter period as may be prescribed by the applicable statute of limitations. The Parties agree that the Representatives of the University are intended to be third party beneficiaries of the obligations of the Concessionaire pursuant to this Article 12.

Section 12.2. Certain Payment Obligations of the University. To the extent permitted by Law, and without limiting any other remedy under this Agreement (including Concession Compensation or AA-Compensation as provided in this Agreement) the University shall have a payment obligation to the Concessionaire and each of its Representatives with

respect to any Losses actually suffered or incurred by the Concessionaire or any such Representative, based upon, arising out of, related to, occasioned by or attributable to (i) any failure by the University or any of its employees, officers or agents (collectively, the “University Responsible Parties”) to comply with, observe or perform any of the covenants, obligations, agreements, terms or conditions in this Agreement or, subject to the expiration of the relevant survival period specified in Section 9.4(a), any breach by the University of its representations or warranties set forth herein, (ii) any Excluded Liabilities, (iii) any claim for brokerage commissions, fees or other compensation by any Person who acted on behalf of the University or any University Responsible Party in connection with this Agreement or any other matter affecting the Utility System, or (iv) any payment of Property Taxes with respect to the Utility System that are not the result of the actions or omissions of the Concessionaire and therefore not paid to the Concessionaire as Uncapped O&M Costs; provided, however, that, except with respect to Claims resulting from Third Party Claims, subject to Section 12.5, Claims are made in writing within a period of 3 Years following the expiration of the Term or earlier termination of this Agreement or within such shorter period as may be prescribed by the applicable statute of limitations. The Parties agree that the Representatives of the Concessionaire are intended to be third party beneficiaries of the obligations of University pursuant to this Article 12.

Section 12.3. Agency for Representatives. Each of the University and the Concessionaire agrees that it accepts each payment obligation contemplated in this Article 12 in favor of any of its Representatives as agent and trustee of that Representative and agrees that each of the University and the Concessionaire may enforce a payment obligation in favor of its Representatives on behalf of that Representative. For purposes of this Section 12.3, the term “Representative”, in the case of the Concessionaire, includes the Leasehold Mortgagee.

Section 12.4. Third Party Claims.

- (a) *Notice of Third Party Claim.* If an Obligee receives notice of the commencement or assertion of any Third Party Claim, the Obligee shall give the Obligor reasonably prompt notice thereof, but in any event no later than 30 Days after receipt of such notice of such Third Party Claim. Such notice to the Obligor shall describe the Third Party Claim in reasonable detail (and include a copy of any complaint or related documents) and shall indicate, if reasonably practicable, the estimated amount of the Loss that has been or may be sustained by the Obligee.
- (b) *Defense of Third Party Claim.* The Obligor may participate in or assume the defense of any Third Party Claim by giving notice to that effect to the Obligee not later than 30 Days after receiving notice of that Third Party Claim (the “Notice Period”). The Obligor’s right to do so shall be subject to the rights of any insurer or other Party who has potential responsibility with respect of that Third Party Claim. The Obligor agrees to pay all of its own expenses of participating in or assuming each defense. The Obligee shall cooperate in good faith in the defense of each Third Party Claim, even if the defense has been assumed by the Obligor and may participate in such defense assisted by counsel of its own choice at its own expense. If the Obligee has not received notice within the Notice Period that the Obligor has elected to assume the defense of

such Third Party Claim, the Obligee may assume such defense, assisted by counsel of its own choosing and the Obligor shall be responsible for all reasonable costs and expenses paid or incurred in connection therewith and any Loss suffered or incurred by the Obligee with respect to such Third Party Claim.

- (c) *Assistance for Third Party Claims.* The Obligor and the Obligee will use all reasonable efforts to make available to the Party which is undertaking and controlling the defense of any Third Party Claim (the “Defending Party”), (i) those employees whose assistance, testimony and presence is necessary to assist the Defending Party in evaluating and in defending any Third Party Claim, and (ii) all Documents, records and other materials in the possession of such Party reasonably required by the Defending Party for its use in defending any Third Party Claim, and shall otherwise co-operate with the Defending Party. The Obligor shall be responsible for all reasonable expenses associated with making such Documents, records and materials available and for all expenses of any employees made available by the Obligee to the Obligor hereunder, which expense shall not exceed the actual cost to the Obligee associated with such employees.
- (d) *Settlement of Third Party Claims.* If an Obligor elects to assume the defense of any Third Party Claim in accordance with Section 12.4(b), the Obligor shall not be responsible for any legal expenses subsequently incurred by the Obligee in connection with the defense of such Third Party Claim. However, if the Obligor fails to take reasonable steps necessary to defend diligently such Third Party Claim within 30 Days after receiving notice from the Obligee that the Obligee believes on reasonable grounds that the Obligor has failed to take such steps, the Obligee may, at its option, elect to assume the defense of and to compromise or settle the Third Party Claim assisted by counsel of its own choosing and the Obligor shall be responsible for all reasonable costs and expenses paid or incurred in connection therewith. However, the Obligee shall not settle or compromise any Third Party Claim without obtaining the prior written consent of the Obligor unless such settlement or compromise is made without any responsibility to, and does not require any action on the part of, the Obligor and does not in any way affect the Obligor. In the event that the Obligee is the University, in no event may the Obligor settle or compromise any Third Party Claim without obtaining the prior written consent of the Obligee.

Section 12.5. Direct Claims. Any Direct Claim shall be asserted by giving the Obligor reasonably prompt notice thereof, but in any event not later than 60 Days after the Obligee becomes aware of such Direct Claim. The Obligor shall then have a period of 30 Days within which to respond in writing to such Direct Claim. If the Obligor does not so respond within such 30-Day period, the Obligor shall be deemed to have rejected such Direct Claim, and in such event the Obligee may submit such Direct Claim to the dispute resolution process set forth in Article 18.

Section 12.6. Failure to Give Timely Notice. A failure to give timely notice in accordance with this Article 12 shall not affect the rights or obligations of any Party except and

only to the extent that, as a result of such failure, a Party which was entitled to receive such notice was deprived of its right to recover any payment under its applicable insurance coverage or was otherwise directly and materially damaged as a result of such failure. However, this Section 12.6 shall have no effect whatsoever on the survival provisions set out in Section 9.4 and the rights of the Parties with respect thereto.

Section 12.7. Reductions and Subrogation. If the amount of any Loss incurred by an Obligee at any time subsequent to the making of a payment hereunder on account of such Losses (an "Obligation Payment") is reduced by any recovery, settlement or otherwise under or pursuant to any insurance coverage, or pursuant to any claim, recovery, settlement or payment by or against any other Person, the amount of such reduction (less any costs, expenses (including Taxes) or premiums incurred in connection therewith), together with interest thereon from the date of such recovery, settlement or reduction at the Bank Rate, shall promptly be repaid by the Obligee to the Obligor. Upon making a full Obligation Payment, the Obligor shall, to the extent of such Obligation Payment, be subrogated to all rights of the Obligee against any third party in respect of the Loss to which the Obligation Payment relates. Until the Obligee recovers full payment of its Loss, any and all claims of the Obligor against any such third party on account of such Obligation Payment shall be postponed and subordinated in right of payment to the Obligee's rights against such third party.

Section 12.8. Payment and Interest. All amounts to be paid by an Obligor hereunder, not including deductibles or self-insured retentions or insurance proceeds, shall bear interest at a rate per annum equal to the Bank Rate, calculated annually and payable monthly, both before and after judgment, from the date that the Obligee disbursed funds, suffered damages or losses or incurred a loss or expense in respect of a Loss for which the Obligor is responsible to make payment pursuant to this Article 12, to the date of payment by the Obligor to the Obligee.

Section 12.9. Limitation on Certain Claims. To the extent permitted by Law and without limiting any other remedy under this Agreement (including Concession Compensation, AA-Compensation or KPI Compensation as provided in this Agreement), the maximum aggregate liability of the University to the Concessionaire or its Representatives, in respect of Losses pursuant to this Article 12 shall not exceed 50% of the Closing Consideration; provided further that this Section 12.9 shall not apply to Claims for: (i) breach of the representations or warranties in Sections 9.1(a), (b), (c), (d), (e), (f), (g), and (j); (ii) fraud, intentional misrepresentation or intentional breach of the representations or warranties in Section 9.1; (iii) for any Excluded Liabilities referred to in Section 3.2(d)(iii)(2); (iv) payment of the Utility System Concession Value; and (v) payment of the Utility Fee. To the extent permitted by Law and without limiting any other remedy under this Agreement, the maximum aggregate liability of the Concessionaire to the University and its Representatives, in respect of Losses pursuant to this Article 12 shall not exceed 50% of the Closing Consideration; provided further that this Section 12.9 shall not apply to Claims for the breach of the representations or warranties in Section 9.2(a), (b), (c), (d), (e), (f), (g) and (j) or Section 12.1(iv) or to Claims for fraud, intentional misrepresentation or intentional breach of the representations or warranties in Section 9.2. Neither Party shall have any liability to the other Party or its Representatives for Losses to the extent resulting from fraudulent actions or gross negligence of the other Party or its Representatives (or University Responsible Parties in the case of the University).

Section 12.10. Other Matters.~~—~~—

- (a) *Waiver of Limits.* With respect to claims by the Concessionaire’s employees, the Concessionaire waives its immunity, if any, to which it is entitled or would be entitled, as a complying employer under the applicable worker’s compensation law, but only to the extent that such immunity would bar or affect recovery under or enforcement of Concessionaire’s obligations to defend, indemnify, hold harmless or contribute to any sums due under any Losses.
- (b) *Losses Net of Insurance.* For purposes of this Article 12, the amount of any Losses for which payment is provided hereunder shall be net of any amounts recovered by the Obligee under insurance policies with respect to such Losses, it being understood that the obligations of the Obligee hereunder shall not be so reduced to the extent that any such recovery results in an increase in the Obligee’s insurance premiums, or results in any other additional cost or expense to any such Obligee.

Section 12.11. Offset Rights; Limitations on Certain Damages.~~—~~—

- (a) Each Party’s obligations under this Agreement are subject to, and each Party shall have the benefit of, all defenses, counterclaims, rights of offset or recoupment or other claims and rights, including the right to deduct payments due to the other Party hereunder that are not subject to dispute (collectively, “Offsets”) which such Party may have at any time against such other Party (or any of their respective successors and assigns) or any transferee or assignee of any such other Party’s rights as against such Party or any part thereof or interest therein contingent or otherwise, and no transfer or assignment of this Agreement or any other obligation of such other Party, or of any rights in respect thereof, pursuant to any plan of reorganization or liquidation or otherwise shall affect or impair the availability to each Party of the Offsets.
- (b) In no event shall any Party be liable to the other Party under this Agreement for consequential, indirect, exemplary or punitive damages (except for claims for fraud or for intentional misrepresentation or intentional breach).

Section 12.12. Governmental Immunity. Notwithstanding anything herein to the contrary, the Parties acknowledge and agree that the University and its officers, employees, and agents are relying on, and do not waive or intend to waive by any provision of this Agreement, the monetary limitations or any other rights, immunities, and protections provided by the Idaho Tort Claims Act, Idaho Code Section 6-901 *et seq.*, or otherwise available to the University and its officers, employees, and agents.

Section 12.13. Survival. This Article 12 shall remain in full force and effect in all circumstances and shall not be terminated by any breach (fundamental, negligent or otherwise) by any Party of its representations, warranties or covenants hereunder or by any termination or rescission of this Agreement by any Party.

**ARTICLE 13
INSURANCE**

Section 13.1. Insurance Coverage Required – Concessionaire. The Concessionaire shall provide and maintain at the Concessionaire’s own expense, or cause to be maintained, during the Term and during any time period following expiration if the Concessionaire is required to return and perform any additional work, commercially reasonable insurance coverage in accordance with Prudent Industry Practices, including, at a minimum, the insurance coverages and requirements specified below, insuring the Utility System and all Utility System Operations (the “Concessionaire Required Coverages”). For the avoidance of doubt, Concessionaire Required Coverages may be provided and maintained as part of a corporate insurance program of a direct or indirect holder of equity in the Concessionaire and each of the insurance coverage limits set out in Section 13.1(b), Section 13.1(c) and Section 13.1(d) may be achieved through a combination of primary, excess and/or umbrella coverage.

- (a) *Workers’ Compensation and Employer’s Liability.* The Concessionaire shall provide or cause to be provided Workers’ Compensation Insurance, to cover liability imposed by Federal and State statutes having jurisdiction over the Concessionaire’s employees engaged in the performance of this Agreement and Employer’s Liability Insurance coverage with limits of not less than \$1,000,000 each employee and \$1,000,000 for each accident.
- (b) *Commercial General Liability.* The Concessionaire shall provide or cause to be provided Commercial General Liability Insurance or equivalent with limits of not less than \$1,000,000 per occurrence and \$2,000,000 in the annual aggregate. Coverage shall include the following: bodily injury and property damage including personal injury, coverage for contractual employees (excluding any employees of the University), all premises and operations, including blanket contractual and products/completed operations, explosion, collapse, mobile equipment not suitable for roadways, underground, separation of insureds, and liability assumed under an insured contract and shall be written on ISO form CG 00 01 04 13 or its equivalent.
- (c) *Commercial Automobile Liability.* When any motor vehicles (owned, non-owned or hired) are used in connection with work to be performed, the Concessionaire shall provide or cause to be provided Commercial Automobile Liability Insurance with limits of not less than \$1,000,000 combined single limit each accident for bodily injury and property damage. The policy shall be endorsed with CA 99 48 and MCS 90 (or their equivalents), if such exposure exists.
- (d) *Umbrella Liability.* The Concessionaire shall provide or cause to be provided follow form Umbrella Liability Insurance with a minimum limit of \$50,000,000 per occurrence and shall apply in excess of the coverages for the Concessionaire Required Coverages set forth in Section 13.1(a), Section 13.1(b) and Section 13.1(c). In the event that such Umbrella Liability Insurance applies in excess of the coverages for the Concessionaire Required Coverage in Section 13.1(e), then

the minimum limit for the Concessionaire Required Coverage in Section 13.1(e) shall be \$12,000,000 rather than \$15,000,00, and in the event that such Umbrella Liability Insurance applies in excess of the coverages for the Concessionaire Required Coverage in Section 13.1(g), then the minimum aggregate limit for the Concessionaire Required Coverage in Section 13.1(g) shall be \$10,000,000 rather than \$15,000,000.

- (e) *Professional Liability.* When any architects, engineers, construction managers, professional services providers or any other professional consultants perform work in connection with this Agreement, the Concessionaire shall maintain or require such architects, engineers, construction managers or other professional consultants to maintain Professional Liability Insurance, with limits not less than \$15,000,000 per claim and in the aggregate or such other limit (whether lower or higher) as the University and the Concessionaire may agree (each, acting reasonably) with respect to such policy for a particular Capital Improvement or Material Change, which other limit shall be included as part of the Approval of such Capital Improvement or Material Change in accordance with Section 4.3. The policy shall include: contingent bodily injury liability, rectification and punitive damages. The faulty workmanship exclusion should be modified to cover losses arising out of professional services. Should the Concessionaire self-perform any work of the nature noted in this Section 13.1(e), evidence of Professional Liability Insurance meeting the standards for such work set forth above shall be required.
- (f) *Network Security and Privacy Insurance.* The Concessionaire shall also maintain Cyber Liability Insurance for network security and privacy with limits of not less than \$10,000,000 per claim and in the aggregate inclusive of cybersecurity event management. When policies are renewed or replaced, the policy retroactive date shall coincide with, or precede, start of work in connection with this Agreement.
- (g) *Pollution Legal Liability.* The Concessionaire shall provide Pollution Legal Liability Insurance or Site Pollution Insurance or cause to be provided Pollution Legal Liability Insurance or Site Pollution Insurance or equivalent, in each case with limits of not less than \$10,000,000 per incident and \$15,000,000 in the aggregate during any 3 year period for environmental and pollution damage liability arising out of pollution events occurring after the Closing Date.
- (h) *Property.* The Concessionaire shall obtain All Risk Property Insurance at full replacement cost, covering all loss, damage or destruction to the Utility System (including improvements and betterments and excluding any building in which the Shared Spaces are located), which insurance may be provided on a blanket basis with reported building values, which shall include the value of the coverage for the Utility System; provided, however, that the limits of such coverage may be based on replacement cost value agreed by the University and the Concessionaire acting reasonably or on a probable maximum loss analysis, subject to the University's Approval of such probable maximum loss analysis by an independent third party that is reasonably acceptable to the University.

Coverage shall include the following, but not be limited to: equipment breakdown, collapse, water including overflow, leakage, sewer backup or seepage, utility interruption, debris removal, business ordinance or law for increased cost of construction, extra expense, boiler and machinery, valuable papers and, to the extent commercially available, earthquake and named wind. Coverage shall include flood insurance with a sublimit of not less than \$10,000,000 in the aggregate. The University and any Leasehold Mortgagee shall be named as additional insureds and as loss payees. The Concessionaire shall be responsible for any loss or damage to University property caused by the Concessionaire or its Representatives at full replacement cost, except to the extent such loss or damage is covered by the insurance described in Section 13.2(c), in which case the Concessionaire shall be responsible for the deductible only in accordance with Section 13.2(c).

- (i) *Builder's Risk.* When the Concessionaire undertakes, pursuant to this Agreement, any construction, maintenance or repairs to the Utility System (including Capital Improvements, Material Changes and betterments), the Concessionaire shall provide or cause to be provided, All Builder's Risk Insurance at replacement cost for materials, supplies, equipment, machinery and fixtures that are or will be part of the Utility System. Coverage shall include, but not be limited to, the following: right to partial occupancy, boiler and machinery, business income, valuable papers and other consequential loss, when applicable with aggregate ~~sublimits~~sub-limits for catastrophic perils of earthquake, flood and named wind which are the best available on commercially reasonable terms. The Concessionaire and any Leasehold Mortgagee may be named as additional insured and as loss payees.

Section 13.2. Insurance Coverage Required – University. The University shall provide and maintain at the University's own expense, or cause to be maintained, during the Term and during any time period following expiration if the Concessionaire is required to return and perform any additional work, the following insurance coverages and requirements specified below (the "University Required Coverages" together with the Concessionaire Required Coverages, the "Required Coverages").

- (a) *Workers' Compensation.* The University shall provide or cause to be provided Workers' Compensation coverage, as prescribed by applicable Law, covering all University employees who agree to provide a service under this Agreement.
- (b) *University Liability Coverage.* The University's liability coverage is self-funded and administered by the State of Idaho Risk Management Program. The University's liability is subject to the limitations in the Idaho Tort Claims Act, Idaho Code, §§ 6-901 – 6-929, for liability covered by the Idaho Tort Claims Act. The total liability for any one occurrence or accident under the Idaho Tort Claims Act and State of Idaho Risk Management Program is \$500,000. ~~The Concessionaire shall be included as an additional interest under this coverage.~~ Additionally, the University is covered for data

loss or breach through a policy maintained by the Idaho Office of Insurance Management.

- (c) *Property.* The University shall obtain All Risk Property Insurance at full replacement cost, covering all loss, damage or destruction to the University's owned property (other than any property leased to the Concessionaire hereunder), including improvements and betterments and the buildings in which the Shared Spaces are located, which insurance may be provided on a blanket basis with reported building values, which shall include the value of the coverage for the University's owned property required hereunder; provided, however, that the limits of such coverage may be based on replacement cost value. Coverage shall include the following: equipment breakdown, collapse, water including overflow, leakage, sewer backup or seepage, utility interruption, debris removal, business ordinance or law for increased cost of construction, extra expense, boiler and machinery, valuable papers and, to the extent commercially available, earthquake and named wind. Coverage shall include flood insurance with limits which are commercially available. The Concessionaire shall be responsible for the property deductible payable by the University and/or the State of Idaho for any loss or damage to University property caused by the Concessionaire or its Representatives.

Section 13.3. Additional Requirements.

- (a) *Evidence of Insurance.* The Parties shall deliver or cause to be delivered to each other's Representative designated in writing by each Party, original standard ~~ACCORD~~ ACCORD form Certificates of Insurance, or equivalent documentation acceptable to the Parties, evidencing the Concessionaire Required Coverages or University Required Coverages, as applicable, on or before the Closing Date, and shall provide or cause to be provided, promptly following renewal and not more than ~~14~~30 Business Days following renewal of the then current coverages (or such other period as is agreed to by the Parties), Renewal Certificates of Insurance, or such similar evidence, if such coverages have an expiration or renewal date occurring during the Term. The receipt of any certificate does not constitute agreement by the receiving party that the insurance requirements in this Agreement have been fully met or that the insurance policies indicated on the certificate are in compliance with all requirements of this Agreement. The failure of either Party to obtain certificates or other insurance evidence from the other Party shall not be deemed to be a waiver by such Party. Non-conforming insurance shall not relieve either Party of the obligation to provide insurance as specified herein.
- (b) *Notice of Cancellation or Violation.* Each Party shall notify the other Party in writing 30 Days (or in the case of cancellation for non-payment of premiums, 10 Days) prior to cancellation, non-renewal or any material change of any University Required Coverages (in the case of the University) or Concessionaire Required Coverages (in the case of the Concessionaire). Without limiting Section 13.3(g), the University shall be permitted (but not obligated) to pay any

delinquent premiums before the cancellation date specified by the insurer in any notice of cancellation for non-payment of premium in order to maintain such coverage in full force and effect and the Concessionaire shall reimburse the University for any delinquent premiums paid by the University on demand without any Days of grace and without prejudice to any other rights and remedies of the Parties hereunder.

- (c) *Deductibles.* All deductibles or self-insured retentions for Concessionaire Required Coverages or Concessionaire Contractors in excess of \$200,000 (Adjusted for Inflation annually starting from the Year in which the Closing occurred) shall not exceed amounts approved by the University in writing. Except as expressly provided herein, any and all deductibles or self-insured retentions on Required Coverages shall be borne by the purchasing Party or its Contractors, who shall be responsible for its own deductibles and/or self-insured retentions unless the Party is at fault for a loss to the other Party in which case the at fault party will pay the other Party's deductible or self-retention.
- (d) *Post-Termination Effectiveness.* The products/completed operations portion of the Concessionaire's Commercial General Liability Insurance shall be continued for at least 5 years following the termination of this Agreement and evidence of such insurance shall be provided to the University at least annually.
- (e) *Adjustment of Insurance Coverages.* The amounts of coverage required by Section 13.1 and Section 13.2 shall be reasonably adjusted, as agreed by the University and the Concessionaire, based on limits maintained for comparable property each succeeding fifth anniversary of the Closing Date, but in no event shall the amounts of coverage be less than specified in Section 13.1 and Section 13.2.
- (f) *Waiver of Subrogation.* Each of the Required Coverages provided by either Party (other than those set forth in Section 13.2(a) and Section 13.2(b)) shall, where legally or customarily permitted, include a waiver by the insurer of its rights of subrogation against the other, its employees, elected officials, agents or Representatives (and, in the case of the Concessionaire Required Coverages, against the State of Idaho; the University, their agents, officials, and employees. Concessionaire shall cause each of its Contractors to waive all their rights of subrogation against the State of Idaho; the University, their agents, officials, and employees.
- (g) *University's Right to Insure.* Without limiting Section 13.3(b), if the Concessionaire fails to obtain and maintain or cause to be obtained and maintained the Concessionaire Required Coverage in accordance with this Article 13, the University shall have the right (without any obligation to do so), upon 2 Business Days' notice to the Concessionaire in a non-emergency situation or forthwith in an emergency situation and without assuming any obligation in connection therewith, to effect such insurance and all costs and expenses in connection therewith shall be payable by the Concessionaire on

demand without any Days of grace and without prejudice to any other rights and remedies of the University hereunder. Such insurance taken out by the University shall not relieve the Concessionaire of its obligations to insure hereunder and the University shall not be liable for any loss or damage suffered by the Concessionaire in connection therewith.

- (h) *No Limitation as to Concessionaire Liabilities.* The Concessionaire expressly understands and agrees that any coverages and limits furnished by the Concessionaire shall in no way limit the Concessionaire's liabilities and responsibilities specified within this Agreement or by Law.
- (i) *No Contribution by University.* The Concessionaire expressly understands and agrees that any insurance or self-insurance programs maintained by the University, [State Risk](#) or the State of Idaho shall not contribute with insurance [actually](#) provided by the Concessionaire under this Agreement.
- (j) *Insurance Requirements of Contractors.* The Concessionaire shall require in each contract with any Contractor that such Contractor obtain coverages reasonably comparable to the Concessionaire Required Coverages that are reasonably appropriate in their limits and other terms and conditions, in each case to the nature of the contract with the Contractor. Such coverages shall insure the interests of the State of Idaho, the University, their agents, officials, and employees (provided that such agents, officials or employees shall not be included if not permitted by applicable Law or commercially available), the Concessionaire and any other Contractors in respect of the applicable work being performed and shall be subject to the same (or comparable) coverage and administrative requirements as are imposed on the Concessionaire pursuant to this Agreement, specifically requiring such Contractor to name the State of Idaho, the University, their agents, officials and employees as additional insured and requiring such Contractor's insurance to include a waiver of subrogation as described in [Section 13.3\(f\)](#). When requested to do so by the University, the Concessionaire shall provide, or cause to be provided, to the University Certificates of Insurance with respect to such insurance coverages or such other evidence of insurance, as may be reasonably acceptable in form and content to the University.
- (k) *Cooperation.* The University and the Concessionaire shall do all acts, matters and things as may be reasonably necessary or required to expedite the adjustment of any loss or damage covered by insurance hereunder so as to expedite the release and dedication of proceeds of such insurance in the manner and for the purposes herein contemplated.
- (l) *Joint Venture and Limited Liability Company Policies.* If the Concessionaire or any Contractor required to obtain an insurance policy hereunder is a joint venture or limited liability company, all insurance policies required to be obtained by the Concessionaire or such Contractor shall specifically name the joint venture or limited liability company as a named insured. If the

Concessionaire contracts operations to a third party, the Concessionaire will be an additional insured on any liability policy.

- (m) *Other Insurance Obtained by Concessionaire.* If the Concessionaire or its Contractors desire coverages in addition to the Concessionaire Required Coverages, the Concessionaire and each Contractor shall be responsible for the acquisition and cost of such additional coverages. If the Concessionaire or its Contractors obtain any property, liability or other insurance coverages that will relate to the Utility System or the Utility System Operations in addition to the Concessionaire Required Coverages (“Additional Coverages”), then the Concessionaire or its Contractors shall (i) notify the University as to such Additional Coverages at least 10 Business Days in advance of purchasing such Additional Coverages and make such modifications as the University may reasonably require so that such Additional Coverage does not conflict with the University’s insurance coverages, (ii) provide the University with any documentation relating to the Additional Coverages, including Certificates of Insurance, that the University reasonably requests, and (iii) at the University’s election, acting reasonably, cause the State of Idaho, the University, their agents, officials and employees, to be named as additional insureds under such Additional Coverages, if that is normally allowed in accordance with good industry practice.
- (n) *University’s Right to Modify.* The University shall have the right, acting reasonably, to request to modify, delete, alter or change insurance coverage requirements set forth in Section 13.1 and this Section 13.3. Notwithstanding anything to the contrary herein, ~~(i) any change to the types or limits of contractually required insurance coverage shall be subject to mutual agreement of the Parties, each acting reasonably, and (ii) if any insurance (including the limits or deductibles thereof) required to be maintained under this Agreement shall not be available at commercially reasonable rates, the Concessionaire’s obligation to obtain or maintain such insurance shall be waived by the University for as long as such insurance shall not be available at commercially reasonable rates, provided that during the period of such waiver, the Concessionaire maintains the maximum amount of such insurance otherwise available at commercially reasonable rates.~~
- (o) *Commercial Availability.* To the extent any of the Required Coverages are not available on a commercially reasonable basis (including, without limitation, not available at a commercially reasonable cost) or on commercially reasonable terms, the obligation of the Party responsible for obtaining such Required Coverage is waived and such Party shall obtain insurance that is available on a commercially reasonable basis or on commercially reasonable terms that best approximates the applicable Required Coverages, subject to Section 13.3(u), but said substitute coverage shall, at the other Party’s request, be subject to review of an independent insurance consultant, and such independent insurance consultant shall have delivered to the University and the Concessionaire its opinion to the effect that the substitute coverages meet the above-stated criteria. To the extent

the University disagrees with the Concessionaire's determination that the Concessionaire Required Coverages, including Required Property Insurance, for all or a portion of the Utility System is not commercially available in accordance with Section 13.3(o), then such disagreement shall be resolved in accordance with Article 18. For any Fiscal Year that the Concessionaire reasonably determines that such Concessionaire Required Coverages may not be commercially available, the Concessionaire agrees that it shall undertake diligent, good faith, commercially reasonable efforts to procure the Concessionaire Required Coverages, including Required Property Insurance, provided that the Concessionaire shall not be required to seek such coverage in the insurance market more than once per Fiscal Year if it reasonably determines that seeking coverage more than once per Fiscal Year would be detrimental to the Concessionaire's ability to seek coverage in future Fiscal Years.

- (p) *Endorsements.* All Concessionaire Required Coverages (except for the professional liability, workers' compensation and employer's liability policies) shall be endorsed to include the State of Idaho, the University, their agents, officials, and employees as additional insureds, in each case to the extent permitted by Law and commercially available. For the avoidance of doubt, Blanket Additional Insured endorsements that provide coverage "where required by contract" shall be acceptable for this purpose.
- (q) *Concessionaire Required Coverage Requirements.* All Concessionaire Required Coverages and the University's All Risk Property Insurance described in Section 13.2(c) shall be issued by reputable insurance companies duly authorized to engage in the insurance business in the State of Idaho, with an A.M. Best's rating of A-, VII or better; be primary noncontributory coverage and contain severability of interests provisions.
- (r) *Defense of Coverage Outside Limits of Liability.* All Concessionaire Required Coverages shall include defense coverage outside the limits of liability, except for the Professional Liability Insurance required to be carried by the Concessionaire.
- (s) *Requirements for Concessionaire Required Coverages for Liability Policies.* All Concessionaire Required Coverages that are liability policies shall be occurrence-based, except where not commercially available, in which case they shall be on a claims-made basis, provided that such policies shall extend for a period of 5 years after the expiration or earlier termination of this Agreement, which obligation shall survive the expiration or earlier termination of this Agreement.
- (t) *Payment for Insurance Coverage.* To the extent that the University and the Concessionaire determine that it would be in the best interests of both Parties for any of the Concessionaire Required Coverages to be purchased by and held in the name of the University, then the University shall be responsible for purchasing those certain Concessionaire Required Coverages, which shall satisfy

the Concessionaire's obligation to do so hereunder. The University shall name the Concessionaire and the Leasehold Mortgagee as additional insureds thereunder.

(u) *Commercial Unavailability of Required Property Insurance.*

- (i) The Concessionaire shall, as part of the first draft of each Five-Year Plan delivered to the University in accordance with Section 7.2, indicate if the property insurance for the Utility System described in Section 13.1(h) (the "Required Property Insurance") may not be commercially available as described in Section 13.3(o) for some or all of the Utility System as required hereunder and identify with reasonable detail the portions of the Utility System for which it believes the Required Property Insurance may not be commercially available for the upcoming Fiscal Year. The Concessionaire shall, in connection with such first draft of each Five-Year Plan, for all then in-force Required Property Insurance that is set to expire during the next Fiscal Year, provide to the University in writing a reasonably detailed status report of the Concessionaire's efforts that it has taken and expects to undertake, to renew such Required Property Insurance and the result of such efforts it reasonably expects in procuring such renewal.
- (ii) If the Parties agree that any Required Property Insurance is, or is going to be, commercially unavailable for a Fiscal Year in accordance with Section 13.3(o), then, promptly after such determination, the University and the Concessionaire shall reasonably cooperate in good faith on determining alternative methods of providing the Required Property Insurance, including by means of the University or State Risk providing such insurance or the University retaining the risk of damage for some portions of the Utility System at the Concessionaire's cost, not to be recovered as Capped O&M Costs or otherwise reimbursed or paid by the University. To the extent that State Risk provides any of the Required Property Insurance, the premium shall be in the amount of the Valuation Amount of Applicable Utility System Property multiplied by a certain rate as determined by State Risk, which for the avoidance of doubt is expected to be consistent with the cost being charged by State Risk to the University for property insurance that is not the Utility System. For the avoidance of doubt, the Valuation Amount of Applicable Utility System Property shall not be subject to dispute resolution in accordance herewith, but to the extent such Valuation Amount of Applicable Utility System Property changes by more than 10% in any Fiscal Year (without a corresponding change in the property covered thereby), the University shall reasonably cooperate, at no out-of-pocket cost to the University, to comply with State Risk's procedures, if any, available to request a reconsideration of such determination.

(iii) If, at the start of the applicable Fiscal Year, there is Uninsured Utility System Property, the Concessionaire shall, prior to the start of the applicable Fiscal Year, deliver notice to the University itemizing in reasonable detail all portions of the Utility System that are Uninsured Utility System Property, which shall be subject to verification and dispute by the University pursuant to Article 18, but otherwise shall be conclusive as against the Concessionaire for the Uninsured Utility System Property during such Fiscal Year provided that the University may within 30 Days after receipt of such notice, deliver notice to the Concessionaire that the University is excluding some or all of such portion of the Utility System from the definition of Uninsured Utility System Property for that Fiscal Year, in which case if a casualty event were to occur and affect such property, such casualty would be classified as a Concessionaire Retained Casualty. At the start of any Fiscal Year where there is Uninsured Utility System Property, the Concessionaire shall pay the University an amount equal to \$0.1885 per every \$100 of the Valuation Amount of Applicable Utility System Property for the relevant Uninsured Utility System Property for that Fiscal Year (such rate, the “URRAP Rate”), payable in equal monthly installments at the start of each month, provided, however, that such amount shall never be less than \$30,000 (such minimum amount, the “URRAP Floor” and such actual amount, the “University Retained Risk Annual Payment”), to compensate the University for the fact that there is Uninsured Utility System Property, provided that, if at any point during such Fiscal Year, the Concessionaire procures the Required Property Insurance such that there is no Uninsured Utility System Property, then no further University Retained Risk Annual Payment shall be payable for the remainder of the Fiscal Year while there is no Uninsured Utility System Property. Notwithstanding the foregoing, (x) the University, in its reasonable discretion and in good faith, shall have the right to adjust the URRAP Floor each applicable Fiscal Year, taking into consideration its anticipated administrative and legal costs associated with the Uninsured Utility System Property, provided that, in no event may the increase from the previous Fiscal Year exceed 100% for the URRAP Floor, (y) the URRAP Rate may be adjusted each applicable Fiscal Year by the University’s actuary, acting in good faith, and (z) if (A) the University Retained Risk Annual Payment increases by more than 25% from the preceding Fiscal Year’s University Retained Risk Annual Payment (Adjusted for Inflation) or (B) the Concessionaire obtains an independent valuation of the uninsured assets which is 25% less than the Valuation Amount of Applicable Utility System Property for the relevant Uninsured Utility System Property for that Fiscal Year, then by written notice to the University, the Concessionaire may elect not to pay the University Retained Risk Payment for such Fiscal Year and therefore, if a casualty event were to occur and affect such property, such casualty would be classified as a Concessionaire Retained Casualty.

Section 13.4. Damage and Destruction.

- (a) Notification; Emergent and Estimate Obligations of Concessionaire. If all or any part of any of the Utility System shall be destroyed or damaged during the Term in whole or in part by fire or other casualty of any kind or nature (including ~~any casualty for which insurance was not obtained or obtainable~~ with respect to Uninsured Utility System Property), ordinary or extraordinary, foreseen or unforeseen, ~~the Concessionaire shall~~ then:
- (i) the Concessionaire shall give the University notice thereof promptly after the Concessionaire receives actual notice of such casualty and shall undertake such steps as reasonably necessary to address any Emergency caused thereby;
- (ii) the Concessionaire shall, within thirty (30) Days after such casualty, provide to the University (A) its determination as to whether such casualty is (1) a Concessionaire Retained Casualty, (2) a State Risk Retained Casualty or (3) a University Retained Casualty and (B) its reasonable, good faith estimate based on a report provided by a licensed general contractor, architect, or engineer of the estimated cost of repairs, alterations, restorations, replacement and building to restore the part of the Utility System damaged or destroyed as a result of such casualty to its pre-loss condition, including (w) quotations and estimates from third party Contractors, (x) the timeframe for completion of the Restoration, (y) for a State Risk Retained Casualty or a University Retained Casualty only, any profit projected to be earned by the Operator or any other Contractor of the University, the Concessionaire, or the Operator that is responsible for such Restoration in whole or in part (i.e., such amount that will be earned by the Operator or any other Contractors in excess of the amount necessary for the Operator or applicable Contractor to pay for the Restoration, including payroll, materials, and other similar expenses), and (z) the impact on Utility System Operations of not performing such Restoration (the “Casualty Cost” and such estimates, the “Casualty Cost Estimate”); provided that, to the extent that the University disagrees with the Concessionaire’s assessment of the type of casualty in accordance with clause (A) above or the Casualty Cost Estimate (with respect to a University Retained Casualty only), the University shall provide the Concessionaire with notice thereof within thirty (30) Days after its receipt of the Casualty Cost Estimate (or such longer time as determined by State Risk, notice of which longer timeframe shall be provided to the Concessionaire) and provided further that the Parties acknowledge that State Risk’s determination of whether a casualty is a State Risk Retained Casualty shall be binding on both Parties;
- (iii) to the extent that the University disputes either the Casualty Cost Estimate or the classification of such casualty, in each case, in accordance with Section 13.4(a)(ii), then the University and the Concessionaire shall

resolve such disagreement in accordance with Article 18, provided that if the University does not Approve the Casualty Cost Estimate for a University Retained Casualty, rather than submit a dispute to the process described in Article 18, the University may perform, or cause a Contractor to perform, the Restoration for such University Retained Casualty. In such instance, the Concessionaire shall reasonably cooperate with the University and Contractor in connection therewith, including by providing access to the Utility System where reasonably necessary and, when such Restoration is complete, accept that restored portion as part of the Utility System in the same manner and subject to the same rights and obligations as if it were an Ongoing Utility System Project, except that, for the avoidance of doubt, (A) there shall be no Uncapped O&M Costs associated therewith if such Restoration is a like for like replacement without modification of the applicable Uninsured Utility System Property, (B) the Concessionaire shall not be entitled to include any costs incurred in connection with its obligations hereunder as a Capped O&M Cost or an Uncapped O&M Cost and shall not otherwise be entitled for reimbursement or payment from the University, and (C) the University shall either (1) assign to the Concessionaire a warranty for any defects in such Restoration that covers at least twelve (12) months after substantial completion thereof or (2) consider as a Delay Event any defect in such Restoration to the extent the Concessionaire provides notice thereof within twelve (12) months after completion of such Restoration and such defect is not caused by the use thereof by the Concessionaire or the Operator in a manner inconsistent with manufacturer recommendations or requirements;

(iv) within thirty (30) Days after delivery of the Casualty Cost Estimate, the University may also require that the Casualty Cost include modifications, including as to location or configuration, as directed by the University, provided (1) such modifications shall not materially and adversely affect the Concessionaire's ability to perform the Utility System Operations once completed and (2) any such modifications shall not increase the portion of the Casualty Cost Estimate borne by the Concessionaire unless such modifications are (A) approved in writing by the party other than the Concessionaire or the Operator responsible for its payment (State Risk or the University) or (B) treated as a Capital Improvement; and

(v) in the event that the Concessionaire's initial classification of a casualty is later changed pursuant to this Section 13.4(a) for any reason or upon mutual agreement of the Parties, the terms of this Section 13.4 shall apply to such newly classified casualty as if such casualty occurred on the date of such reclassification, except for with respect to the Casualty Cost Estimate thereof and the determination of when a Delay Event occurred.

(b) *Restoration Obligations of Concessionaire.* Following Approval of the Casualty Cost Estimate by the University, the Concessionaire shall:

(i) If the casualty is a Concessionaire Retained Casualty, the Concessionaire shall:

(~~ii~~A) at its sole cost and expense, whether or not insurance proceeds, if any, shall be equal to the ~~estimated cost of repairs, alterations, restorations, replacement and rebuilding~~ (the “Casualty Cost”) Estimate, which for the avoidance of doubt shall not be included in the Utility Fee, proceed diligently to repair, restore or rebuild the same to the condition existing prior to the happening of such fire or other casualty or with such modifications, including as to location or configuration, as directed by the University ~~provided such modifications shall not materially and adversely affect the Concessionaire’s ability to perform the Utility System Operations once completed and such cost shall be included in the Casualty Costs~~ (any such activity being a “Restoration”); and, provided that if there is an increase in Casualty Cost as a result of such University-directed modifications, the cost difference shall be the responsibility of, and reimbursed by, the University as either a Capital Improvement or as Uncapped O&M Costs; and

(~~iii~~B) deposit all insurance proceeds received by the Concessionaire in connection with any Restoration with the Depository selected by the University ~~pursuant to Section 13.4(b)~~; provided, however, that if at any time the Casualty Cost exceeds the net insurance proceeds actually deposited with the Depository, then the Concessionaire shall also deposit with the Depository such cash as is sufficient to cover the difference between the Casualty Cost and the net insurance proceeds deposited pursuant to this ~~Section 13.4(a)(iii) and Section 13.4(b)~~ (the “~~Restoration Shortfall Amount~~”), except to the extent such difference is caused by the negligence or willful misconduct of, or violation of applicable Law by, the University or is the result of any modifications made by the University pursuant to Section 13.4(a)(ii) in which case the University shall be responsible to make such deposit (collectively, with any interest earned thereon, the “Restoration Funds”).

(ii) If the casualty is a State Risk Retained Casualty:

(A) The Concessionaire shall reasonably assist the University, as requested by the University, in the University’s presentation (and the preparation thereof) of the Casualty Cost Estimate to State Risk for State Risk’s review and approval, including by providing such additional information related to the Casualty Cost Estimate as requested by the University, provided that if State Risk initially rejects such Casualty Cost Estimate and State Risk agrees that the University may revise its submission, the Concessionaire will reasonably cooperate with the University to submit a revised Casualty Cost Estimate until such time as the Casualty Cost Estimate is approved by State Risk or until such time as the claim is rejected by State Risk, provided that, for the avoidance of

doubt, if State Risk or State Risk's insurer reject any claim with respect to a State Risk Retained Casualty or State Risk determines that it is unwilling to submit a claim to State Risk's insurer related to a State Risk Retained Casualty (but the casualty affects the portion of the Utility System that is an insured asset under State Risk's insurance policy), then the Concessionaire shall be responsible for the costs of such Restoration and such casualty shall not become a University Retained Casualty, which for the avoidance of doubt shall not be included in the Utility Fee. In the event that any claim is either not submitted or rejected by State Risk or State Risk's insurer, as applicable, the University shall use reasonable efforts, at no cost to the University, to provide the Concessionaire with the rationale for such decision by State Risk or State Risk's insurer, provided that the University shall not be required to take any action that it reasonably and in good faith believes will harm its relationship with State Risk;

(B) The Concessionaire acknowledges that State Risk has the right to designate the Contractor that will perform any Restoration with respect to a State Risk Retained Casualty. If the Operator or any Contractor of the Concessionaire or the Operator is not selected to perform such Restoration, the Concessionaire agrees to reasonably cooperate with such Contractor and shall have the same rights and obligations with respect to such Restoration as it does with respect to an Ongoing Utility System Project. Without limiting the Concessionaire's right to request additional funds under Section 13.4(b)(ii)(D) (but acknowledging the Concessionaire has no unilateral right thereto), if the Operator or any Contractor of the Concessionaire or the Operator is selected to perform such Restoration, the Concessionaire shall cause such Restoration to be performed and completed with diligence regardless of the amount of insurance proceeds received from State Risk (including any additional funds provided pursuant to Section 13.4(b)(ii)(D)), which for the avoidance of doubt shall not be included in the Utility Fee;

(C) Once the Casualty Cost Estimate for the State Risk Retained Casualty is approved by State Risk (or earlier as required by State Risk), the Concessionaire shall pay the deductible required by State Risk for a State Risk Retained Casualty which, as of the date of execution of this Agreement does not exceed \$10,000;

(D) In the event that the University receives funds from State Risk in connection with a State Risk Retained Casualty and the Operator or any Contractor or the Concessionaire or the Operator is responsible for the Restoration, the University shall use those funds to pay the Concessionaire within thirty (30) Days after the later of (x) receipt of said funds from State Risk and (y) receipt by the University from the Concessionaire or the Operator of payment instructions for such funds, and in all instances such payment shall only occur after the deductible required by State Risk

has been paid by the Concessionaire, provided that, to the extent the cost of the Restoration exceeds the amount State Risk provides therefor, the Concessionaire shall be liable to fund such overage, which may not be recovered as part of the Utility Fee. If, prior to final adjustment of the claim, the Concessionaire determines in good faith that the Casualty Cost Estimate is less than the cost estimated to perform the Restoration and the Operator or a Contractor of the Concessionaire or the Operator is responsible for the Restoration, then the Concessionaire may submit an additional Casualty Cost Estimate during the claims adjustment period and request that the University request an increase in funds based on the additional Casualty Cost Estimate from State Risk, which is subject to approval of State Risk and the University makes no representation, warranty or guaranty that State Risk will agree to such increase, and if State Risk does not approve such increase, then the Concessionaire shall bear such additional cost in accordance herewith. The Concessionaire acknowledges and agrees that neither State Risk nor any insurer of State Risk shall waive any rights of subrogation either may have and that the Concessionaire shall not be an additional insured under any insurance policy held by State Risk.

(iii) If the casualty is a University Retained Casualty:

(A) The Concessionaire shall be responsible for the Restoration Funds up to the amount of the Maximum Retained Risk Payment and shall fund the same pursuant to Section 13.4(b)(iii)(B), and the Concessionaire shall proceed diligently to complete a Restoration for such casualty subject to Section 13.4(c); and

(B) The Concessionaire shall first fund the Restoration out of its own funds up to the amount of the Maximum Retained Risk Payment. Within five (5) Business Days after Approval of the Casualty Cost Estimate by the University, the Concessionaire will deposit the lesser of the (i) Casualty Cost Estimate and the (ii) Maximum Retained Risk Payment with a Depository. The Concessionaire shall provide the University with reasonable evidence of payment of such amount and the Restoration costs to which it was applied, which must be in strict accordance with the Casualty Cost Estimate. Notwithstanding the foregoing, to the extent that the Concessionaire provides evidence reasonably acceptable to the University of the Concessionaire's ability to fund the lesser of the (i) Casualty Cost Estimate and the (ii) Maximum Retained Risk Payment and the availability of such funds, the Concessionaire in each such case shall not be required to deposit such amount with the Depository, but may instead fund the same itself and shall provide the University with notice thereof. If the Concessionaire reasonably determines that the Casualty Cost will exceed the Casualty Costs identified in the Casualty Cost Estimate, then the Concessionaire shall promptly notify the University but unless Approved by the University, the excess shall be borne by the

Concessionaire and shall not be reimbursable as Uncapped O&M Costs or as part of the Utility Fee. Following exhaustion of the Maximum Retained Risk Payment if the Casualty Costs were in excess of the Maximum Retained Risk Payment, the University shall pay to the Concessionaire the remaining costs of the Restoration up to the Casualty Cost Estimate as follows: (1) either the University shall pay the Concessionaire on a monthly basis such remaining Restoration costs in accordance with Section 13.4(d); or (2) over twenty (20) years, payable on a semi-annual basis starting at the beginning of the Fiscal Year immediately following completion of such Restoration, which shall be paid in equal semi-annual installments, provided that, in addition to each annual payment, the University shall pay an interest charge equal to the Cost of Debt Factor (as defined in Schedule 5) that will accrue on the annual installments not yet paid (the “Long-Term Restoration Payment Plan”). The determination of the timing of payment shall be made by the University, in its sole discretion, at the time it approves the Casualty Cost Estimate. If the University elects the Long-Term Restoration Plan, the Concessionaire shall, within 30 Business Days after receipt of Notice of such election, either: (x) deposit with the Depository the full Casualty Costs identified in the Casualty Cost Estimate; or (y) provide to the University a performance bond or a letter of credit, in either case in the amount of the full Casualty Costs identified in the Casualty Cost Estimate and in a form reasonably acceptable to the University, provided that, for the avoidance of doubt, the election by the Concessionaire of either of the preceding clauses (x) or (y) shall not modify or alter the Concessionaire’s ultimate obligations and liabilities as it relates to Casualty Costs and completion of any Restoration as set forth herein. The Concessionaire acknowledges and agrees that, notwithstanding any payment of Restoration Funds in excess of the Maximum Retained Risk Payment by the University in connection with a University Retained Casualty, the University shall not waive any rights it has under this Agreement to make a claim against the Concessionaire or the Operator for negligence or breach or any other claim hereunder.

- (c) Rights of the University. Any Restoration undertaken pursuant to this Section 13.4 shall be undertaken in accordance with and subject to the terms of this Agreement. Prior to the commencement of Restoration work for a State Risk Retained Casualty or a University Retained Casualty, the Concessionaire shall submit to the University for Approval by the University the plans for the Restoration work consistent with the Approved Casualty Cost Estimate and such work shall not be undertaken unless the plans for such work have been Approved by the University (and State Risk, where applicable) in writing. For the avoidance of doubt, and notwithstanding any direction by the University to modify the location or configuration of the Utility System ~~pursuant to Section 13.4(a)(ii), the~~ as part of the University’s Approval of the Casualty Cost

Estimate, no cost incurred in connection with a Restoration Shortfall Amount shall ~~not~~ be considered a New Approved Capital Improvement Cost.

(b) ~~Rights of University. If (i)~~ If (i) the Concessionaire shall fail to provide the Casualty Cost Estimate in the required timeframe and such failure is not due to a cause outside of Concessionaire's control, (ii) the Concessionaire shall fail or neglect to commence the diligent Restoration of the Utility System or the portion thereof so damaged or destroyed, (iii) having so commenced such Restoration, the Concessionaire shall fail to diligently complete the same in accordance with the terms of this Agreement, or (iii)-iv) this Agreement expires or is terminated in accordance with the terms of this Agreement prior to the completion of any such Restoration by the Concessionaire, ~~this Agreement shall expire or be terminated in accordance with the terms of this Agreement,~~ the University may, but shall not be required to, complete such Restoration at the Concessionaire's expense (to the extent the Concessionaire would otherwise be responsible therefor) and shall be entitled to be paid out of the Restoration Funds, but such payment shall not limit the Concessionaire's obligation to pay the University's reasonable Restoration expenses, less amounts received by the University from such Restoration Funds. In any case where this Agreement shall expire or be terminated prior to the completion of the Restoration, the Concessionaire shall (x) account to the University for all amounts spent in connection with any Restoration which was undertaken, (y) pay over or cause the Depository to pay over to the University within 30 Days after demand therefor, the remainder, if any, of the Restoration Funds received by the Concessionaire prior to such termination or cancellation, and (z) pay over or cause the Depository to pay over to the University, for allocation to the University, within 30 Days after receipt thereof, any Restoration Funds received by the Concessionaire or the Depository subsequent to such termination or cancellation. The Concessionaire's obligations under this Section 13.4(bc) shall survive the expiration or termination of this Agreement.

(ed) Payment of Restoration Funds to Concessionaire (Other than State Risk). Subject to the satisfaction by the Concessionaire of all of the terms and conditions of this Section 13.4, the Depository (in the case of a Concessionaire Retained Casualty or deposit of Restoration Funds up to the Maximum Retained Risk Payment, if applicable) or the University (in the case of a University Retained Casualty less any Maximum Retained Risk Payment, if applicable) shall pay to the Concessionaire ~~from time to time~~ within thirty (30) Days of receipt of Concessionaire's invoice, any Restoration Funds, but, in the case of a Concessionaire Retained Casualty, not more than the amount actually collected by the Depository upon the loss or, in the case of a University Retained Casualty, the amount set forth in the Casualty Cost Estimate plus any Maximum Retained Risk Payment actually collected by the Depository (unless an overage is approved by the University), together with any interest earned thereon, after reimbursing itself therefrom, as well as the University, to the extent, if any, of the reasonable expenses paid or incurred by the Depository and the University in

the collection of such monies, to be utilized by the Concessionaire solely for the Restoration, such payments to be made as follows:

- ~~(i) prior to commencing any Restoration, the Concessionaire shall furnish the University with an estimate of the cost of such Restoration, prepared by an architect or engineer;~~
- ~~(ii)~~ (ii) the Restoration Funds shall be paid to the Concessionaire in installments as the Restoration progresses, subject to Section 13.4(ed)(iii), based upon requisitions to be submitted by the Concessionaire to the Depository (if applicable) and the University in compliance with Section 13.4(e), showing the cost of labor and materials purchased for incorporation in the Restoration, or incorporated therein since the previous requisition, and due and payable or paid by the Concessionaire; provided, however, that if any lien (other than a Permitted Concessionaire Encumbrance) is filed against the Utility System or any part thereof in connection with the Restoration, the Concessionaire shall not be entitled to receive any further installment until such lien is satisfied or discharged (by bonding or otherwise); provided further that notwithstanding the foregoing, but subject to the provisions of Section 13.4(ed)(iii), the existence of any such lien shall not preclude the Concessionaire from receiving any installment of Restoration Funds so long as such lien will be discharged with funds from such installment and at the time the Concessionaire receives such installment the Concessionaire delivers to the University and the Depository (if applicable) a release of such lien executed by the lienholder or and in recordable form;
- ~~(iii)~~ (iii) the amount of any installment to be paid to the Concessionaire shall be the amount of Restoration Funds incurred by the Concessionaire in connection therewith, less 10% of such amount as a retainage (which 10% retainage shall be (i) ~~be~~ reserved without duplication of any retainage reserved by the Concessionaire under its contracts for the Restoration work and (ii) ~~shall be~~ released to the Concessionaire upon completion of the Restoration work), except that such retainage shall not include any amounts for architects' or engineers' fees or permitting or other governmental fees in connection with the Restoration or with respect to each Contractor upon the final completion of each such Contractor's respective work, provided that the unapplied portion of the funds held by the Depository or the University, as applicable, to be used for the Restoration are sufficient to complete the Restoration; provided, however, that all disbursements to the Concessionaire shall be made based upon an architect's or engineer's certificate for payment in accordance with industry standards, and disbursements may be made for advance deposits for materials and Contractors to the extent that such disbursements are customary in the industry and provided that the unapplied portion of the

funds held by the Depository or the University, as applicable, to be used for the Restoration are sufficient to complete the Restoration; and

- (iviii) except as provided in Section 13.4(bc), upon completion of and payment for the Restoration by the Concessionaire, the Depository or University, as applicable, shall pay the balance of the Restoration Funds, if any, to the Concessionaire; provided, however, that if, in the case of a Concessionaire Retained Casualty the insurance proceeds are insufficient to pay for the Restoration (or if there shall be no insurance proceeds) or in the case of a State Risk Retained Casualty or University Retained Casualty, the proceeds available from the University or State Risk pursuant to the preceding paragraphs are less than the final Casualty Cost, the Concessionaire shall nevertheless be required to ~~make complete~~ the Restoration, provided the deficiency in funds necessary to complete the Restoration ~~is provided in accordance with~~ shall be provided by the Concessionaire, except to the extent of the University's responsibility under Section 13.4(ab)(iii)(B).

For the avoidance of doubt, the costs incurred for Capital Improvements made as part of the Restoration shall not be considered Capital Improvement Costs for purposes of Schedule 5 or otherwise included in the calculation of the Utility Fee unless Approved by the University.

- (de) *Conditions of Payment.* The following shall be conditions precedent to each payment made to the Concessionaire as provided in Section 13.4(ed):
- (i) at the time of making such payment, no Concessionaire Default exists, except if such Concessionaire Default is the result of the damage or destruction for which such payment is being made; and
 - (ii) the Restoration shall be carried out under the supervision of the architect or engineer, and there shall be submitted to the Depository (if applicable) and the University the certificate of the architect or engineer (or other evidence reasonably satisfactory to the University) stating that (A) the materials and other items which are the subject of the requisition have been delivered to the Utility System ~~(except with respect to requisitions for advance deposits permitted under Section 13.4(c)(iii)),~~ free and clear of all Encumbrances, and no unsatisfied or unbonded mechanic's liens or other Encumbrances have been claimed, except for any mechanic's lien for claims that will be discharged, by bonding or otherwise, with funds to be received pursuant to such requisition (provided that a release of such lien is delivered to the Depository in accordance with Section 13.4(ed)(ii)), or insured over by title insurance reasonably acceptable to the University, (B) the sum then requested to be withdrawn either has been paid by the Concessionaire or is due and payable to Contractors, engineers, architects or other Persons (whose names and addresses shall be stated), who have rendered or furnished services or materials for the

work and giving a brief description of such services and materials and the principal subdivisions or categories thereof and the several amounts so paid or due to each of such Persons in respect thereof, and stating in reasonable detail the progress of the work up to the date of such certificate, (C) no part of such expenditures has been made the basis, in any previous requisition (whether paid or pending), for the withdrawal of Restoration Funds or has been made out of the Restoration Funds received by the Concessionaire, (D) the sum then requested does not exceed the value of the services and materials described in the certificate, (E) the work relating to such requisition has been performed in accordance with this Agreement, (F) the balance of the Restoration Funds held by the Depository or by the University, as applicable, to be used for the Restoration will be sufficient upon completion of the Restoration to pay for the same in full, and stating in reasonable detail an estimate of the cost of such completion, and (G) in the case of the final payment to the Concessionaire, the Restoration has been completed in accordance with this Agreement.

- (ef) *Payment and Performance Bonds.* If the Concessionaire obtains payment or performance bonds related to a Restoration (which the Concessionaire may or may not obtain in its discretion), the Concessionaire shall name the State of Idaho, the University, their agents, officials, and employees, the Concessionaire and the Leasehold Mortgagee, as their interests may appear as additional obligees, and shall deliver copies of any such bonds to the University promptly upon obtaining them. The claims of any such additional obligee with respect to such payment of performance bonds shall rank pari passu in priority with the claims of all other additional obligees.
- (fg) *Benefit of University.* The requirements of this Section 13.4 are for the benefit only of the University, and no Contractor or other Person shall have or acquire any claim against the University as a result of any failure of the University actually to undertake or complete any Restoration as provided in this Section 13.4 or to obtain the evidence, certifications and other documentation provided for herein.
- (gh) *Investment of Restoration Funds.* Restoration Funds deposited with a Depository shall be invested and reinvested in Eligible Investments at the direction of the Concessionaire, and all interest earned on such investments shall be added to the Restoration Funds.
- (hi) *Lien of Leasehold Mortgage.* Any Restoration Funds not used for the Restoration shall be subject to the lien of the applicable Leasehold Mortgage, but only after such Restoration is complete.

- (j) *Personal Property.* The Concessionaire shall be responsible for all loss or damage to personal property (including materials, fixtures/contents, equipment, tools and supplies) of the Concessionaire unless caused by the University.
- (k) *Effectiveness.* Notwithstanding the date of execution of this Agreement, the Parties agree that, to the extent any casualty occurs from and after the date of the execution of this Agreement, this Section 13.4 shall apply with respect to the costs and restoration thereof, provided that, prior to the date of execution of this Agreement and with respect to any Uninsured Utility System Property, the Concessionaire shall be liable for the full Restoration costs associated with any casualty affecting such Uninsured Utility System Property that occurred prior to the date of execution of this Agreement and shall continue to be liable for such costs after the date of execution of this Agreement until the Concessionaire pays to the University the University Retained Risk Annual Payment (or a prorated amount, if applicable).

Section 13.5. Additional University Requirements.

- (a) The Concessionaire shall submit, at the Concessionaire's cost and expense, all design documents for proposed Capital Improvements to the Utility System to the standard University design and construction review process, including, but not limited to submitting documents to the University of Idaho Facilities Department, c/o the Director of Architecture and Engineering Services and the University's property insurance carrier for a plan review.
- (b) The Concessionaire shall cooperate and participate, at the Concessionaire's cost and expense, in any and all Utility System Land visits or site inspections by or for any University insurance carrier.

ARTICLE 14 ADVERSE ACTIONS

Section 14.1. Adverse Action.

- (a) An "Adverse Action" shall occur if the City of Moscow, Idaho, the County of Latah, Idaho, the State of Idaho, or any agency, political division or unit or commission thereof, or the University, at any time during the Term, takes any action or actions and the effect of such action or actions, individually or in the aggregate, is reasonably expected (i) to be principally borne by the Concessionaire or by private sector utility concessionaires at universities and other public institutions in Idaho, including the Concessionaire, and, in either case, not by other Persons and (ii) to have a material adverse effect on the fair market value of the Concessionaire Interest (whether as a result of a decrease in the Utility Fee or other revenues, increased expenses that cannot be recovered pursuant to this Agreement, or both), except where such action is in response to any act or omission on the part of the Concessionaire that is illegal (other than an act or omission rendered illegal by virtue of the Adverse Action) or such action

is otherwise permitted under this Agreement; provided, however, that none of the following shall be an Adverse Action: (A) the development, redevelopment, construction, modification or change in the operation of any existing or new utility facility (other than any Utility Facility) or utility (including a new source of energy or power) (other than the Utilities) whether or not it results in the reduction of the Variable Fee Component over time, (B) the imposition of a state or local Tax of general application or federal Tax or an increase in state or local Taxes of general application or federal Taxes, and (C) any action of the Idaho Public Utilities Commission or the Federal Energy Regulatory Commission, or their respective successors, that subjects the Concessionaire to such agency's regulatory jurisdiction due solely to the Utility System Operations performed in accordance with this Agreement.

- (b) If an Adverse Action occurs, the Concessionaire may elect, subject to Section 14.2 and Section 14.3, to either (i) be paid by the University the Concession Compensation with respect thereto (such Concession Compensation, the "AA-Compensation") or (ii) terminate this Agreement and be paid by the University the Termination Damages, in either case by giving notice in the manner described in Section 14.1(c).
- (c) If an Adverse Action occurs, the Concessionaire shall give written notice (the "AA-Preliminary Notice") to the University within 30 Days following the date on which the Concessionaire first became aware of the Adverse Action stating that an Adverse Action has occurred. Within 180 Days following the date of delivery of the AA-Preliminary Notice, the Concessionaire shall give the University another notice (the "AA-Notice") setting forth (i) the details of the effect of the occurrence that is principally borne by the Concessionaire, (ii) details of the material adverse effect of the said occurrence on the fair market value of the Concessionaire Interest, (iii) a statement as to which right in Section 14.1(b) the Concessionaire elects to exercise, and (iv) if the Concessionaire elects to exercise the right to AA-Compensation under Section 14.1(b), the amount claimed as AA-Compensation and details of the calculation thereof. The University shall, after receipt of the AA-Notice, be entitled by notice delivered to the Concessionaire no later than 30 Days following the date of receipt of the AA-Notice, to require the Concessionaire to provide such further supporting particulars as the University may reasonably consider necessary. If the University wishes to dispute the occurrence of an Adverse Action or the amount of AA-Compensation, if any, claimed in the AA-Notice, the University shall give written notice of dispute (the "AA-Dispute Notice") to the Concessionaire within 30 Days following the date of receipt of the AA-Notice stating in reasonable detail the grounds for such dispute. If neither the AA-Notice nor the AA-Dispute Notice has been withdrawn within 30 Days following the date of receipt of the AA-Dispute Notice by the Concessionaire, the matter shall be submitted to the dispute resolution procedure in Article 18.

- (d) If the Concessionaire has elected to exercise its right to AA-Compensation pursuant to Section 14.1(b), the University shall pay such AA-Compensation as Concession Compensation in accordance with Article 15.
- (e) Payment of the entire sum of the Termination Damages or the AA-Compensation, as the case may be, by the University to the Concessionaire, shall constitute full and final satisfaction of all amounts that may be claimed by the Concessionaire for and in respect of the occurrence of an Adverse Action, as the case may be, and, upon such payment, the University shall be released and forever discharged by the Concessionaire from any and all liability in respect of such Adverse Action, except if the Concessionaire elects to be paid AA-Compensation and the effect of the applicable Adverse Action continues to be borne after the Compensation Calculation Measuring Period in which it took place, in which case, the Concessionaire may make a claim for AA-Compensation in subsequent Compensation Calculation Measuring Periods to the extent the Concessionaire is affected by such Adverse Action in such Compensation Calculation Measuring Period, but the Concessionaire may not change its election to receive AA-Compensation with respect to such Adverse Action.

Section 14.2. Termination.

- (a) If the Concessionaire has elected to exercise its right to terminate this Agreement in connection with an Adverse Action pursuant to Section 14.1(b), then this Agreement, subject to Section 14.3, shall terminate 60 Days following the date of receipt of the AA-Notice by the University, and the University shall pay an amount equal to the aggregate of (i) the Utility System Concession Value as of the date of such termination (which shall be determined as if no Adverse Action has occurred), *plus* (ii) without duplication, the out-of-pocket and documented costs and expenses incurred by the Concessionaire (which costs and expenses shall include reasonable payments due and payable by the Concessionaire to the Operator or other Contractors pursuant to an Operating Agreement or similar agreement) or the Operator as a result of such termination, *plus* (iii) the Concession Compensation calculated for the period between the date of the Adverse Action and the date of termination, *less* (iv) any insurance or condemnation proceeds received by the Concessionaire in respect of all or any portion of the Utility System as a result of such Adverse Action (collectively, the "Termination Damages"), together with any Taxes payable by the Concessionaire on such Termination Damages that exceed the Taxes the Concessionaire would have paid on future receipts of the Utility Fee if the Termination had not occurred (using the Tax rates in effect when the Termination Damages would be payable) and using the same assumptions for the calculation of the amount of such future receipts as are used in the calculation of Termination Damages, to the Concessionaire on the Reversion Date or, if the Termination Damages are determined on a date subsequent to the Reversion Date, then not later than 60 Days following the date of determination of the Termination Damages; provided that, subject to the right of the Concessionaire

to receive interest at the Bank Rate on the payment owed by the University from the date of receipt of the AA-Dispute Notice to the date on which payment is made, the University may defer any such payment for an additional 120 Days in the University's discretion; provided, however, that any amounts received by the Concessionaire or any Leasehold Mortgagee from any insurance policies payable as a result of damage or destruction to the Utility System that has not been remedied prior to the Reversion Date, shall, to the extent not used to remedy such effects, be deducted from the amount payable by the University to the Concessionaire, so long as the University has not received any such amounts pursuant to Section 13.4.

- (b) Any dispute arising out of the determination of the Termination Damages shall be submitted to the dispute resolution procedure in Article 18.
- (c) This Agreement shall not terminate pursuant to Section 14.2(a) unless the Concessionaire has first obtained and delivered to the University the written consent of the Leasehold Mortgagee to such termination.

Section 14.3. Right of the University to Remedy. If the University wishes to remedy the occurrence of an Adverse Action (other than an Adverse Action by the University that constitutes a breach of this Agreement, to which this Section 14.3 shall have no application without the written consent of the Concessionaire), including by reimbursing the Concessionaire such funds as are necessary to compensate the Concessionaire for the material adverse economic effect on the Concessionaire of such Adverse Action, the University shall give written notice thereof to the Concessionaire within 30 Days following the date of receipt of the AA-Notice. If the University gives such notice it must remedy the applicable Adverse Action within 120 Days following the date of receipt of the AA-Notice or, if a AA-Dispute Notice has been given, within 120 Days following the final determination pursuant to Article 18 that an Adverse Action occurred; provided, however, that in the event of a remedy involving payment of funds to the Concessionaire, the University shall be deemed to have remedied the applicable Adverse Action as of the date that the University provides a written commitment to the Concessionaire to pay such funds from time to time as are necessary to compensate the Concessionaire as it is financially adversely affected by the applicable Adverse Action from time to time. If the University elects to remedy the occurrence of an Adverse Action within the applicable period of time, the right of the Concessionaire shall be limited to a claim for AA-Compensation with respect to such Adverse Action.

Section 14.4. Other Actions by Governmental Authorities. In the event that any Governmental Authority proposes to take any action at any time during the Term (including enacting any Law) and the effect of such action is reasonably expected (i) to be principally borne by the Concessionaire or by private sector utility concessionaires at universities and other public institutions in Idaho, including the Concessionaire (and not by others) and (ii) to have a Material Adverse Effect, except where such action is in response to any act or omission on the part of the Concessionaire that is illegal (other than an act or omission rendered illegal by virtue of an Adverse Action or such action by any such Governmental Authority), then at the request of the Concessionaire, the University shall use its reasonable efforts to oppose and challenge such action by any such Governmental Authority; provided, however, that all reasonable

out-of-pocket costs and expenses incurred by the University in connection with such opposition or challenge shall be borne by the Concessionaire.

Section 14.5. Regulatory Filings. The Parties acknowledge and agree that they share a common interest in any regulatory proceedings that involve the Utility System Operations. Consistent therewith, the Parties agree that, to the extent that the Concessionaire or the University is required to make any regulatory filing or submission with respect to a tariff or rate for the Utility System or the Utility Fee, the Concessionaire and the University shall reasonably cooperate in connection with such required filing or submission and shall, collectively, only make one filing or submission with the applicable regulatory agency. Such cooperation shall include appearing at, and participating in, any regulatory proceeding at the request of the other Party. The Concessionaire and the University shall also reasonably cooperate with respect to any required regulatory filings or submissions not involving a tariff or rate for the Utility System or the Utility Fee, to the extent practicable.

ARTICLE 15

DELAY EVENTS; CONCESSION COMPENSATION AND KPI COMPENSATION

Section 15.1. Delay Events.

- (a) If the Concessionaire is affected by a Delay Event, it shall give written notice as soon as practicable but in no event later than 10 Business Days following the date on which it first became aware of the effect of such Delay Event on the Concessionaire (provided that in the case of such Delay Event being a continuing cause of delay, only one notice shall be necessary), which notice shall include (i) a statement of which Delay Event the claim is based upon, (ii) details of the circumstances from which the delay arises, and (iii) an estimate of the delay in the performance of obligations under this Agreement attributable to such Delay Event and information in support thereof, if known at that time. The University shall, after receipt of any such notice, be entitled by notice to require the Concessionaire to provide such further supporting particulars as the University may reasonably consider necessary.
- (b) The Concessionaire shall notify the University within 5 Business Days following the date on which it first became aware that a Delay Event has ceased.
- (c) Subject to the Concessionaire giving the notice required in Section 15.1(a), a Delay Event shall excuse the Concessionaire from whatever performance is prevented by the Delay Event referred to in such notice and, to the extent applicable, for such appropriate number of Days as the University and the Concessionaire jointly determine, each acting reasonably. If the University and the Concessionaire cannot agree upon the period of extension, then either Party shall be entitled to refer the matter to the dispute resolution procedure in Article 18. This Section 15.1(c) shall not excuse the Concessionaire from the performance and observance under this Agreement of all obligations and covenants not affected by the Delay Event. While a Delay Event is occurring, the Utility Fee shall be reduced by an amount equal to the Utility Fee multiplied

by the percentage of the Utility System that is inoperable as a result of the Delay Event, as determined by the University in its reasonable discretion (as determined by the reduction in delivery capacity as compared to the delivery capacity immediately preceding such Delay Event), provided that such Delay Event shall be deemed a Compensation Event. Notwithstanding the occurrence of a Delay Event, the Concessionaire shall continue its performance and observance under this Agreement of all of its obligations and covenants to the extent that it is reasonably able to do so and shall use its reasonable efforts to minimize the effect and duration of the Delay Event. Nothing herein shall permit or excuse noncompliance with a change to applicable Laws.

- (d) Except as provided in the immediately following sentence, (i) if a Delay Event occurs that has the effect of causing physical damage or destruction to a material part of the Utility System that results in the Utility System being substantially unavailable for the provision of Utility Services and such effect continues for a period in excess of 120 continuous Days or 120 non-continuous Days within a 360-Day period and has a Material Adverse Effect, for which the Concessionaire is not made whole through Concession Compensation, or (ii) if insurance policies payable (or that should have been payable but for the breach of an obligation to take out and maintain such insurance policy by the Concessionaire), condemnation or other similar proceeds are insufficient to restore the Concessionaire to the same economic position as it would have been in the absence of such event and the Concessionaire is not otherwise made whole through Concession Compensation, then, notwithstanding Section 2.1, in either case, the Concessionaire shall have the right, but not the obligation, by written notice to the University within 30 Days after the Delay Event Remedy is permitted to be elected, to extend the Term for a period that would be sufficient to compensate the Concessionaire and restore it to the same economic position as it would have been in had such Delay Event not occurred (a “Delay Event Remedy”); provided, however, in no event shall the Term be extended if such extension is prohibited by Law or if the extended Term, when taking into account such extension, would subject the Concessionaire or the University to a leasehold tax, conveyance fee or similar charge under applicable Law. If the Concessionaire elects to exercise the right to the Delay Event Remedy but such exercise is prohibited by Law or would subject the Concessionaire or the University to a leasehold tax, conveyance fee or similar charge under applicable Law, (i) the Delay Event Remedy shall be modified such that the Term is extended only for such period as would not cause exercise of the Delay Event Remedy to be prohibited by Law or to subject the Concessionaire or the University to a leasehold tax, conveyance fee or similar charge under applicable Law, and (ii) the relevant Delay Event shall be a Compensation Event to the extent necessary to compensate the Concessionaire and restore it to the same economic position as it would have been in, absent the modification to the Delay Event Remedy pursuant to clause (i) of this sentence.
- (e) If the Concessionaire elects to exercise the right to the Delay Event Remedy, within 5 Business Days following the date on which the Concessionaire first

became aware of its right to the Delay Event Remedy pursuant to Section 15.1(d)(i) or Section 15.1(d)(ii), the Concessionaire shall give written notice (a “Delay Event Remedy Notice”) to the University setting forth (i) the details of the relevant Delay Event and its effect on either causing physical damage or destruction to the Utility System that results in the Utility System being substantially unavailable for the provision of Utility Services, (ii) the amount claimed to be required to restore the Concessionaire to the same economic position as it would have been in had such Delay Event not occurred (including the details of the calculation thereof), and (iii) the details of the relationship between such amount and the Concessionaire’s proposed extension of the Term. The University shall, after receipt of the Delay Event Remedy Notice, be entitled by notice to require the Concessionaire to provide such further supporting particulars as the University may reasonably consider necessary. If the University wishes to dispute the occurrence of a Delay Event or the Delay Event Remedy claimed in the Delay Event Remedy Notice, the University shall give written notice to dispute (the “Delay Event Remedy Dispute Notice”) to the Concessionaire within 30 Days following the date of receipt of the Delay Event Remedy Notice stating the grounds for such dispute, and if neither the Delay Event Remedy Notice nor the Delay Event Remedy Dispute Notice has been withdrawn within 30 Days following the date of receipt of the Delay Event Remedy Dispute Notice by the Concessionaire, the matter shall be submitted to the dispute resolution procedure in Article 18. For the avoidance of doubt, if the conditions set forth in Section 15.1(d)(i) and Section 15.1(d)(ii) occur with respect to the same Delay Event, the Concessionaire may have 2 opportunities to provide a Delay Event Remedy Notice.

Section 15.2. Notice of Compensation Events and KPI Events. Except as provided elsewhere in this Agreement, if a Compensation Event occurs, the Concessionaire shall give written notice to the University within 45 Days following the date on which the Concessionaire first became aware of the Compensation Event stating that a Compensation Event has occurred. Except as provided elsewhere in this Agreement, if a KPI Event occurs, the University shall give written notice to the Concessionaire within 45 Days following the date on which the University first became aware of the KPI Event stating that a KPI Event has occurred.

Section 15.3. Payments of Concession Compensation and KPI Compensation.

- (a) Within 30 Days after each Compensation Calculation Date, the Concessionaire shall send the University notice setting forth all Concession Compensation due for the immediately preceding Compensation Calculation Measuring Period, and the University shall send the Concessionaire notice setting forth all KPI Compensation due for the immediately preceding Compensation Calculation Measuring Period. Each such notice shall set forth: (i) the amount claimed and details of the calculation thereof; (ii) details of the Compensation Event(s), Adverse Action(s) and KPI Event(s), as applicable, as a result of which Concession Compensation and KPI Compensation, as applicable, is claimed therein, including an explanation of the reasons that such event(s) constitute Compensation Event(s), Adverse Action(s) and KPI Event(s), as applicable,

under the terms of this Agreement; and (iii) the amount claimed as Concession Compensation and KPI Compensation, as applicable, with respect to each such Compensation Event, Adverse Action and KPI Event, as applicable, and details of the calculation thereof.

- (b) If either Party wishes to dispute the occurrence of any Compensation Event(s), Adverse Action(s) or KPI Event(s) set forth in the notices described in Section 15.3(a) or the amounts claimed thereunder, then such Party shall give written notice of dispute (the “Dispute Notice”) to the other Party within 30 Days following the date of receipt of the relevant notice stating the grounds for such dispute. If the Dispute Notice has not been withdrawn or the dispute otherwise resolved by the Parties within 30 Days following the date of receipt of the Dispute Notice, the matter shall be submitted to the dispute resolution procedure set forth in Article 18.
- (c) The University and the Concessionaire shall cooperate and assist in good faith in the determination of the Concession Compensation and KPI Compensation in accordance with this Section 15.3, including making available, to the extent reasonably necessary, books, records, work papers and personnel at such reasonable times as any Party shall request and permitting (at the expense of the requesting Party) the copying of any records or extracts thereof reasonably requested, subject to Section 3.12.
- (d) The University shall have the right, prior to any payment of the Concession and KPI Compensation Balance, to include any Concession Compensation in the applicable Utility Fee as (i) a New Approved Capital Improvement if the Concession Compensation was incurred in connection with the construction of a Capital Improvement or (ii) an Uncapped O&M Cost payable over the next Fiscal Year in equal monthly installments.
- (e) Following the final determination of the Concession Compensation and KPI Compensation, (i) if the Concession and KPI Compensation Balance is positive, then the University shall pay, within 90 Days of such final determination, to the Concessionaire, the Concession and KPI Compensation Balance or add such amount to the immediately succeeding payment of the Utility Fee in accordance with Section 15.3(d), if applicable or (ii) if the Concession and KPI Compensation Balance is negative, then the Concessionaire shall pay, within 90 Days of such final determination, to the University, the absolute amount of the Concession and KPI Compensation Balance or, with the University’s consent, offset such amount against the immediately succeeding payment of the Utility Fee, if applicable.
- (f) For the determination of the Concession and KPI Compensation Balance for the Compensation Calculation Date that is the End Date, the Concession Compensation shall also include all Unrecovered Balances as of the End Date, unless this Agreement is terminated as a result of a Concessionaire Default, in

which case no Unrecovered Balances shall be included in the Concession and KPI Compensation Balance.

Section 15.4. KPI Compensation. Other than the University's right to cause the Concessionaire to remove the Operator pursuant to Section 3.3(c), the payment of KPI Compensation by the Concessionaire shall constitute the Concessionaire's sole and exclusive liability and the University's sole and exclusive remedy for any KPI Event.

Section 15.5. Maximum Annual Amount of KPI Compensation. Notwithstanding anything to the contrary contained herein, the maximum amount of KPI Compensation for which the Concessionaire may be liable in any given Fiscal Year shall be the greater of (a) \$3,178,326.84 and (b) 30% of the Utility Fee for that Fiscal Year; provided, any KPI Compensation in excess of such cap in any Fiscal Year for which the Concessionaire would otherwise be liable shall become due and owing in the subsequent Fiscal Year (but subject to the same cap in such Fiscal Year) until all such outstanding amounts are paid to the University and such deferred amounts shall accrue interest at a rate equal to the lesser of 20% per annum and the maximum interest rate permitted by Law. For the avoidance of doubt, the limitation on the maximum amount of KPI Compensation shall not limit the number of KPI Events that have occurred, including the determination of the number of KPI Events in a Fiscal Year for purposes of Section 3.3 or the determination of future KPI Compensation.

ARTICLE 16 DEFAULTS

Section 16.1. Default by the Concessionaire.

- (a) *Events of Default.* The occurrence of any one or more of the following events during the Term shall constitute a "Concessionaire Default" under this Agreement:
- (i) if the Concessionaire fails to comply with, perform or observe any material obligation, covenant, agreement, term or condition in this Agreement other than a breach of the Performance Standards or a KPI Event, and such failure continues unremedied for a period of 90 Days following notice thereof (giving particulars of the failure in reasonable detail) from the University to the Concessionaire or for such longer period as may be reasonably necessary to cure such failure, provided, in the latter case, that the Concessionaire has demonstrated to the satisfaction of the University, that (A) it is proceeding, and will proceed, with all due diligence to cure or cause to be cured such failure, (B) its actions can be reasonably expected to cure or cause to be cured such failure within a reasonable period of time acceptable to the University, and (C) such failure is, in fact, cured within such period of time;
 - (ii) if the Concessionaire fails to remedy any Transfer of this Agreement or all or any portion of the Concessionaire Interest in contravention of Article

17 within 10 Business Days following notice thereof from the University to the Concessionaire;

- (iii) if the Concessionaire fails to comply with the requirements or directives of a final award in a matter submitted to dispute resolution in accordance with Article 18, and such failure continues unremedied for a period of 30 Days following notice thereof from the University to the Concessionaire, or for such longer period as may be reasonably necessary to cure such failure, provided, in the latter case, that the Concessionaire has demonstrated to the satisfaction of the University, that (A) it is proceeding, and will proceed, with all due diligence to cure or cause to be cured such failure, (B) its actions can be reasonably expected to cure or cause to be cured such failure within a reasonable period of time acceptable to the University, and (C) such failure is, in fact, cured within such period of time;
- (iv) if the Concessionaire (A) admits, in writing, that it is unable to pay its debts as such become due, (B) makes an assignment for the benefit of creditors, (C) files a voluntary petition under Title 11 of the United States Code, or if such petition is filed against it and an order for relief is entered, or if the Concessionaire files any petition or answer seeking, consenting to or acquiescing in any reorganization, arrangement, composition, readjustment, liquidation, dissolution or similar relief under the present or any future United States Bankruptcy Code or any other present or future applicable Law, or shall seek or consent to or acquiesce in or suffer the appointment of any trustee, receiver, custodian, assignee, sequestrator, liquidator or other similar official of the Concessionaire or of all or any substantial part of its properties or of the Utility System or any interest therein, or (D) takes any corporate action in furtherance of any action described in this Section 16.1(a)(iv);
- (v) if within 90 Days after the commencement of any proceeding against the Concessionaire seeking any reorganization, arrangement, composition, readjustment, liquidation, dissolution or similar relief under the present or any future United States Bankruptcy Code or any other present or future applicable Law, such proceeding has not been dismissed, or if, within 90 Days after the appointment, without the consent or acquiescence of the Concessionaire, of any trustee, receiver, custodian, assignee, sequestrator, liquidator or other similar official of the Concessionaire or of all or any substantial part of its properties or of the Utility System or any interest therein, such appointment has not been vacated or stayed on appeal or otherwise, or if, within 90 Days after the expiration of any such stay, such appointment has not been vacated;
- (vi) if a levy under execution or attachment has been made against all or any part of the Utility System or any interest therein as a result of any Encumbrance (other than a Permitted Concessionaire Encumbrance)

created, incurred, assumed or suffered to exist by the Concessionaire or any Person claiming through it, and such execution or attachment has not been vacated, removed or stayed by court order, bonding or otherwise within 60 Days after the Concessionaire becomes aware of such levy, unless such levy resulted from actions or omissions of the University or its Representatives; or

- (vii) the Concessionaire repudiates in writing any of its material obligations under this Agreement.

Notwithstanding the foregoing, a Concessionaire Default shall not include any failure by the Concessionaire to perform its obligations under this Agreement (other than payment obligations) to the extent such failure is the result of Force Majeure.

- (b) *Remedies of the University upon Concessionaire Default.* Upon the occurrence, and during the continuance, of a Concessionaire Default, the University may, by notice to the Concessionaire, declare the Concessionaire to be in default and may, subject to the provisions of Article 18 and Article 19, do any or all of the following as the University, in its discretion, shall determine:

- (i) subject to the cure rights of the Leasehold Mortgagee set forth in Section 19.3, the University may terminate this Agreement by giving 30 Days' prior notice to the Concessionaire upon the occurrence of any Concessionaire Default; provided, however, that the Concessionaire shall be entitled to cure a Concessionaire Default pursuant to Section 16.1(a)(i) by (i) agreeing within such 30-Day period to pay any Losses sustained as a result of such Concessionaire Default and (ii) providing the University with a written work plan within such 30-Day period outlining the actions by which the Concessionaire will ensure future compliance with either (x) the obligation, covenant, agreement, term or condition in this Agreement or (y) the requirements or directives of the issued final award in accordance with Article 18 that the Concessionaire failed to perform or observe, which work plan is Approved by the University, but any failure of the Concessionaire to comply in any material respect with such Approved work plan (other than as a result of a Delay Event) following 30 Days' notice of such failure from the University to the Concessionaire shall be deemed to be a Concessionaire Default described in Section 16.1(a)(i) and the entitlement of the Concessionaire to cure such Concessionaire Default by the delivery of an Approved work plan shall not apply thereto;
- (ii) if the Concessionaire Default is by reason of the failure to pay any monies to another Person, the University may (without obligation to do so) make payment on behalf of the Concessionaire of such monies unless such non-payment is due to a bona fide dispute, and any amount so paid by the

University shall be payable by the Concessionaire to the University within 3 Business Days after demand therefor;

- (iii) subject to the cure rights of the Leasehold Mortgagee set forth in Section 19.3, the University may cure the Concessionaire Default (but this shall not obligate the University to cure or attempt to cure a Concessionaire Default or, after having commenced to cure or attempted to cure a Concessionaire Default, to continue to do so), and all costs and expenses reasonably incurred by the University in curing or attempting to cure the Concessionaire Default, shall be payable by the Concessionaire to the University within 3 Business Days after written demand therefor; provided, however, that (A) the University shall not incur any liability to the Concessionaire for any act or omission of the University or any other Person in the course of remedying or attempting to remedy any Concessionaire Default unless resulting from the University's recklessness, gross negligence or willful misconduct; (B) the University's cure of any Concessionaire Default shall not affect the University's rights against the Concessionaire by reason of the Concessionaire Default; and (C) the University may seek specific performance, injunction or other equitable remedies, it being acknowledged that damages are an inadequate remedy for a Concessionaire Default;
- (iv) the University may seek to recover its Losses arising from such Concessionaire Default and any amounts due and payable under this Agreement and, in connection therewith, exercise any recourse available to any Person who is owed damages or a debt;
- (v) with respect to those Concessionaire Defaults that entitle the University to terminate this Agreement pursuant to Section 16.1(b)(i), the University may terminate the Concessionaire's right to use, operate, maintain, possess, control and rehabilitate the Utility System and the Concessionaire's right to collect from the University and retain the Utility Fee, and in such event, the University or the University's agents and servants may immediately or at any time thereafter take possession and control of the Utility System, by any available action under Law or proceeding at law or in equity, and with or without terminating this Agreement, and undertake any and all of the Utility System Operations; provided, however, that no such action by the University shall be construed as an election on its part to terminate this Agreement unless a notice of such intention is given to the Concessionaire; and
- (vi) the University may exercise any of its other rights and remedies provided for hereunder or at law or equity.

Section 16.2. Default by the University.

- (a) *Events of Default.* The occurrence of any one or more of the following events during the Term shall constitute a “University Default” under this Agreement:
- (i) if the University fails to pay the Utility Fee, the Forecast Utility Fee or the Concession and KPI Compensation Balance to the extent the University is required to do so pursuant to Section 15.3(f), each in accordance herewith and such failure continues unremedied for a period of 5 Business Days following notice thereof (giving particulars of the failure in reasonable detail) from the Concessionaire to the University;
 - (ii) if the University fails to comply with or observe any material obligation, covenant, agreement, term or condition in this Agreement (other than an Adverse Action or the payment of the Utility Fee, the Forecast Utility Fee or the Concession and KPI Compensation Balance to the extent the University is required to do so pursuant to Section 15.3(f)) and such failure continues unremedied for a period of 90 Days following notice thereof (giving particulars of the failure in reasonable detail) from the Concessionaire to the University or for such longer period as may be reasonably necessary to cure such failure, provided, in the latter case, that the University has demonstrated to the satisfaction of the Concessionaire, that (A) it is proceeding with all due diligence to cure or cause to be cured such failure, (B) its actions can be reasonably expected to cure or cause to be cured such failure within a reasonable period of time acceptable to the Concessionaire, and (C) such failure is, in fact, cured within such period of time;
 - (iii) if the University fails to comply with the requirements or directives of a final award in a matter submitted to dispute resolution in accordance with Article 18 and such default continues unremedied for a period of 30 Days following notice thereof from the Concessionaire to the University, or for such longer period as may be reasonably necessary to cure such failure, provided, in the latter case, that the University has demonstrated to the satisfaction of the Concessionaire, acting reasonably, that (A) it is proceeding, and will proceed, with all due diligence to cure or cause to be cured such failure, (B) its actions can be reasonably expected to cure or cause to be cured such failure within a reasonable period of time acceptable to the Concessionaire, acting reasonably and (C) such failure is, in fact, cured within such period of time;
 - (iv) if a levy under execution or attachment has been made against all or any part of the Utility System or the Concessionaire Interest as a result of any Encumbrance (other than a Permitted University Encumbrance) created, incurred, assumed or suffered to exist by the University or any Person claiming through it, and such execution or attachment has not been vacated, removed or stayed by court order, bonding or otherwise within a

period of 60 Days, unless such levy resulted from actions or omissions of the Concessionaire or its Representatives or if all or a material part of the Utility System shall be subject to a condemnation or similar taking by the University or any agency thereof;

- (v) if the University (A) admits, in writing, that it is unable to pay its debts as such become due, (B) makes an assignment for the benefit of creditors, (C) files a voluntary petition under Title 9 of the United States Code, or if such petition is filed against it and an order for relief is entered, or if the University files any petition or answer seeking, consenting to or acquiescing in any reorganization, arrangement, composition, readjustment, liquidation, dissolution or similar relief under the present or any future United States Bankruptcy Code or any other present or future applicable Law, or shall seek or consent to or acquiesce in or suffer the appointment of any trustee, receiver, custodian, assignee, sequestrator, liquidator or other similar official of the University, or of all or any substantial part of its properties (in each case, to the extent applicable to a municipality), or (D) takes any action in furtherance of any action described in this Section 16.2(a)(v); or if within 90 Days after the commencement of any proceeding against the University seeking any reorganization, arrangement, composition, readjustment, liquidation, dissolution or similar relief under the present or any future United States Bankruptcy Code or any other present or future applicable Law, such proceeding has not been dismissed, or if, within 90 Days after the appointment, without the consent or acquiescence of the University, of any trustee, receiver, custodian, assignee, sequestrator, liquidator or other similar official of the University or of all or any substantial part of its properties (in each case, to the extent applicable to a municipality), such appointment has not been vacated or stayed on appeal or otherwise, or if, within 90 Days after the expiration of any such stay, such appointment has not been vacated; or
- (vi) the University repudiates in writing any of its material obligations under this Agreement.

Notwithstanding the foregoing, a University Default shall not include any failure to perform its obligations under this Agreement (other than payment obligations) to the extent such failure is the result of Force Majeure.

- (b) *Remedies of Concessionaire Upon University Default.* Upon the occurrence, and during the continuance, of a University Default, the Concessionaire may by notice to the University declare the University to be in default and may, subject to the provisions of Article 18, do any or all of the following as the Concessionaire, in its discretion, shall determine:
 - (i) terminate this Agreement by giving 60 Days' prior notice to the University; provided, however, that the University shall be entitled to cure

a University Default pursuant to Section 16.2(a)(ii) or Section 16.2(a)(iii) by (i) agreeing within such 60-Day period to pay any Losses sustained as a result of such University Default or (ii) providing the Concessionaire with a written work plan within such 60-Day period outlining the actions by which the University will ensure future compliance with either (x) the obligation, covenant, agreement, term or condition in this Agreement that the University failed to perform or observe or (y) the requirements or directives of the final award issued in accordance with Article 18 that the University failed to perform or observe, which work plan is approved by the Concessionaire, but any failure of the University to comply in any material respect with such approved work plan following 30 Days' notice of such failure from the Concessionaire to the University shall be deemed to be a University Default described in Section 16.2(a)(ii) and the entitlement of the University to cure such University Default by the delivery of an approved work plan shall not apply thereto; and upon such termination, the University shall be obligated to pay to the Concessionaire the Utility System Concession Value plus, without duplication, the unpaid Concession and KPI Compensation Balance (for the avoidance of doubt, including any Unrecovered Balances) and the out-of-pocket and documented costs and expenses incurred by the Concessionaire as a result of such termination together with any Taxes payable by the Concessionaire on the foregoing that exceed the Taxes the Concessionaire would have paid on future receipts of the Utility Fee if the termination of this Agreement pursuant to this Section 16.2(b)(i) had not occurred (using the Tax rates in effect when such damages would be payable) and using the same assumptions for the calculation of the amount of such future receipts as are used in the calculation of Utility System Concession Value;

- (ii) exercise any of its rights or remedies at law or in equity;
- (iii) seek to recover its Losses and any amounts due and payable under this Agreement and, in connection therewith, exercise any recourse available to any Person who is owed damages or a debt; and
- (iv) seek specific performance, injunction or other equitable remedies, it being acknowledged that damages are an inadequate remedy for a University Default.

Section 16.3. Consequences of Termination or Reversion. Upon the termination or expiration of this Agreement, notwithstanding any claims the Parties may have against each other and subject to Section 16.2(b)(iii), the following provisions shall apply:

- (a) the Concessionaire shall, without action whatsoever being necessary on the part of the University (other than any payment obligations of the University with respect to such termination (including, for the avoidance of doubt, any payment obligations pursuant to Sections 14.2(a), 15.3(f) or 16.1(b)(i), if any, and the payment obligation set forth in this Section 16.3(a)), surrender, transfer and

deliver to the University the Utility System (including all improvements to the Utility System), the Utility System Assets (to the extent they have not been disposed of in the ordinary course of business) and all tangible and intangible personal property of the Concessionaire (including inventories) that is included in the Utility System or used in connection with the Utility System Operations, in good order, condition and repair (reasonable wear and tear excepted), determined reasonably in accordance with the then applicable Performance Standards, free and clear of all Encumbrances other than (w) Permitted Concessionaire Encumbrances set forth in clauses (iv) and (vii) of the definition of that term, (x) Permitted University Encumbrances, (y) those created by or suffered to exist or consented to by the University or any Person claiming through it, and (z) with respect to any property added to the Utility System after the Time of Closing, title defects affecting such property in existence on the date such property is added to the Utility System, all in exchange for \$1 paid by the University on the Reversion Date;

- (b) the Concessionaire hereby waives any notice now or hereafter required by Law with respect to transfer of the Utility System on the Reversion Date;
- (c) the University shall, as of the Reversion Date, assume full responsibility for the Utility System Operations, and as of such date, the Concessionaire shall have no liability or responsibility for Utility System Operations occurring after such date;
- (d) the Concessionaire shall be liable for all costs, expenses and other amounts for which it is liable or responsible hereunder incurred up to but not including the Reversion Date, and the University shall be liable for all costs, expenses and amounts incurred in connection with the Utility System Operations on and after the Reversion Date;
- (e) the University shall have the option, subject to the rights of any Leasehold Mortgagee, or its designee or nominee, to enter into a New Agreement with a third party, by providing notice to the Concessionaire requiring that the Concessionaire assign, without warranty or recourse to the Concessionaire, to the fullest extent permitted by Authorizations and applicable Law, all of its right, title and interest in, to and under (in each of the following cases, to the extent assignable) all or any of the Operating Agreements then in effect and all Authorizations to the University or its nominee for the remainder of their respective terms; provided, however, that if the University exercises such option, the right, title and interest of the Concessionaire in, to and under such Operating Agreements and Authorizations shall be assigned to the University or its nominee as of the Reversion Date and the Concessionaire shall surrender the Utility System to the University and shall cause all Persons claiming under or through the Concessionaire to do likewise, and the University shall assume in writing, pursuant to an assumption agreement satisfactory to the Concessionaire, the Concessionaire's obligations under the Operating Agreements that arise in respect of, or relate to, any period of time falling on and after the Reversion Date; provided further, that if the University does not exercise such option, the

Concessionaire shall take such steps as are necessary to terminate the Operating Agreements to the extent permitted thereunder and in accordance with the terms thereof;

- (f) the Concessionaire, at its sole cost and expense, shall promptly deliver to the University copies of all records and other documents relating to the Utility Fee that are in the possession of the Concessionaire or its Representatives and all other then-existing records and information relating to the Utility System as the University, acting reasonably, may request;
- (g) the Concessionaire shall execute and deliver to the University transfer of title documents and other instruments reasonably required by the University to evidence such termination;
- (h) the Concessionaire shall assist the University in such manner as the University may require to ensure the orderly transition of control, operation, management, maintenance and rehabilitation of the Utility System, and shall, if appropriate and if requested by the University, take all steps as may be necessary to enforce the provisions of the Operating Agreements pertaining to the surrender of the Utility System;
- (i) the University and the Concessionaire shall make appropriate adjustments, including adjustments relating to any Operating Agreements assigned to the University, Utility Fee and other similar charges collected on and after the Reversion Date that are incurred prior to the Reversion Date, and utilities, and any adjustments and payment therefor shall be made by the appropriate Party on the Reversion Date, but shall be subject to readjustment if necessary because of error in matters such as information, calculation, payments and omissions that are identified within the period of 180 Days following the Reversion Date; provided, however, that the University and the Concessionaire acknowledge that certain adjustments or readjustments may have to be made when a third party provides to the University or the Concessionaire a final adjustment amount in respect of a matter, and for such matters the adjustment and readjustment date shall each be correspondingly extended;
- (j) if this Agreement is terminated as a result of an Adverse Action, the payment by the University to the Concessionaire of the amounts required under Article 14 or Article 18 shall constitute full and final settlement of any and all Claims the Concessionaire may have against the University for and in respect of the termination of this Agreement and upon such payment, the Concessionaire shall execute and deliver all such releases and discharges as the University may reasonably require to give effect to the foregoing; and
- (k) all plans, drawings, specifications and models prepared in connection with construction at the Utility System and in the Concessionaire's possession and all "as-built" drawings shall become the sole and absolute property of the University, and the Concessionaire shall promptly deliver to the University all

such plans, drawings, specifications and models and all such as-built drawings (but may keep copies of those plans, drawings, specifications and models that were developed by the Concessionaire or its Representatives).

This Section 16.3 shall survive the expiration or any earlier termination of this Agreement.

Section 16.4. Termination Other than Pursuant to Agreement. If this Agreement is terminated by the University other than pursuant to Section 16.1, or is canceled, rescinded or voided during the Term for any reason over the objection and without action by the Concessionaire, the University shall (without limiting any payment obligations set forth in Section 15.3(f)) pay to the Concessionaire (A) the Utility System Concession Value as of the date of such termination, cancellation, rescinding or voiding, plus, without duplication, (B) the unpaid Concession and KPI Compensation Balance (for the avoidance of doubt, including any Unrecovered Balances), ~~and~~ (C) the out-of-pocket and documented costs and expenses incurred by the Concessionaire or the Operator as a direct result of such termination, cancellation, rescinding or voiding, and (D) any Taxes payable by the Concessionaire on the foregoing (A) through (C) that exceed the Taxes the Concessionaire would have paid on future receipts of the Utility Fee if the termination of this Agreement pursuant to this Section 16.4 had not occurred (using the Tax rates in effect when such damages would be payable) and using the same assumptions for the calculation of the amount of such future receipts as are used in the calculation of Utility System Concession Value. The University hereby acknowledges and agrees that it may only terminate this Agreement in accordance with the express terms hereof and shall not, in any event, have the right to terminate this Agreement for convenience. The Concessionaire hereby acknowledges and agrees that it may only terminate this Agreement in accordance with the express terms hereof and shall not, in any event, have the right to terminate this Agreement for convenience or to challenge the validity or enforceability of this Agreement.

ARTICLE 17

RESTRICTIONS ON TRANSFERS

Section 17.1. Transfers by the Concessionaire.

- (a) Subject in all respects to the collateral assignment of the Concessionaire Interest to the Leasehold Mortgagee, and exercise by the Leasehold Mortgagee of its rights pursuant to such assignment, including by foreclosure, as set forth in Article 19, the Concessionaire shall not Transfer, or otherwise permit the Transfer, of any part of the Concessionaire Interest to or in favor of a Transferee (other than a Transferee that is an Affiliate or a Leasehold Mortgagee under or nominee/designee of a Leasehold Mortgagee under Article 19) that would result in the Concessionaire directly owning 50% or less of the Concessionaire Interest granted to the Concessionaire as of the ~~date hereof~~ Signing Date unless (i) the University has Approved (based upon a determination in accordance with Section 17.1(b)) such proposed Transferee and (ii) the proposed Transferee (other than a Transferee that is an Affiliate or a Leasehold Mortgagee under Article 19) enters into an agreement with the University in form and substance satisfactory to the University, acting reasonably, wherein the Transferee acquires

the rights and assumes the obligations of the Concessionaire and agrees to perform and observe all of the obligations and covenants of the Concessionaire under this Agreement. Any Transfer made in violation of the foregoing provision shall be null and void ab initio and of no force and effect.

- (b) Approval of a proposed Transfer may be withheld if the University reasonably determines that (i) such proposed Transfer is prohibited by applicable Law, (ii) such proposed Transferee's entering into this Agreement with the University is prohibited by Law, (iii) such proposed Transfer would result in a violation of Law, (iv) such proposed Transfer would result in a Tax liability to the University (unless the University shall have received indemnification, as determined in the University's discretion, with respect thereto), or (v) such proposed Transferee is not capable of performing the obligations and covenants of the Concessionaire under this Agreement. Such determination shall be based upon and take into account the following factors, in each case assessed as of the date of such determination but after giving effect to the proposed Transfer together with any related transactions (including the proposed transfer of employees and other resources to such Transferee in connection with such proposed Transfer and related transactions): (a) the financial strength and integrity of the proposed Transferee, its direct or indirect beneficial owners, any proposed managers or operating partners and each of their respective Affiliates; (b) the experience of the proposed Transferee or the Operator engaged by the proposed Transferee in operating a Comparable Utility System and performing other relevant projects; (c) the background and reputation of the proposed Transferee, its direct or indirect beneficial owners, any proposed managers or operating partners, each of their respective officers, directors and employees and each of their respective Affiliates (including the absence of criminal, civil or regulatory claims or actions against any such Person and the quality of any such Person's past or present performance on other projects); and (d) the Operator engaged by the proposed Transferee, including the ability of the Operator to meet the Performance Standards. If the Concessionaire disputes the University's determination under this Section 17.1(b), such dispute shall be resolved in accordance with Article 18.
- (c) If requested by the Concessionaire, the University shall, on a confidential basis (unless disclosure is required by applicable Law) and at the Concessionaire's sole cost and expense, evaluate one or more proposed Transferees as provided in Section 17.1(b) and notify the Concessionaire within 30 Business Days of its Approval or withholding of Approval with respect to such proposed Transferee(s).
- (d) No Transfer of all or any of the Concessionaire Interest (except for a Transfer to a Leasehold Mortgagee or its nominee upon its exercise of remedies under the Leasehold Mortgage and any subsequent transfer to the transferee of the Leasehold Mortgagee that has been Approved under Section 17.1(b)) shall be made or have any force or effect if, at the time of such Transfer there has occurred a Concessionaire Default that has not been remedied or an event that

with the lapse of time, the giving of notice or otherwise would constitute a Concessionaire Default.

- (e) A Change in Control of the Concessionaire (other than a Change in Control occasioned by the exercise by any Leasehold Mortgagee of its remedies under any pledge of shares, limited liability company interest or partnership interest) shall be deemed to be a Transfer of the Concessionaire Interest for purposes of the foregoing provisions (thus requiring the University's Approval) and shall be evaluated by the University as provided in Section 17.1(b) and Section 17.1(c).
- (f) Nothing contained in the foregoing shall be deemed to prohibit or limit the Concessionaire from changing its name, organizational form or status (including a change from a limited liability company to a corporation or limited partnership), provided that such change in name, organizational form or status does not result in a Change in Control of the Concessionaire.
- (g) Neither (i) a change of ownership that is attributable to a lease, sublease, concession, management agreement, operating agreement or other similar arrangement that is subject and subordinate in all respects to the rights of the University under this Agreement so long as (A) no "Change in Control" occurs with respect to the Concessionaire and (B) the Concessionaire remains obligated under this Agreement, nor (ii) the creation of a trust or any other transaction or arrangement that is solely a transfer of all or part of the Concessionaire's economic interest under this Agreement to another entity shall be deemed to be a Transfer of the Concessionaire Interest for purposes of Section 17.1(a).

Section 17.2. Assignment by the University. The University shall have the right to Transfer any or all of its interest in the Utility System and this Agreement, provided that it shall be jointly and severally liable with the Transferee for the performance and observance of the obligations and covenants of the University under this Agreement, and any agreement entered into by the University under this Agreement (including agreeing directly with any Leasehold Mortgagee to be bound by the agreement entered into in accordance with Section 19.3) and that any such Transfer by the University shall not materially limit or reduce any of the Concessionaire's other rights, benefits, remedies or privileges under this Agreement nor shall it materially impair the University's ability to meet its obligations under this Agreement and, provided further, any such Transfer shall be subject to the rights and Encumbrances of the Concessionaire and of the Leasehold Mortgagee under any Leasehold Mortgage.

ARTICLE 18 DISPUTE RESOLUTION

Section 18.1. Scope. Any dispute arising out of, relating to, or in connection with this Agreement shall be resolved as set forth in this Article 18.

Section 18.2. Informal Dispute Resolution Procedures. The Parties shall attempt in good faith to resolve such dispute within 15 Business Days following receipt by one Party of notice of such dispute from the other Party. If the Parties are unable to resolve the dispute within

such period of 15 Business Days, and upon notice by either Party to the other, the dispute shall be referred to the Designated Senior Person of each Party. The Designated Senior Persons shall negotiate in good faith to resolve the dispute, conferring as often as they deem reasonably necessary. Statements made by Representatives of the Parties during the dispute resolution procedures set forth in this Section 18.2 and in Section 18.3 and documents specifically prepared for such dispute resolution procedures shall be considered part of settlement negotiations and shall not be admissible as evidence in any litigation proceeding between the Parties without the mutual consent of the Parties.

Section 18.3. Dispute Resolution.

Section 18.3(a) *Mediation.* Mediation of a dispute under this Agreement may not be commenced until the earlier of: (i) such time as both of the Designated Senior Persons, after following the procedures set forth in Section 18.2, conclude in good faith that amicable resolution through continued negotiation of the matter does not appear likely; or (ii) 15 Business Days after the notice referring the dispute to the Designated Senior Persons, pursuant to Section 18.2. If, after such time period, the dispute remains unresolved, the Parties shall attempt to resolve the dispute through mediation administered by the AAA under its Commercial Mediation Procedures before resorting to litigation, as provided by Section 18.4. The Parties agree that any period of limitation applicable to the assertion of a claim shall be deemed tolled during the conduct of informal dispute resolution under Section 18.2 and mediation under this Section 18.3(a), and that any claim of any Party shall be deemed not to have accrued until the mediation is terminated.

(b) *Expedited Arbitration.* Notwithstanding anything in Section 18.3(a) above, if the informal dispute resolution procedures set forth in Section 18.2 above fail to resolve a dispute relating to (i) the Concessionaire's determination of commercial unavailability made in accordance with Section 13.3(o) and Section 13.3(u), or (ii) the Concessionaire's assessment of the type of casualty made in accordance with Section 13.4(a)(ii) as between the University and the Concessionaire, provided that, for the avoidance of doubt, State Risk's determination as to whether a casualty is a State Risk Retained Casualty shall not be subject to challenge by either Party; within thirty (30) days of the commencement of such negotiation, or if prior to the expiration of such thirty (30)-day period the parties determine that continuation of the negotiation process is not warranted, the dispute shall be submitted to binding arbitration pursuant to the Rules of Arbitration of the AAA. The arbitration shall be heard and determined by a panel of three (3) arbitrators, one of whom shall be selected by each Party, and the third of whom shall be appointed by the mutual agreement of the two (2) arbitrators selected by the parties. Should the arbitrators be unable to agree upon the third arbitrator, then the third arbitrator shall be appointed by the AAA. The arbitration shall be held in Moscow, Idaho. The award rendered by arbitration shall be final, binding and non-appealable judgment and the award may be entered in the state courts in the State of Idaho in Latah County. Special, consequential or punitive damages shall not be awarded by the arbitrator. The

Concessionaire shall initially pay the fees of the arbitrators. Any party found by the arbitrators to have substantially prevailed on the merits of the claims shall pay the costs of the arbitrators incurred in connection with the expedited arbitration process.

Section 18.4. Litigation. Unless the Parties otherwise agree, if mediation as set forth in Section 18.3(a) does not resolve the dispute within 30 Business Days following a reference to mediation or such longer period as the Parties may mutually agree, then the Parties shall present the dispute to such court of competent jurisdiction as set forth in Section 20.7.

Section 18.5. Provisional Remedies. No Party shall be precluded from initiating a proceeding in a court of competent jurisdiction for the purpose of obtaining any emergency or provisional remedy to protect its rights that may be necessary and that is not otherwise available under this Agreement or to enforce or execute upon a judgment entered in accordance with this Agreement, including temporary, preliminary and permanent injunctive relief and restraining orders, writs of mandamus, and the appointment of a receiver or receiver and manager in connection with the collection and retention of the Utility Fee.

Section 18.6. Tolling. If a Party receiving a notice of default under this Agreement contests, disputes or challenges the propriety of such notice by making application to the dispute resolution procedure in this Article 18, any cure period that applies to such default shall be tolled for the time period between such application and the issuance of a final award or determination.

ARTICLE 19 LENDERS

Section 19.1. Leasehold Mortgages. The Concessionaire shall have the right, at its sole cost and expense, to grant one or more Leasehold Mortgages, secured by the Concessionaire Interest or the Utility Fee if at the time any such Leasehold Mortgage is executed and delivered to the Leasehold Mortgagee, no Concessionaire Default exists and upon and subject to the following terms and conditions:

- (a) a Leasehold Mortgage may not cover any property of, or secure any debt issued or guaranteed by, any Person other than the Concessionaire or the Concessionaire's Parent, but may cover shares or equity interests in the capital of the Concessionaire and any cash reserves or deposits held in the name of the Concessionaire;
- (a) no Person other than an Institutional Lender shall be entitled to the benefits and protections accorded to a Leasehold Mortgagee in this Agreement; provided, however, that lessors and lenders to the Concessionaire (and lenders to a Leasehold Mortgagee that is a Lessor) may be Persons other than Institutional Lenders so long as any Leasehold Mortgage securing the loans made by such Persons is held by an Institutional Lender acting as collateral agent or trustee;
- (b) no Leasehold Mortgage or other instrument purporting to mortgage, pledge, encumber, or create a lien, charge or security interest on or against any or all of the Concessionaire Interest shall extend to or affect the fee simple interest in the

Utility System, the University's interest hereunder or the University's reversionary interests and estates in and to the Utility System or any part thereof; in addition, any termination of this Agreement, following the expiration of the Leasehold Mortgagee's cure period in Section 19.3, if any, without a cure, by the University shall simultaneously terminate the Leasehold Mortgage; provided, however, such termination of the Leasehold Mortgage and the Concessionaire's leasehold interest in the Utility System, shall not affect, modify or terminate the Concessionaire's obligations to the Leasehold Mortgagee with respect to the Leasehold Mortgage Debt;

- (c) the University shall have no liability whatsoever for payment of the principal sum secured by any Leasehold Mortgage, or any interest accrued thereon or any other sum secured thereby or accruing thereunder, and, except for violation by the University of express obligations set forth herein with respect to the Leasehold Mortgagee or in any other agreement with the Leasehold Mortgagee, the Leasehold Mortgagee shall not be entitled to seek any damages or other amounts against the University for any or all of the same;
- (d) the University shall have no obligation to any Leasehold Mortgagee in the enforcement of the rights and remedies of the University under this Agreement or by Law, except as expressly set forth in this Agreement or in any agreement with the Leasehold Mortgagee and unless such Leasehold Mortgagee has provided the University with notice of its Leasehold Mortgage in accordance with the Leasehold Mortgagee Notice Requirements;
- (e) each Leasehold Mortgage shall provide that if the Concessionaire is in default under the Leasehold Mortgage and the Leasehold Mortgagee gives notice of such default to the Concessionaire, then the Leasehold Mortgagee shall give written notice of such default to the University;
- (f) subject to the terms of this Agreement and the terms of any direct consent agreement executed by and between the University and Leasehold Mortgagee, all rights acquired by a Leasehold Mortgagee under any Leasehold Mortgage shall be subject and subordinate to all of the provisions of this Agreement and to all of the rights of the University hereunder and the Leasehold Mortgagee shall agree to be bound by the terms of this Agreement to the extent applicable to the Leasehold Mortgagee;
- (g) notwithstanding any enforcement of the security of any Leasehold Mortgage, the Concessionaire shall remain liable to the University for the payment of all sums owing to the University under this Agreement and the performance and observance of all of the Concessionaire's covenants and obligations under this Agreement;
- (h) a Leasehold Mortgagee shall not, by virtue of its Leasehold Mortgage, acquire any greater rights or interest in the Utility System than the Concessionaire has at any applicable time under this Agreement, other than such rights granted

expressly to such Leasehold Mortgagee pursuant to this Article 19, and each Leasehold Mortgagee, the University and the Concessionaire shall enter into a consent agreement in a form acceptable to all parties; provided that such consent agreement shall be in a customary form and shall include the rights and protections provided to the Leasehold Mortgagees in this Agreement;

- (i) a Leasehold Mortgagee shall, within ~~ten (10) days~~ Days after receipt of written request from the University, execute an amendment to its recorded Leasehold Mortgage to conform the legal description of the real property encumbered by such Leasehold Mortgage to conform to the legal description in the Memorandum of Lease to the extent properly modified pursuant to Section 2.8; and
- (j) a Leasehold Mortgagee shall, within ~~ten (10) days~~ Days after receipt of written request from the University, execute documentation reasonably acceptable to the University releasing any land or other real property owned by the University from the lien of any Leasehold Mortgage such that such land or real property may be conveyed to a third party without being subject to this Agreement or the Leasehold Mortgage, provided such request is accompanied by an affidavit from the University that such land or other real property does not contain any Utility Facilities or Utility System Assets.

While any Leasehold Mortgage is outstanding, the University shall not agree to any amendment or modification of this Agreement that could reasonably be expected to have a material adverse effect on the rights or interests of the Leasehold Mortgagee or agree to a voluntary surrender or termination of this Agreement by the Concessionaire without the consent of the Leasehold Mortgagee.

Section 19.2. Notices and Payments to Leasehold Mortgagees. Whenever a Leasehold Mortgage exists as to which the University has been provided notice by the holder thereof in accordance with the Leasehold Mortgagee Notice Requirements, the University shall, simultaneously with providing the Concessionaire any required notice under this Agreement, provide a copy of such notice to such Leasehold Mortgagee, and no such notice to the Concessionaire shall be effective against the Leasehold Mortgagee until a copy thereof is duly provided to such Leasehold Mortgagee at its address specified in its notice given to the University in accordance with the Leasehold Mortgagee Notice Requirements (or any subsequent change of address notice given to the University pursuant to the requirements of Section 20.1). With respect to a Leasehold Mortgage regarding which the University has been provided notice in accordance with the Leasehold Mortgagee Notice Requirements, unless the Leasehold Mortgagee has otherwise advised the University in writing, all payments to the Concessionaire to be made by the University under this Agreement shall be made to the institution acting as the collateral agent or depository under the financing secured by such Leasehold Mortgage to the extent the University has been provided the name and mailing address of such institution.

Section 19.3. Leasehold Mortgagee's Right to Cure. The Leasehold Mortgagee shall have a period of 90 Days with respect to any Concessionaire Default beyond any cure period

expressly provided to the Concessionaire herein, in which to cure or cause to be cured any such Concessionaire Default; provided, however, that such 90-Day period shall be extended if the Concessionaire Default may be cured but cannot reasonably be cured within such period of 90 Days, and the Leasehold Mortgagee begins to cure such default within such 90-Day period (or if possession is necessary in order to effect such cure, the Leasehold Mortgagee files the appropriate legal action to commence foreclosure on the liens of the Leasehold Mortgage (or takes other appropriate action to effect a transfer of title to the property subject to such liens) and take possession of the Utility System within such period) and thereafter proceeds with all due diligence to cure such Concessionaire Default (including by proceeding with all due diligence to effect such foreclosure and during such foreclosure action (to the extent practicable) and thereafter to effect such a cure) within a reasonable period of time acceptable to the University, acting reasonably; provided further that if a Leasehold Mortgagee's right to cure a Concessionaire Default has not expired, and the Leasehold Mortgagee is acting to cure such Concessionaire Default in accordance with this Section 19.3, then the University shall not exercise its right to terminate this Agreement by reason of such Concessionaire Default. In furtherance of the foregoing, the University shall permit the Leasehold Mortgagee and its Representatives the same access to the Utility System as is permitted to the Concessionaire hereunder. The University shall accept any such performance by a Leasehold Mortgagee as though the same had been done or performed by the Concessionaire. Any payment to be made or action to be taken by a Leasehold Mortgagee hereunder as a prerequisite to keeping this Agreement in effect shall be deemed properly to have been made or taken by the Leasehold Mortgagee if such payment is made or action is taken by a nominee, agent or assignee of the rights of such Leasehold Mortgagee. Any exercise of the Leasehold Mortgagee's rights to cure hereunder shall not result in the assumption by such Leasehold Mortgagee of the Concessionaire's obligations hereunder.

Section 19.4. Rights of the Leasehold Mortgagee.

- (a) Subject to the provisions of this Agreement, a Leasehold Mortgagee may (i) enforce its Leasehold Mortgage in any lawful way, (ii) acquire the Concessionaire Interest in any lawful way, or (iii) take possession of in any lawful way and manage the Utility System in accordance with the terms of this Agreement. Upon foreclosure of (or without foreclosure upon exercise of any contractual or statutory power of sale under such Leasehold Mortgage or a deed in lieu) and subject to the provisions of Article 17 (applied to the Leasehold Mortgagee as if it were the Concessionaire, except that Section 17.1(c) will not apply), a Leasehold Mortgagee may Transfer the Concessionaire Interest; provided, however, that no Transfer by a Leasehold Mortgagee shall be effective unless the Transfer is made in accordance with Section 17.1. Any Person to whom the Leasehold Mortgagee Transfers the Concessionaire Interest (including such Leasehold Mortgagee) shall take the Concessionaire Interest subject to all of the Concessionaire's obligations under this Agreement.
- (b) Except as provided in Section 19.3, unless and until a Leasehold Mortgagee (i) forecloses or has otherwise taken ownership of the Concessionaire Interest or (ii) has taken possession or control of the Concessionaire Interest, whether directly or by an agent as a mortgagee in possession or a receiver or receiver and

manager has taken possession or control of the Concessionaire Interest by reference to the Leasehold Mortgage, the Leasehold Mortgagee shall not be liable for any of the Concessionaire's obligations under this Agreement or be entitled to any of the Concessionaire's rights and benefits contained in this Agreement, except by way of security; provided, however, that the Leasehold Mortgagee shall be entitled to cure any Concessionaire Default that requires payment of money by paying such money on the Concessionaire's behalf, prior to the Leasehold Mortgagee taking possession, control or ownership of the Concessionaire Interest. If the Leasehold Mortgagee itself or by an agent or a receiver or a receiver and manager is the owner, or is in control or possession of, the Concessionaire Interest, it shall be bound by all liabilities and obligations of the Concessionaire under this Agreement (including the obligation to engage an Operator). Once the Leasehold Mortgagee goes out of possession or control of the Concessionaire Interest or Transfers the Concessionaire Interest to another Person in accordance with the provisions of this Agreement, the Leasehold Mortgagee shall cease to be liable for any of the Concessionaire's obligations under this Agreement accruing thereafter and shall cease to be entitled to any of the Concessionaire's rights and benefits contained in this Agreement, except, if the Leasehold Mortgage remains outstanding, by way of security.

Section 19.5. Termination of this Agreement; New Agreement.

- (a) Without prejudice to the rights of a Leasehold Mortgagee under Section 19.3, if this Agreement is terminated prior to the expiration of the Term due to a Concessionaire Default (in which case the University shall notify the Leasehold Mortgagee of such termination) or if this Agreement is rejected or disaffirmed pursuant to any bankruptcy Law or proceeding or other similar Law or proceedings affecting creditors' rights generally with respect to a bankruptcy proceeding relating to the Concessionaire or otherwise, the University agrees to enter into a new concession and lease agreement of the Utility System with the Leasehold Mortgagee (or its designee or nominee, provided that such designee or nominee either is controlled by the Leasehold Mortgagee (or by the holders of the Leasehold Mortgage Debt)) or is Approved by the University as Transferee under Section 17.1) for the remainder of the original stated Term upon all of the covenants, agreements, terms, provisions and limitations of this Agreement, without any charge, penalty, assessment or consideration not specifically provided for in this Section 19.5 (the "New Agreement"), effective as of the date of such termination, but only on and subject to the satisfaction of all of the following requirements and conditions: (i) such Leasehold Mortgagee commits in writing to the University, in a notice delivered to the University, within 30 Days after the University delivers the termination notice to Leasehold Mortgagee (or, if later, upon the termination of any cure period granted to the Leasehold Mortgagee pursuant to Section 19.3) or within 30 Days after the effective date of such rejection or disaffirmance, as the case may be, that the Leasehold Mortgagee (or its designee or nominee) will enter into the New Agreement, which notice is accompanied by a copy of such New Agreement, duly executed and acknowledged by the Leasehold Mortgagee (or its designee or nominee);

- (ii) the Leasehold Mortgagee (or its designee or nominee) pays or causes to be paid to the University, at the time of the execution and delivery of the New Agreement, all amounts which, at the time of the execution and delivery thereof, would have been past-due or due and payable in accordance with the provisions of this Agreement but for such termination; (iii) provided the University furnishes a statement or invoice for such costs the Leasehold Mortgagee pays or causes to be paid to the University all reasonable costs and expenses (including legal, advisory and other fees), Taxes, fees, charges and disbursements paid or incurred by the University in connection with such Concessionaire Defaults and termination, the recovery of possession from the Concessionaire, and in connection with the preparation, execution and delivery of the New Agreement and related agreements and documents specified in such statement or invoice; and (iv) such Leasehold Mortgagee (or its designee or nominee), at the time of such written request, cures all Concessionaire Defaults under this Agreement (curable by the payment of money) existing immediately prior to the termination of this Agreement, or, if such Concessionaire Defaults cannot be cured by the payment of money, such Leasehold Mortgagee (or its designee or nominee) commits to the University in the New Agreement to proceed both promptly and diligently, upon the execution of the New Agreement, to cure all such other Concessionaire Defaults to the extent such Concessionaire Defaults are capable of cure by a Person other than the original Concessionaire and, if possession is necessary in order to cure such other Concessionaire Defaults, to proceed both promptly and diligently to obtain the possession required to cure any such other Concessionaire Defaults (and such cure shall be a covenant in the New Agreement).
- (b) Nothing contained in this Section 19.5 shall be deemed to limit or affect the University's interests in and to such Utility System upon the expiration of the Term of the New Agreement. The provisions of this Section 19.5 shall survive the termination of this Agreement and shall continue in full force and effect thereafter to the same extent as if this Section 19.5 were a separate and independent contract made by the University, the Concessionaire and the Leasehold Mortgagee and, if the Leasehold Mortgagee satisfies the conditions to execute a New Agreement, from the effective date of such termination of this Agreement to the date of execution and delivery of the New Agreement, the Leasehold Mortgagee may use and enjoy the leasehold estate created by this Agreement without hindrance by the University, but only on and subject to the terms and provisions of this Agreement.
- (c) If the circumstances described in Section 19.5(a) occur, and the University determines, based on the written legal advice of counsel, that termination of this Agreement and the entry into a New Agreement by and among the University and the Leasehold Mortgagee could violate applicable provisions of the Laws of the State of Idaho governing procurement by the University then, in lieu of entering in a New Agreement and in satisfaction of its obligations under this

Section 19.5, the University agrees to enter into an Assignment and Assumption Agreement pursuant to Section 19.8.

Section 19.6. Recognition of Leasehold Mortgagee. If there is more than one Leasehold Mortgagee, only that Leasehold Mortgagee (who, for the avoidance of doubt, may act on behalf of one or more lender groups as contemplated by Section 19.1), to the exclusion of all other Leasehold Mortgagees, whose notice was earliest received by the University pursuant to the Leasehold Mortgagee Notice Requirements, shall have the right to exercise the rights as a Leasehold Mortgagee under this Article 19 vis-à-vis the University, unless such Leasehold Mortgagee has designated in writing another Leasehold Mortgagee to exercise such rights in which case the other Leasehold Mortgagee may exercise such rights, provided that such requirement shall not limit such additional Leasehold Mortgagees' rights hereunder. Such Leasehold Mortgagee may act as agent for a group or syndicate of one or more Institutional Lenders and such Leasehold Mortgagee and Institutional Lenders may freely assign or sell interests and/or participations in the loans to any other Institutional Lender.

Section 19.7. University's Right to Purchase Leasehold Mortgages.

- (a) If any default by the Concessionaire has occurred under a Leasehold Mortgage and has not been cured within applicable cure periods, or any act, condition or event has occurred which would permit a Leasehold Mortgagee to declare all or part of the indebtedness secured by a Leasehold Mortgage to be immediately due and payable (or, in the case of a Leasehold Mortgage that is a lease, to terminate the lease), then the University shall have 30 Days after the date on which such Leasehold Mortgagee shall serve notice upon the University in writing ("Leasehold Mortgagee's Notice") that such Leasehold Mortgagee intends to commence proceedings to foreclose the Leasehold Mortgage or, in the case of a Leasehold Mortgage that is a Lessor to terminate the lease with the Concessionaire (stating the calculation of the purchase price pursuant to Section 19.7(c)), during which 30-Day period the University shall have the right and option (the "University's Option") to purchase from all Leasehold Mortgagees their Leasehold Mortgages, upon the terms and subject to the conditions contained in this Section 19.7.
- (b) The University's Option shall be exercised by notice served upon the Concessionaire and all Leasehold Mortgagees within such 30-Day period. If the University's Option is duly and timely exercised, the University shall purchase and all Leasehold Mortgagees shall assign their Leasehold Mortgages to the University (or its designee) on the date which is 60 Days after the date on which a Leasehold Mortgagee's Notice is served upon the University. The closing shall take place at a mutually convenient time and place.
- (c) The purchase price payable by the University shall be equal to the aggregate amounts secured by such Leasehold Mortgages (including principal, interest, fees, premiums, Breakage Costs and other costs, expenses (including attorneys' fees) and any other amounts secured thereby) as of the closing date of the purchase. The purchase price shall be paid in full in cash at closing by wire

transfer or other immediately available funds. The purchase price shall be paid by the University to each respective Leasehold Mortgagee, to be applied by the Leasehold Mortgagee to the amounts secured by the Leasehold Mortgage owed to such Leasehold Mortgagee, subject to the priorities of lien of such Leasehold Mortgages.

- (d) At the closing and upon payment in full of the purchase price each Leasehold Mortgagee shall assign its Leasehold Mortgage to the University, together with any security interest held by it in the Concessionaire Interest, without recourse, representations, covenants or warranties of any kind, provided that such Leasehold Mortgages and security interests shall be deemed modified to secure the amount of the aggregate purchase price paid by the University to all Leasehold Mortgagees (rather than the indebtedness theretofore secured thereby) payable on demand, with interest and upon the other items referred to in this Section 19.7(d). Each such assignment shall be in form for recordation or filing, as the case may be. The University shall be responsible for paying any Taxes payable to any Governmental Authority upon such assignment. Such assignment shall be made subject to such state of title of the Utility System as shall exist at the date of exercise of the University's Option.
- (e) Any Leasehold Mortgage shall contain an agreement of the Leasehold Mortgagee to be bound by the provisions of this Section 19.7, and the University shall have the right to receive all notices of default under any Leasehold Mortgage.

Section 19.8. Assignment and Assumption Agreement.

- (a) The provisions of this Section 19.8 shall be in effect whenever either (i) the University has made the determination contemplated by Section 19.5(c) or (ii) the University, with the written consent of the Leasehold Mortgagee, has determined to proceed under this Section 19.8 in lieu of under Section 19.5.
- (b) Without prejudice to the rights of a Leasehold Mortgagee under Section 19.3, if either (i) the University has given a notice of termination of this Agreement due to Concessionaire Default pursuant to Section 16.1(b), or (ii) this Agreement is rejected or disaffirmed pursuant to any bankruptcy Law or proceeding or other similar Law or proceedings affecting creditors' rights generally with respect to a bankruptcy proceeding relating to the Concessionaire or otherwise, the University agrees to cooperate with a Leasehold Mortgagee in order to effectuate such Leasehold Mortgagee's rights under the Leasehold Mortgage to step-in, assume or assign this Agreement, in accordance with the procedures, terms and conditions of this Section 19.8 without any charge, penalty, assessment or consideration not specifically provided for in this Section 19.8.
- (c) Upon notification and satisfaction of all of the conditions and requirements in Section 19.8(d), the University agrees that this Agreement shall not be deemed terminated, but may be assumed by a Leasehold Mortgagee or by a designee or

nominee of such Leasehold Mortgagee who is either controlled by the Leasehold Mortgagee (or by the holders of the Leasehold Mortgage Debt) or is Approved by the University as a Transferee under Section 17.1, for the remainder of the original stated Term of this Agreement, and as evidence of such assignment and assumption the University agrees to execute an amended and restated concession and lease agreement for the Utility System upon all of the covenants, agreements, terms, provisions and limitations of this Agreement (the "Assignment and Assumption Agreement").

(d) This Agreement may be so assigned and assumed pursuant to an Assignment and Assumption Agreement upon and subject to satisfaction of all of the following requirements and conditions:

- (i) Suehsuch Leasehold Mortgagee must commit in writing to the University, in a notice delivered to the University within the later of 30 Days after the University delivers the termination notice to Leasehold Mortgagee or upon the termination of any cure period granted to such Leasehold Mortgagee pursuant to Section 19.3, or within 30 Days after the effective date of any rejection or disaffirmance of this Agreement in a bankruptcy proceeding, as the case may be, that such Leasehold Mortgagee (or its designee or nominee) will assume this Agreement and enter into the Assignment and Assumption Agreement, which notice is accompanied by a copy of such Assignment and Assumption Agreement duly executed and acknowledged by such Leasehold Mortgagee (or its designee or nominee);
- (ii) Suehsuch Leasehold Mortgagee (or its designee or nominee) shall pay or cause to be paid to the University, at the time that the Assignment and Assumption Agreement is fully executed, all amounts which, at the time of the execution and delivery thereof, would have been past-due or due and payable in accordance with the provisions of this Agreement;
- (iii) Suehsuch Leasehold Mortgagee (or its designee or nominee) shall pay or cause to be paid to the University all reasonable costs and expenses (including legal fees), Taxes, fees, charges and disbursements paid or incurred by the University in connection with such defaults and notice of termination, the recovery of possession from the Concessionaire, and in connection with the preparation, execution and delivery of the Assignment and Assumption Agreement and related agreements and documents. The University shall provide an invoice to such Leasehold Mortgagee of such costs, and the Leasehold Mortgagee or its designee or nominee shall pay such invoiced costs within 5 Days of the receipt of such invoice; and
- (iv) Suehsuch Leasehold Mortgagee (or its designee or nominee), at the time of the notice provided under Section 19.8(d)(i), shall cure all Concessionaire Defaults under this Agreement (including all such Concessionaire Defaults curable by the payment of money) existing

immediately prior to the notice of termination issued pursuant to Section 16.1(b), or, if such Concessionaire Defaults cannot be cured by the payment of money, such Leasehold Mortgagee (or its designee or nominee) shall commit to the University in the Assignment and Assumption Agreement to proceed both promptly and diligently, upon the execution of the Assignment and Assumption Agreement, to cure all such other defaults to the extent such defaults are capable of cure by a Person other than the original Concessionaire and, if possession is necessary in order to cure such other Concessionaire Defaults, to proceed both promptly and diligently to obtain the possession required to cure any such other defaults (and such obligation to cure shall be a covenant in the Assignment and Assumption Agreement).

- (e) If a Leasehold Mortgagee gives the University a notice as provided in Section 19.8(d)(i), the University and Leasehold Mortgagee agree to cooperate with respect to taking any appropriate actions required to regain and transfer possession of the Utility System and the Utility System Assets, including: (i) seeking surrender of possession in any bankruptcy proceedings; and (ii) seeking relief from any automatic stay in bankruptcy provisions and pursuit of state law remedies to obtain possession and to foreclose on the Leasehold Mortgage interest and assume the Concessionaire's position as provided in Section 19.4 of this Agreement; provided that any costs incurred by the University under this provision shall be reimbursed by the Leasehold Mortgagee (or its designee or nominee) as provided in Section 19.8(d)(iii).

Section 19.9. Right to Dispute Resolution. In each case specified in this Agreement in which resort to dispute resolution is authorized, a Leasehold Mortgagee shall have the right and privilege if an event of default under the Leasehold Mortgage then exists and notice has been given to the University as contemplated by Section 19.1(f), in the Concessionaire's name, place and stead, to obtain and participate in such dispute resolution upon notice to the University in accordance with Article 18; provided that the Leasehold Mortgagee agrees to be bound by the outcome of the dispute resolution process.

ARTICLE 20 MISCELLANEOUS

Section 20.1. Notice. All notices by the Concessionaire or the University, approvals or consents by the Concessionaire, and Approvals by the University (each, a "Notice") required or permitted by this Agreement shall be in writing, shall state specifically that they are being given pursuant to this Agreement and shall be delivered by email, nationally recognized overnight courier service, or certified or registered mail (return receipt requested and postage prepaid) for the attention of the persons and to the addresses or email addresses shown below (or such other persons, address or email addresses as either Party may from time to time designate by a Notice to the other):

(a) in the case of the University:

(i) for delivery by mail:

University of Idaho
Office of Finance & Administration
875 Perimeter Drive MS-3168
Moscow, Idaho 83844-3168
Attention: Vice President for Finance & Administration

With a copy to:

University of Idaho
Office of the General Counsel
875 Perimeter Drive MS-3158
Moscow, Idaho 83844-3158

(ii) for delivery by email:

Vice President for Finance & Administration
Email: vpfinance@uidaho.edu

With a copy to:

Office of the General Counsel
Email: counsel@uidaho.edu

(b) in the case of the Concessionaire:

(i) for delivery by mail:

Sacyr Infrastructure USA LLC
3191 Coral Way, Suite 510
Miami, Florida 33145
Attention: Raúl Perez Lopez

With a copy to:

Plenary Americas LP
Suite 2000, 400 Burrard Street
Commerce Place
Vancouver BC V6C 3A6
Attention: Matthew Coady

With a copy to:

Hunton Andrews Kurth LLP
2200 Pennsylvania Avenue NW
Washington, D.C. 20037
Attention: David B. Horner, Esq.

(ii) for delivery by email:

Raúl Perez Lopez
Email: rperezl@sacyr.com

With a copy to:

Matthew Coady
Email: Matt.Coady@plenarygroup.com

With a copy to:

David B. Horner, Esq.
Email: DHorner@Hunton.com

A Notice shall be deemed to have been sent and received (i) on the Day it is delivered, or if such Day is not a Business Day or if the Notice is received after ordinary office hours (time of place of receipt), the Notice shall be deemed to have been sent and received on the next Business Day, or (ii) on the 4th Business Day after mailing if sent by U.S. registered or certified mail. Each Party shall use commercially reasonable efforts to deliver an electronic copy of each Notice provided by mail in accordance with the foregoing via email to the persons and email addresses designated pursuant to the foregoing to receive Notices provided by email.

All communications other than Notices that are required or permitted by this Agreement shall be in writing, shall state specifically that they are being given pursuant to this Agreement and shall be delivered by email to the persons and email addresses shown below (or such other persons or email addresses as either Party may from time to time designate by a Notice to the other):

(x) in the case of the University:

Brian Foisy
Email: brianfoisy@uidaho.edu

(y) in the case of the Concessionaire:

Raúl Perez Lopez
Email: rperezl@sacyr.com

With a copy to:

Matthew Coady
Email: Matt.Coady@plenarygroup.com

Section 20.2. Entire Agreement. This Agreement constitutes the entire agreement between the Parties pertaining to the subject matter hereof and supersedes all prior agreements, negotiations, discussions and understandings, written or oral, between the Parties. There are no representations, warranties, conditions or other agreements, whether direct or collateral, or express or implied, that form part of or affect this Agreement, or that induced any Party to enter into this Agreement or on which reliance is placed by any Party, except as specifically set forth in this Agreement. The Parties acknowledge and agree that (i) each has substantial business experience and is fully acquainted with the provisions of this Agreement, (ii) the provisions and language of this Agreement have been fully negotiated, and (iii) no provision of this Agreement shall be construed in favor of any Party or against any Party by reason of such provision of this Agreement having been drafted on behalf of one Party rather than the other.

Section 20.3. Amendment. This Agreement may be amended, changed or supplemented only by a written agreement signed by the Parties.

Section 20.4. Waiver of Rights. Any waiver of, or consent to depart from, the requirements of any provision of this Agreement shall be effective only if it is in writing and signed by the Party giving it, and only in the specific instance and for the specific purpose for which it has been given. No failure on the part of any Party to exercise, and no delay in exercising, any right under this Agreement shall operate as a waiver of such right. No single or partial exercise of any such right shall preclude any other or further exercise of such right or the exercise of any other right.

Section 20.5. Severability. Each provision of this Agreement shall be valid and enforceable to the fullest extent permitted by applicable Law. The invalidity of any one or more phrases, sentences, clauses or sections contained in this Agreement shall not affect the remaining portions of this Agreement or any part thereof. If any provision of this Agreement or the application thereof to any Person or circumstance is held or deemed to be or determined to be invalid, inoperative or unenforceable in any particular case in any particular jurisdiction or jurisdictions because it conflicts with any other provision or provisions hereof or of any applicable Law, or public policy, or for any other reason, (i) such circumstance shall not have the effect of rendering the provision in question inoperative or unenforceable in any other case or circumstance, or rendering any other provision or provisions herein contained invalid, inoperative or unenforceable to any extent whatever, and (ii) the Parties shall negotiate in good faith to amend this Agreement to implement the provisions set forth herein. If the Parties cannot agree on an appropriate amendment, either Party may refer the matter for determination pursuant to the dispute resolution procedure in Article 18. If, by means of the dispute resolution procedure, the Parties are unable, as a result of applicable Law, to resolve the matter in a manner that effectively entitles the University to have the same rights after the aforesaid determination of invalidity or unenforceability as before, the University shall have the right to enact, and cause to come into force, any Law to provide for the same or substantially the same rights as were determined to be invalid or unenforceable.

Section 20.6. Governing Law; Waiver of Jury Trial. This Agreement shall be governed by, and interpreted and enforced in accordance with, the Laws in force in the State of Idaho (excluding any conflict of laws rule or principle which might refer such interpretation to the Laws of another jurisdiction). **EACH OF THE PARTIES HEREBY IRREVOCABLY WAIVES ANY AND ALL RIGHT TO TRIAL BY JURY IN ANY LEGAL PROCEEDING ARISING OUT OF OR RELATED TO THIS AGREEMENT OR THE TRANSACTIONS CONTEMPLATED HEREBY.**

Section 20.7. Submission to Jurisdiction. Subject to Article 18, any action or proceeding against any Party relating in any way to this Agreement may be brought and enforced in the state courts in the State of Idaho in Latah County, and each of the Concessionaire and the University hereby irrevocably submits to the jurisdiction of such courts with regard to any such action or proceeding, and irrevocably waives, to the fullest extent permitted by applicable Law, any objection it may have now or hereafter have to the laying of venue of any such action or proceeding in such courts and any claim that any such action or proceeding brought in any such court has been brought in an inconvenient forum. Service of process on the University may be made, either by registered or certified mail addressed as provided for in Section 20.1. Service of process on the Concessionaire may be made either by registered or certified mail addressed as provided for in Section 20.1 or by delivery to the Concessionaire's registered agent for service of process in the State of Idaho. If the Concessionaire is presented with a request for Documents by any administrative agency or with a subpoena duces tecum regarding any Documents which may be in its possession by reason of this Agreement, the Concessionaire, unless prohibited by Law, shall give prompt notice to the University. The University may contest such process by any means available to it before such Documents are submitted to a court or other third party; provided, however, that the Concessionaire shall not be obligated to withhold such delivery beyond that time as may be ordered by the court or administrative agency or required by Law, unless the subpoena or request is quashed or the time to produce is otherwise extended.

Section 20.8. Further Acts. The Parties shall do or cause to be done all such further acts and things as may be reasonably necessary or desirable to give full effect to this Agreement. Without limiting the foregoing, each Party will, at any time and from time to time, execute and deliver or cause to be executed and delivered such further instruments and assurances and take such further actions as may be reasonably requested by the other Party in order to cure any defect in the execution and/or delivery of this Agreement.

Section 20.9. Costs. Except as otherwise provided in this Agreement, each Party shall be responsible for its own costs and expenses incurred in connection with performing and observing its obligations and covenants under this Agreement.

Section 20.10. Interest. Any amount payable under this Agreement and not paid when due shall bear interest at a variable nominal rate per annum equal on each Day to the Bank Rate then in effect, from the date such payment is due until payment and both before and after judgment.

Section 20.11. Inurement and Binding Effect. This Agreement shall inure to the benefit of the Parties and their respective permitted successors and assigns and is binding upon the Parties and their respective successors and assigns.

Section 20.12. No Partnership or Third Party Beneficiaries. Except as expressly provided herein to the contrary, nothing contained in this Agreement shall constitute or be deemed to create a partnership, joint venture or principal and agent relationship between the University and the Concessionaire, nor shall any term or provision hereof be construed in any way to grant, convey or create any rights or interests to any Person not a party to this Agreement, other than, in the case of Section 3.11, Section 10.2, Section 12.3, Section 13.4, Section 14.2, Section 16.3, Section 17.1, Section 17.2 and Article 19, any Leasehold Mortgagee.

Section 20.13. Cumulative Remedies. The rights, remedies, powers and privileges herein provided are cumulative and not exclusive of any rights, remedies, powers and privileges provided by Law, except for the remedies available to the University for a breach of the Performance Standards or a KPI Event, which shall be limited to those expressly set forth herein. Notwithstanding the foregoing, where this Agreement provides for liquidated damages, such liquidated damages shall be the sole exclusive remedy of the University or the Concessionaire, as applicable, and the University and the Concessionaire hereby irrevocably waive any right to assert a claim against the other party based on a legal theory that a remedy provided herein for such breach or act triggering the liquidated damages fails of its essential purpose.

Section 20.14. Counterparts; Electronic Execution. This Agreement may be executed in any number of counterparts which, taken together, shall constitute one and the same agreement. This Agreement shall be effective when it has been executed by each Party and delivered to both Parties. To evidence the fact that it has executed this Agreement, a Party may send a copy of its executed counterpart to the other Party by email or other means of electronic transmission. Such Party shall be deemed to have executed and delivered this Agreement on the date it sent such email or other means of electronic transmission. In such event, such Party shall forthwith deliver to the other Party an original counterpart of this Agreement executed by such Party.

Section 20.15. Time of the Essence. Time is of the essence for this Agreement.

(Intentionally Left Blank)

IN WITNESS WHEREOF, the University and the Concessionaire have caused this Agreement to be signed by their respective officers thereunto duly authorized as of the date first written above.

THE REGENTS OF THE UNIVERSITY OF
IDAHO

BY: _____
PRINTED: C. Scott Green, President of the
University of Idaho

SACYR PLENARY UTILITY PARTNERS
IDAHO LLC

By: Sacyr Plenary Idaho Holdings LLC, its sole
member and manager

BY: _____
PRINTED: Eduardo de Lara Garay
ITS: Manager

BY: _____
PRINTED: Matt Girard
ITS: Manager

Summary report:	
Litera Compare for Word 11.6.0.100 Document comparison done on 3/20/2024 1:06:52 PM	
Style name: JD Color With Moves	
Intelligent Table Comparison: Inactive	
Original DMS: iw://naiweb.firm.jonesday.net/NAI/1536325012/1	
Modified DMS: iw://naiweb.firm.jonesday.net/NAI/1536325012/21	
Changes:	
<u>Add</u>	739
Delete	399
Move From	5
<u>Move To</u>	5
<u>Table Insert</u>	0
Table Delete	0
<u>Table moves to</u>	0
Table moves from	0
Embedded Graphics (Visio, ChemDraw, Images etc.)	0
Embedded Excel	0
Format changes	0
Total Changes:	1148

FIRST AMENDED AND RESTATED SCHEDULE 2

PERFORMANCE STANDARDS

TABLE OF CONTENTS

Part I - GENERAL..... 1

Part II - PERFORMANCE STANDARDS – GENERAL OPERATIONS..... 3

 1) General..... 3

 2) Exterior Appearance of Utility Facilities..... 8

 3) Utility Marking, GIS Mapping and Asset Management..... 8

 4) Health and Safety..... 9

 5) Emergency Response and Unplanned Outages..... 10

 6) Procedures for Planned Outages..... 13

 7) Design Standards..... 13

 8) Material and Equipment Management..... 14

 9) Personnel, Operations and Reporting..... 14

 10) Environmental Compliance..... 16

 11) Utility Office Functions..... 21

 12) Interagency Cooperation and Coordination..... 21

 13) University Department Office Cooperation..... 22

 14) Public Relations and Media Interactions..... 22

 15) Vehicle Use and Operation..... 23

 16) Utility Service Inquiries..... 24

 17) Emergency Safety Plans..... ~~24~~²⁵

 18) Continuity Management Plan..... 25

 19) Information Technology, Communications and Connectivity..... 26

 20) Ongoing Utility System Projects – Cogeneration Plant..... 28

Part III - PERFORMANCE STANDARDS – CHILLED WATER SYSTEM..... 29

 1) Temperature Requirements..... 29

 2) Pressure Requirements..... 29

 3) Line of Demarcation between Concessionaire and University..... 29

 4) Metering..... 30

5)	Efficiency.....	31
6)	Design Standards.....	31
7)	Unplanned Outage.....	31
8)	Redundancy.....	32
9)	Water Quality.....	33
Part IV - PERFORMANCE STANDARDS – STEAM AND CONDENSATE SYSTEM.....		35
1)	Pressure Requirements.....	35
<u>2)</u>	<u>Ongoing Utility System Projects - Cogeneration Plant (Microturbine Generators)</u>	<u>35</u>
23)	Air Quality Permit with Idaho DEQ.....	35
34)	Line of Demarcation between Concessionaire and University.....	35 <u>36</u>
45)	Metering.....	36
56)	Efficiency.....	37
67)	Design Standards.....	37
78)	Unplanned Outage.....	38
89)	Redundancy.....	39
910)	Fuel Operations and Storage.....	40
10)	Condensate water storage.....	40
Part V - PERFORMANCE STANDARDS – ELECTRIC SYSTEM.....		41
1)	Power Requirements.....	41
2)	Line of Demarcation; Concessionaire, University, and Avista Utility.....	42 <u>41</u>
3)	Metering.....	42
4)	Efficiency.....	44
5)	Design Standards.....	44
6)	Unplanned Outage.....	44
7)	Redundancy.....	45
8)	Distribution System Switching.....	46
Part VI - PERFORMANCE STANDARDS – DOMESTIC WATER SYSTEM.....		47
1)	Regulatory Requirements.....	47
2)	Pressure Requirements.....	47
3)	Line of Demarcation between Concessionaire and University.....	48
4)	Metering.....	48
5)	Efficiency.....	49 <u>50</u>

6)	Design Standards.....	50
7)	Unplanned Outage.....	51
8)	Redundancy.....	52
9)	Water Quality.....	52
Part VII - PERFORMANCE STANDARDS – COMPRESSED AIR SYSTEM.....		53 <u>54</u>
1)	Temperature Requirements.....	53 <u>54</u>
2)	Pressure Requirements.....	53 <u>54</u>
3)	Line of Demarcation between Concessionaire and University.....	53 <u>54</u>
4)	Metering	53
54)	Efficiency.....	54
65)	Design Standards.....	54
76)	Unplanned Outage.....	54 <u>55</u>
87)	Redundancy.....	55
[Part VIII – PERFORMANCE STANDARDS – UTILITY SCADA NETWORK SYSTEM Intentionally Omitted].....		56
1)	Availability Requirements	56
2)	Line of Demarcation between Concessionaire and University	56
3)	Utility Network Components	56
4)	Unplanned Outage	57
5)	Redundancy	58
Part IX - PERFORMANCE STANDARDS – STORM WATER SYSTEM.....		59 <u>57</u>
1)	Regulatory Requirements.....	59 <u>57</u>
2)	Pressure Requirements.....	59 <u>57</u>
3)	Water Quality.....	59 <u>57</u>
4)	Line of Demarcation between Concessionaire and University.....	59 <u>57</u>
5)	Design Standards.....	60 <u>57</u>
6)	Unplanned Outage.....	60 <u>58</u>
Part X - PERFORMANCE STANDARDS – SANITARY SEWER SYSTEM.....		62 <u>60</u>
1)	Pressure Requirements.....	62 <u>60</u>
2)	Line of Demarcation between Concessionaire and University.....	62 <u>60</u>
3)	Design Standards.....	62 <u>60</u>
4)	Unplanned Outage.....	62 <u>60</u>
Part XI - PERFORMANCE STANDARDS – RECLAIMED WATER SYSTEM.....		64 <u>62</u>

1) Regulatory Requirements.....	64 <u>62</u>
2) Pressure Requirements.....	64 <u>62</u>
3) Line of Demarcation between Concessionaire and University.....	65 <u>62</u>
4) Metering.....	65 <u>63</u>
5) Efficiency.....	66 <u>64</u>
6) Design Standards.....	66 <u>64</u>
7) Unplanned Outage.....	67 <u>65</u>
8) Redundancy.....	68 <u>66</u>
9) Water Quality.....	68 <u>67</u>
LIST OF APPENDICES.....	70 <u>68</u>

Part I - GENERAL

Introduction and Purpose of Performance Standards

These Performance Standards and any Appendices thereto, are provided pursuant to Article 6 of the [First Amended and Restated](#) Long-Term Lease and Concession Agreement for the University of Idaho Utility System (as modified, amended or restated, the “[Concession Agreement](#)”) to which they are attached. The Performance Standards and Appendices are incorporated and made part of the obligations under the Concession Agreement.

The Utility System is comprised of 8 individual Utilities, specifically the: (i) the portion of the Utility System that generates, distributes and returns chilled water (the “[Chilled Water System](#)”); (ii) the portion of the Utility System that generates, distributes and returns steam, hot water, and condensate, which as of the date hereof is subject to Air Quality Tier I Operating Permit T-1-2017.0048 (the “[Steam and Condensate System](#)”); (iii) the portion of the Utility System that produces (to the extent applicable) and distributes electricity (the “[Electric System](#)”); (iv) the portion of the Utility System that distributes domestic water (the “[Domestic Water System](#)”); (v) the portion of the Utility System that produces and distributes compressed air (the “[Compressed Air System](#)”); (vi) the portion of the Utility System that removes storm water (the “[Storm Water System](#)”); (vii) the portion of the Utility System that collects sanitary sewage (the “[Sanitary Sewer System](#)”) and (viii) the portion of the Utility System that processes and delivers reclaimed, non-potable water to the campus as irrigation water, which as of the date hereof operates under the Idaho Department of Environmental Water Quality: Permit No.: WRU M-028-3 Formerly LA-000028-03 (the “[Reclaimed Water System](#)”). The purpose of the Performance Standards is to: (A) provide the minimum general requirements for the operations and maintenance of the University’s Utility System and provide standards governing Utility System Operations as required by the Concession Agreement, but are not inclusive of all of the Concessionaire’s responsibilities; (B) aid in the development of an Operations Plan (as defined herein) to be developed annually by the Concessionaire for the Utility System; (C) incentivize the Concessionaire to minimize the time during which the Utility System experiences outages; and (D) ensure that the Utility System is operated and maintained in accordance with Prudent Industry Practices.

Terms used and not otherwise defined in these Performance Standards shall have the meanings ascribed to them in the Concession Agreement (and any other schedules attached thereto). Any approvals or consent required under these Performance Standards shall be governed by the procedure outlined in Section 1.15 of the Concession Agreement. Unless otherwise stated herein or in the Concession Agreement, any modification or change to the requirements set forth in these Performance Standards or Appendices thereto, shall be governed by Section 6.3 of the Concession Agreement. Any references to a governmental entity, industry standard organization or University department shall include any successor to such entity, organization or department. Any references to “degrees” shall, unless otherwise specified herein, mean “degrees Fahrenheit.” To the extent that any term or provision specified herein conflicts with any term or provision of the Concession Agreement, the Concession Agreement shall govern.

The Concessionaire shall perform all duties and tasks and all other responsibilities required by these Performance Standards in conformance with Prudent Industry Practices, and the Concessionaire shall keep the Utility System in good condition and repair throughout the Term of the Concession Agreement. If the Concessionaire fails to meet these Performance Standards, it shall be subject to the procedures in the Concession Agreement for addressing such failures.

If deficiencies or situations affecting minimum standards for performance develop during the Term that are not specifically noted herein, it is the Concessionaire's responsibility to correct the deficiencies and manage such situations such that the Utility System will be maintained in the condition required by these Performance Standards.

Part II - PERFORMANCE STANDARDS – GENERAL OPERATIONS

1) **General**

- a) The Concessionaire shall propose a plan with respect to the Utility System in accordance with these Performance Standards and the Concession Agreement (the “Operations Plan”). The Operations Plan shall include and satisfy at a minimum, all requirements and all components of the Performance Standards and Prudent Industry Practices and shall include, in addition to the specific requirements set forth herein, the following: (1) the plan for the operation, repair, maintenance and replacement of the Utility Facilities and Utility System Assets; (2) any proposed or expected changes to the environmental permitting requirements or classifications of any portion of the Utility System for the upcoming 5 years, of which the Concessionaire has knowledge, (3) any proposed or expected requirements related to regulatory changes affecting the Utility System, of which the Concessionaire has knowledge; (4) the 1 year short term list of goals and expectations for the Utility System operations and 5 year list of strategic goals therefor as described in [Part II, Section 1\(d\) hereof](#); (5) a detailed staffing plan, as described in [Part II, Section 9\(b\) hereof](#); (6) the Building Emergency Action Plan; (7) the Continuity Management Plan; (8) a maintenance management program, as described in [Part II, Section 1\(e\) hereof](#); (9) operations and maintenance manuals for all Utility Facilities; and (10) the Operator’s standard hourly and fixed rates for performing services for the University and its Representatives that are not part of Utility System Operations, which shall be reasonable and consistent with the University’s past practice, taking into account changes in the cost of supplies, materials and labor (the “Concessionaire Charge Rates”). The Concessionaire shall submit such Operations Plan to the University for its review within 180 days after Closing and as further required herein. The University will review the Operations Plan and where appropriate, will provide comments for Concessionaire’s consideration. The Concessionaire shall perform all components of the Operations Plan. The Operations Plan shall cover each Fiscal Year. The Operations Plan must include an appropriate 5-year cyclical maintenance and repair program/plan to provide a safe and satisfactory level of service and to maximize Utility System service life in accordance with these Performance Standards. To the extent that any term or provision of the Operations Plan conflicts with any term or provision of these Performance Standards, the Performance Standards shall govern.
- b) All operations, repairs, replacement and maintenance activities shall be carried out in a good and workmanlike manner so as to ensure continuous safety for users of the Utility System and to sustain the value of the Utility System as an asset. Condition assessments and inspections shall follow Prudent Industry Practices and recognized national standards as set forth herein. If the University elects, at its sole cost and expense, to perform, or cause to be performed by a qualified engineering firm, any such assessment or inspection, then the Concessionaire covenants to address any failures to operate, repair or maintain the Utility System in accordance with these Performance Standards and the Concession Agreement,

noted therein as promptly as reasonably practicable, and the Concessionaire shall reasonably cooperate with the University and any qualified engineering firm engaged by the University.

- c) Other than as set forth in [Part II](#), Section 1(a) [hereof](#) with respect to the first Operations Plan, the Concessionaire must update and submit its Operations Plan for the upcoming Fiscal Year to the University no later than 120 days prior to the beginning of each Fiscal Year. The University will review and if necessary, comment on the Operations Plan. The Concessionaire shall submit an updated Operations Plan for the start of each Fiscal Year, which may be based on the prior Fiscal Year's Operations Plan. If the Concessionaire fails in its obligation to submit an Operations Plan by the commencement of such Fiscal Year, the Operations Plan for the preceding Fiscal Year shall remain in place until an updated Operations Plan is submitted, provided that such updated Operations Plan shall remain subject to the University's right to review and comment as set forth above. Notwithstanding the above, any proposals subject to University Approval as part of the Concessionaire's Five Year Plan, must comply with Articles 4 and 7 of the Concession Agreement.
- d) The Operations Plan shall specify how the Concessionaire has considered, trained, addressed, and planned for all operational, repair, maintenance and replacement activities in connection with the Utility System and has established protocols, procedures, responsibilities, and minimum requirements to operate, repair, maintain and replace the Utility System in accordance with these Performance Standards and the Concession Agreement and Prudent Industry Practices. If the University provides comments on the Operations Plan that are necessary for such Operations Plan to comply with the Concession Agreement and these Performance Standards, then the Concessionaire shall implement such comments or provide some reasonable alternative that addresses the failure to comply with the Concession Agreement or the Performance Standards. The Concessionaire shall provide a list of goals for the Fiscal Year as part of the Operations Plan to indicate focus areas aligned with the above. The Operations Plan shall also include the Concessionaire's standard operating procedures for each Utility Facility in connection with its operation of the Utility System.
- e) As part of the Operations Plan, the Concessionaire shall include a maintenance management program for the Utility System. The maintenance management program shall, at a minimum, meet Prudent Industry Practices and shall include procedures and records for asset management that include critical equipment capacity identification/documentation, inspection and testing plans, PM and PdM (each as defined herein), maintenance workflow including work prioritization based on equipment criticality, planned outages, continuous improvement teams, and records management. Generally, the asset management program will be implemented in the FAMIS system for the Utility System or utilize a maintenance management system of its own choosing if the cost of such system is Approved by the University as part of the Five-Year Plan. The Concessionaire shall indicate any major changes to the maintenance workflow in the prior Fiscal Year

as well as planned improvements and/or changes aligned with provided goals in the Operations Plan.

- f) The Concessionaire shall maintain records related to its maintenance and operation of the Utility System in accordance with Section 3.12 of the Concession Agreement. The records regarding maintenance of the Utility System required to be retained by the Concessionaire shall include the following:
- i. Status of Utility System Assets with disposition of breakdowns, deteriorating conditions, failure to start, significant decrease in capacity or performance (> 5%);
 - ii. Total maintenance spend for the Fiscal Year for the repair costs and labor hours for each individual Utility and the individual work orders associated therewith;
 - iii. Usage of each Supply by commodity and Supply spend corresponding to each commodity, reported monthly compared to the expected usage and spend for the current Fiscal Year in the current Five-Year Plan and including a reasonably detailed explanation for any variation therefrom;
 - iv. Any changes to the Utility System or Utility System Operations required or made due to environmental and regulatory changes required by Law or applicable Governmental Agency;
 - v. One, three and six-year projection of life expectancies of equipment that would be considered Capital Improvements based upon maintenance performed and manufacturer's recommendations;
 - vi. State of Idaho Certificate(s) and risk management for boilers;
 - vii. Annual building inspections required by the Division of Building Safety and State of Idaho Division of Administration;
 - viii. Annual inspections required by the University Environmental Health and Safety Department or its successor department ("EHS") and documentation evidencing compliance with all applicable health and safety regulations; and
 - ix. The Preventive Maintenance (as defined herein) data specified in Section II 1(k) of these Performance Standards.
- g) The Concessionaire shall include in its Operations Plan a proposed plan for its expenditures to extend the useful life of any and all components of the Utility System, including planned replacements or any additions thereto. The proposed plan shall include any major system or specific equipment improvements planned

for the next Fiscal Year, as well as indicate changes to existing environmental permitting requirements that may be needed to implement the improvements.

- h) Currently, maintenance activities are managed through FAMIS (by Asset Works). The Concessionaire shall either continue to use the FAMIS system for the Utility System and for any requests made pursuant to ~~Section~~Part II, Section 1(k) ~~of these Performance Standards~~hereof by the University or utilize a maintenance management system of its own choosing if the cost of such system is Approved by the University as part of the Five-Year Plan (a “CMMS”). To the extent requested by the University, the Concessionaire will provide a list of system components for prioritized funding through the Idaho State Permanent Building Fund.
- i) Maintenance Workflow.
- i. The Concessionaire shall use the existing, or propose a new (depending on availability of University and Concessionaire resources), maintenance workflow process to identify, prioritize, approve, execute, and document completion for all work. The maintenance workflow process shall align with the process for the Five-Year Plan.
 - ii. The Concessionaire shall maintain an asset list with documented criticality in the CMMS.
 - iii. The Concessionaire shall train all personnel on utilization of the maintenance workflow described herein including work order generation, backlog reviews, work prioritization, outage management, schedule development, and work completion. The following defines the type of work orders:
 1. “Corrective Maintenance” is defined as the specific maintenance actions performed on Utility System Assets or Utility Facilities (or a portion thereof), in the event that a Utility System Asset’s or a Utility Facility’s current condition is below the required standards as identified by a Preventive Maintenance, Predictive Maintenance (as defined herein), or technician observation. The Concessionaire shall provide the Corrective Maintenance necessary to maintain the Utility System in good condition and repair and otherwise in accordance with Prudent Industry Practices.
 2. “Emergency Maintenance” is defined as the maintenance necessary to restore operation to equipment, systems, or components in the Utility System that have failed to operate as required.
 - iv. The Concessionaire shall perform all Emergency Maintenance as promptly as possible within time limits agreed to by the Parties and if

applicable, adhere to the Unplanned Outage (as defined herein) requirements set forth herein.

- v. The Concessionaire shall develop or maintain Preventive Maintenance and Predictive Maintenance plans based on equipment criticality, in accordance with Prudent Industry Practices, including applicable operations and maintenance best practices industry manuals and shall include those plans in the Operations Plan.
 - 1. “Preventive Maintenance” or “PM” is defined as maintenance and/or inspections on a Utility System Asset or a Utility Facility or a portion thereof based on a pre-determined schedule or run time to reduce the probability of failure. A Corrective Maintenance work order shall be written to address any findings from a Preventive Maintenance task.
 - 2. “Predictive Maintenance” or “PdM” is defined as the tests performed on a Utility System Asset or a Utility Facility or a portion thereof to determine current condition and remaining life to reduce the probability of failure. A Corrective Maintenance work order shall be written to address any findings from a Predictive Maintenance task.
- vi. The Concessionaire shall perform PM and PdM in accordance with the plans included in the Operations Plan. The Concessionaire shall keep records and track PM and PdM completion against planned schedules. The Concessionaire shall develop a process for the Concessionaire to internally approve any delay of any PM and PdM plans for a Fiscal Year as soon as reasonably practicable after execution of the Concession Agreement and shall include a plan to address operational risks. The process for approving any such delay, the approval of any such delay and the results of each such test shall be recorded in accordance with the Record Retention Policy. The Concessionaire shall promptly provide the University with Notice of any critical equipment PM and PdM plans that are incomplete in accordance with the terms of such plans.
- j) In order to properly assist the University in the comprehensive planning for, efficient management of, effective repair of, and controlled access to, the public ways on the University Campus and to lessen the public inconvenience of uncoordinated work in the Public Way while promoting the general public health, safety, and welfare, the Concessionaire shall adhere to any University or municipality policies, including the Safety, Health and Environmental Policies attached as Appendix U (collectively, the “EHS Policies”), provided that, with respect to other University policies, the University has provided the Concessionaire with written notice thereof.

- k) Upon request of the University, the Concessionaire shall perform such services for which the Concessionaire has a Concessionaire Charge Rate as requested by the University that are outside of the Utility Services and the Utility System Operations, in which case the University shall pay to the Concessionaire the cost therefor by payment of the applicable Concessionaire Charge Rate within 30 Days after receipt of an invoice therefor.
- l) The Concessionaire shall cause the Utility System to consume Supplies in a manner consistent with the Approved Five-Year Plan, and the University may direct the Concessionaire to consume Supplies in a particular manner upon Notice to the Concessionaire provided that if such direction (i) is materially inconsistent with the Approved Five-Year Plan, (ii) materially and adversely affects Utility System Operations (including the Concessionaire's ability to comply with Prudent Industry Practices or its other obligations under the Concession Agreement) or (iii) causes the Concessionaire to incur materially more Capped O&M Costs, which could not be reasonably avoided, then such direction shall be considered a University Directive if the Concessionaire provides the University with notice as soon as reasonably practicable after receipt of the University's direction.

2) **Exterior Appearance of Utility Facilities**

- a) The Concessionaire shall maintain the exterior appearance of Utility Facilities in accordance with the University's design standards applicable to the University of Idaho, provided in Appendix F, as may be updated from time to time (the "Design Standards"). Changes to the exterior appearances of Utility Facilities, including but not limited to the color and lighting of such Utility Facilities and any signage thereon, shall require prior Approval of the University.

3) **Utility Marking, GIS Mapping and Asset Management**

- a) The Concessionaire shall provide utility marking of the Utility System in accordance with applicable Law and Prudent Industry Practices. The utility marking process shall include:
- i. Support design activities during project planning and development;
 - ii. Provide pre-excavation marking for all construction and maintenance projects with 48-hours of notification;
 - iii. Provide line locating and elevation during installation of new equipment; and
 - iv. Contact "Idaho Dig Line (811)" for marking of buried Utility System distribution assets before commencing digging activity.
- b) The Concessionaire shall provide mapping updates to reflect modifications to the existing Geographic Information System ("GIS") for the Utility System including

mapping of all Utility System Assets that are abandoned and not removed during the Term. Such information and updates shall be provided in a format and include details as requested by the University.

- i. The Concessionaire shall reasonably cooperate with the University in connection with the GIS, which contains information regarding both Utility Facilities as well as other facilities which are not part of the Utility System, in connection with any changes, updates or modifications to the Utility System.
 - c) The Concessionaire shall be responsible for providing updates for the GIS to the University in a timely manner to accurately depict the state of the existing Utility System. Within 10 Business Days after any change to the state of the existing Utility System, the Concessionaire shall provide to the University the information necessary for the University to update the GIS for the Utility System due to any material change including addition, modification, repair, or abandonment of any portion of the Utility System. For purposes of providing updates for changes to the Utility System due to construction activities, a “change” shall be deemed to occur when the improvement being constructed is deemed “substantially complete” and or becomes actively employed in delivering Utility Services.
 - d) The Concessionaire shall provide regular mapping update information to the University’s team for the Utility System GIS (as designated by the University to the Concessionaire), to include surface feature updates and repairs and non-material changes, every 6 months.
- 4) **Health and Safety**
- a) The Concessionaire shall develop and adhere to safety and security standards in performing Utility System Operations which standards, at a minimum, meet Prudent Industry Practices, applicable Law and EHS Policies. The Concessionaire shall develop and document policies and procedures to ensure the security and safety of the Utility System that, at a minimum, shall be consistent with Prudent Industry Practices and current emergency management policies or procedures provided in Appendix C (the “Facilities Emergency Management Plan”) (See also Part II, Section 5(a) hereof). Such policies and procedures shall be included or referenced in the Operations Plan.
 - i. In addition, the electrical safety program shall be in compliance with all applicable Laws, including standards established by the United States Occupational Safety and Health Administration (“OSHA”) as well as the National Fire Protection Association (“NFPA”) (NFPA 70E), including applicable training and qualifications programs.
 - b) The Concessionaire shall maintain the security of the Tunnels in compliance with the requirements listed in Appendix V and shall comply with the confined space access protocols included as part of Appendix V. In addition, the Concessionaire

shall coordinate with the University's Department of Public Safety and local law enforcement, as appropriate. Where Tunnel access occurs through a University building, management of security must be coordinated with the University by calling the Facilities Maintenance Front Desk number which is currently (208) 885-6246 and this may be updated by notice from the University to the Concessionaire (the "University Front Desk Number") and reasonably coordinating with the University following such phone call.

- c) The Concessionaire shall secure the industrial control systems within the Utility System in accordance with Prudent Industry Practices and University policy then in effect.
- d) The Concessionaire shall promptly notify the University's Department of Public Safety and local law enforcement upon learning of suspected or alleged criminal activity concerning the Utility System.
- e) The Concessionaire shall abide by all regulations of the University's Department of Public Safety.
- f) The University's Department of Public Safety and EHS shall have access at all times (24 hours a day, 7 days a week) to all plants, buildings and any other Utility Facilities on the University Campus which are required to be maintained by the Concessionaire.
- g) The Concessionaire shall be responsible for ensuring that safety security alarms, including fire alarms which are part of the Utility System, are directly tied to the life and safety systems of the University.
- h) Except as otherwise provided in Concession Agreement, Concessionaire shall ensure that any and all cameras installed by Concessionaire in Utility Facilities shall provide a direct feed to the University's security office, use the University's network and meet the University's specifications for video surveillance as described in Appendix A.
- i) The University of Idaho facilities are under the jurisdiction of the State Fire Marshall. Therefore, all Utility Facilities on the University Campus shall be subject to inspection by the State Fire Marshall, Environmental Health and Safety personnel, University Fire Protection personnel and the Department of Public Safety.
- j) The Concessionaire shall adhere to any and all applicable policies, practices and procedures set forth by the University, including the EHS Policies.
- k) As part of the Concessionaire's obligation to comply with all Laws, the Concessionaire shall comply with all OSHA requirements including but not limited to, documented safety training programs and injury reporting and logs.

- l) The Concessionaire and the Operator are required to maintain commercial and appropriate drug testing in accordance with all applicable Laws, including the requirements of the US Department of Transportation.

5) **Emergency Response and Unplanned Outages**

- a) The Concessionaire shall follow the current Facilities Emergency Management Plan in the event of an Emergency or other event described therein.
- b) The Concessionaire shall provide personnel to support all procedures and activities required by the University during an Emergency and/or failure of the Utility System or any portion thereof which failure had not previously been approved by the University (each, an “Unplanned Outage”), as described in more detail for each Utility as set forth in Parts III through XI hereof, in order to provide the required Utility Services.
- c) During an Unplanned Outage, the Concessionaire shall work cooperatively with the University until Utility Services are restored. During any Unplanned Outage, the Concessionaire shall follow all communication procedures for an Emergency and all applicable Emergency response plans provided by the University, including working with a representative contact designated by the Assistant Vice President for Facilities (the “Communications Contact”). The Concessionaire shall provide status updates as soon as possible after any Emergency or Unplanned Outage to the Facilities Maintenance Front Desk to any designated University contacts using the communication medium designated by the University.
- d) The Concessionaire shall adhere to the procedures and requirements for an Unplanned Outage set forth in these Performance Standards for each individual component of the Utility System.
- e) The Concessionaire shall designate a representative to participate in the University’s Critical Incident Management Team (the “CIMT”), which representative shall:
 - i. Attend meetings at the reasonable request of the University;
 - ii. Obtain training required by the University; and
 - iii. Assist in coordination with the University to respond during Emergencies.
- f) The Concessionaire shall adhere to the following priority list for restoration of the Utility System following an Unplanned Outage, whereby the Concessionaire shall cause buildings that contain in whole or in part the following functions to be tended to in this order of priority: (1) central public works utilities; (2) health, life and safety; (3) process cooling and heating loads; (4) laboratory; (5) research; (6) agricultural buildings; (7) administrative; and (8) out buildings serving cold storage. The foregoing priority list may be updated by the

University at any time upon written notice to the Concessionaire. Any such update shall not be considered a modification to these Performance Standards subject to Section 6.3 of the Concession Agreement.

- g) During any Unplanned Outage, the Concessionaire shall send prompt updates to the CIMT and the designated Communications Contact, if activated, in addition to the procedures and requirements for an Unplanned Outage set forth in these Performance Standards for each individual component of the Utility System.
- h) At least 48 hours before (i) any visit by a head of state or political dignitary, (ii) any significant political event, (iii) any home football game, (iv) move-in week for fall semester on the University Campus, (v) finals week for fall semester and spring semester for the University Campus (the exact dates of which shall be available on the University's website), (vi) graduation ceremonies or (vii) any other event which the University provides advance written notice of to the Concessionaire (each, a "Major Event"), the Concessionaire shall:
- i. ~~Prepare~~prepare a response plan for an Unplanned Outage, in accordance with the University's then-existing mechanical and Electric System access and response practices and the Facilities Emergency Management Plan and promptly implement such plan as necessary; and
 - ii. ~~Provide~~provide a subject matter expert as a resource to the University's Strategic Communications Department and the CIMT before and during such Major Event.
- i) If the Concessionaire is not provided with advance notice of a Major Event sufficient to comply with the deadline set forth in Part II, Section 5(h)-, above, the Concessionaire shall provide the listed information as soon as practicable following notification of any Major Event. If a Major Event recurs during a Fiscal Year, e.g., home football games, then the Concessionaire's responsibility shall be to provide such response plans and the subject matter expert for those Major Events, as a group, and the Concessionaire shall not be responsible for submitting separate information for each such Major Event within that group, unless the University so requests.
- j) In the event an Unplanned Outage impacts the University Campus, the Concessionaire shall, at the University's request, provide a subject matter expert as a resource to the University's Strategic Communications Department for the duration of the need arising from the Unplanned Outage.
- k) Promptly following any Unplanned Outage, and in any event within 15 Business Days thereafter, the Concessionaire shall provide to the University a report on such Unplanned Outage, which shall include a reasonably detailed summary of the Unplanned Outage, including the apparent cause, and the corrective actions taken with respect thereto. As soon as reasonably practical thereafter, but in any event within 60 Days after the Unplanned Outage, the Concessionaire shall

provide the University with a root cause analysis of the Unplanned Outage and any recommended changes in operations or Capital Improvements that the Concessionaire recommends to prevent future, similar Unplanned Outages.

- l) The Concessionaire shall notify the Facilities Maintenance Front Desk as soon as reasonably practicable by calling the University Front Desk Number in the event of an Unplanned Outage.

6) **Procedures for Planned Outages**

- a) The Concessionaire shall develop and follow plans and procedures for communicating a planned outage of the Utility System (a “Planned Outage”) in a form and manner reasonably acceptable to the University. Failure to adhere to such requirements shall cause any outage of any part of the Utility System to be deemed an Unplanned Outage. In addition to the requirements set forth above, the Concessionaire shall provide notice of such Planned Outage at least 10 Business Days before the Planned Outage.
- b) Prior to a Planned Outage, the Concessionaire shall consult with the University to determine when temporary utility sources (such as electrical generators, boilers or chillers) are necessary to maintain building operations, and the Concessionaire shall provide such temporary utility sources as agreed with the University.
- c) The Concessionaire shall coordinate the restoration of Utility Services following a Planned Outage with the University.

7) **Design Standards**

- a) The Concessionaire shall follow the Design Standards for all portions of the Utility System, unless (i) otherwise provided for herein, (ii) the Utility System does not, as of the Closing Date, comply with the Design Standards and then only with respect to such non-compliance, or (iii) Approved by the University, provided that the University shall be reasonable in granting its Approval to a deviation from the Design Standards that is consistent with other deviations to the Design Standards then-existing with respect to the Utility System. The Concessionaire shall develop and document design standards for the Utility System or deviations from the existing Design Standards and shall submit them for Approval to the University within 1 Year after the Closing Date. The University shall review such proposal and respond, either approving or disapproving such submission within 60 Days after receipt thereof. If the University so disapproves, it shall provide a reasonably detailed explanation as to the reasons therefor, and the Concessionaire shall resubmit a revised submission addressing such reasons. Once such submission (or re-submission) is Approved by the University, it shall be included in the Design Standards and apply to the Utility System. Future changes to those Design Standards for the Utility System shall be Approved by the University before adoption.

- b) The University retains the right to modify or update the Design Standards or (to the extent that such Design Standards relate to the Utility System) direct the Concessionaire to do so, which modification or update shall be deemed a modification of these Performance Standards under Section 6.3(a) of the Concession Agreement. The Concessionaire shall participate in and provide input on periodic updates to the Design Standards and shall provide proposed changes if requested by the University.

8) **Material and Equipment Management**

- a) The Concessionaire shall procure all necessary equipment and materials to properly operate the Utility System. Such equipment and material shall be appropriate for its use and, at a minimum, meet Prudent Industry Practices.
- b) The Concessionaire shall include in its Operations Plan its plan for materials management; which shall include:
- i. ~~A~~a process for procuring materials for the operation of the Utility System;
 - ii. ~~A~~a process for maintaining adequate inventory levels to account for Planned Outages and Unplanned Outages;
 - iii. ~~A~~a plan for maintenance of Concessionaire's storage facilities;
 - iv. ~~A~~a method for staging materials; and
 - v. ~~Minimum~~minimum levels of certain materials identified as critical by the Concessionaire, below which the Concessionaire shall reorder such materials.
- c) In all events, the Concessionaire shall purchase materials and equipment for use in the Utility System that are:
- i. ~~F~~it and serviceable for the intended purpose and free of defects;
 - ii. UL-listed, if applicable at the time of purchase; and
 - iii. ~~O~~f the type and quality typically used in Comparable Utility Systems.

9) **Personnel, Operations and Reporting**

- a) Whenever the Concessionaire is required to utilize a qualified engineer, such engineer shall be subject to the University's prior Approval. The Concessionaire shall have the right to provide a list of qualified engineers to the University on an annual basis for the University's approval in accordance with Idaho Code. The Concessionaire shall then be permitted to utilize any engineer on such list.

- b) As part of its Operations Plan, the Concessionaire shall provide a high-level staffing plan, which shall include, at a minimum:
- i. ~~Organizational~~organizational chart(s);
 - ii. ~~Any~~any changes to shift planning for normal operations;
 - iii. ~~Emergency~~emergency response staffing and communications contact who is designated to work with the University (the “Concessionaire Communications Contact”);
 - iv. ~~New~~new position descriptions;
 - v. ~~Screenings~~screenings / testing, which the Concessionaire shall provide to the University promptly after receipt thereof;
 - vi. ~~High-level~~high-level training and employee development plan;
 - vii. ~~Employee~~employee credentials, licenses and other certifications;
 - viii. ~~Diversity~~diversity and inclusion;
 - ix. ~~Rates~~rates of pay;
 - x. ~~Overtime~~overtime policies and practices for all employees; and
 - xi. ~~One~~one year and five-year plans for staffing level increases or decreases, including organizational charts indicating the areas of staff addition or reduction.
- c) As part of its Operations Plan, the Concessionaire shall include a plan for providing personnel coverage during an Emergency, for both a short-term and long-term closure of the University. Such plan shall include a list of employees designated as serving in “essential,” “alternate,” or “standby” status during an Emergency, and identify the Concessionaire Communications Contact, for both short-term and long-term closures. The Concessionaire’s Emergency staffing and designations shall conform with then-current University policies for Emergency preparedness and for short-term and long-term closures.
- d) ~~Within 10 days after~~By the end of ~~each~~the following month, the Concessionaire shall provide the Utility System operating efficiency metrics as outlined in Appendix G. The Concessionaire shall cause the Utility System to be within 10% of the operating efficiency metrics outlined in Appendix G. If, in any month, the operating efficiency metrics are not within 10% of Appendix G, the Concessionaire shall promptly provide the University notice and shall cooperate in good faith with the University on the means to cause the operating efficiency metrics to be within 10% of Appendix G as soon as reasonably practicable.

- e) Unless information is required earlier for meeting required compliance reporting and the University has provided the Concessionaire with prior notice thereof, within 60 Days after the end of a Fiscal Year, the Concessionaire shall provide information to the University regarding the operations of the Utility System, including:
- i. ~~Supply~~supply mix and average cost of each Supply over the past Fiscal Year;
 - ii. ~~The~~the results of the chemical, water treatment, and pre-treatment plans;
 - iii. ~~Environmental~~environmental and regulatory compliance;
 - iv. ~~The~~the implementation of safety programs;
 - v. ~~The~~the effectiveness of utility data systems and IT network security;
 - vi. ~~Plant~~plant operating procedures;
 - vii. ~~Peak~~peak Utility System loads and percentage of installed capacity; and
 - viii. Utility System operating efficiency metrics as outlined in Appendix G.
- f) The Concessionaire shall support project design reviews with the University Architectural and Engineering Services for University Campus projects requiring utility services support and new utility connection planning, design and construction inspections.
- g) The Concessionaire shall plan and execute hot work and energized electrical equipment testing with respect to the Electric System per applicable safety standards including NFPA 70E.
- h) The Concessionaire shall develop and conduct electrical power system studies ~~including load demand, short circuit, electrical coordination, and OSHA arc flash utilizing SKM software (or equivalent) and~~ in compliance with all applicable Institute of Electrical and Electronics Engineers (“IEEE”) standards, ~~which~~and such studies shall be conducted on a 5-year cycle with an annual review of deferred maintenance projects. The Concessionaire will maintain University Campus SKM (or equivalent) arc flash modeling, incorporating facility and building studies as they are conducted and made available by the University. The Concessionaire will provide utility point of interconnection fault current data to the University promptly after receipt of written notice from the University.
- i) The Concessionaire shall maintain Pipe-Flo and load models at or above the level existing as of the Closing Date or develop mutually acceptable alternative models for the steam portion of the Steam and Condensate System that is designed for pressures of at least 120 psi and the Chilled Water System.

- j) The Concessionaire shall comply with the Utility Service Connection and Inspection Standards provided in the Design Standards.

10) **Environmental Compliance**

- a) In operating the Utility System, the Concessionaire shall comply with applicable Environmental Laws, all Authorizations related thereto (including all Campus-Wide Permits), EHS Policies, and any and all environmental or sustainability standards, policies or procedures adopted by the University and communicated to the Concessionaire.
- b) The Concessionaire shall instruct its employees and employees of the Operator to conduct all operation, repair, maintenance and replacement work in a manner so as to minimize exposure to Hazardous Substances. The Concessionaire shall notify the University of any planned activity that may disturb building materials containing Hazardous Substances and may require special handling pursuant to applicable Environmental Laws. If advance notice is not practicable, the Concessionaire shall notify the Facilities Maintenance Front Desk as soon as reasonably practicable by calling the University Front Desk Number after encountering building materials containing Hazardous Substances on or in the vicinity of the Utility System, and shall immediately cease any activity which would disturb or further disturb hazardous building materials until after Concessionaire has notified and consulted with the University regarding proper handling of such material. If the Concessionaire, in the course of its operation, repair, maintenance or replacement activities, creates a hazardous condition by disturbing or otherwise altering building materials containing Hazardous Substances, the Concessionaire shall manage such Hazardous Substances in accordance with all applicable Environmental Laws and in compliance with all University policies and programs including the EHS Policies and the Asbestos Management Program set forth in Appendix D.
- c) If the Concessionaire encounters or disturbs any Hazardous Substances in the course of its operations for which the University has retained liability pursuant to Section 3.2(d) of the Concession Agreement, the Concessionaire shall notify the University in writing and shall also contact the Facilities Maintenance Front Desk and shall work with the University to facilitate any University action deemed necessary to comply with applicable Environmental Laws. In any case, Concessionaire shall take measures to avoid causing, exacerbating, or contributing to any hazardous condition or any Release of a Hazardous Material encountered in the course of its operations. Further, whenever the Concessionaire becomes aware of any Release of any quantity of a Hazardous Substance, the Concessionaire must comply with the notice requirements set forth in Section 8.1(b) of the Concession Agreement.
- d) The Concessionaire shall be responsible for managing and remediating Hazardous Substances Released or encountered in the course of operations of the Utility System, including those in the Storm Water System, in accordance with all

applicable Environmental Laws but only to the extent specified in Section 8.1(b) of the Concession Agreement (and, for the avoidance of doubt, to the extent that such liabilities and obligations are not otherwise considered to be excluded from liabilities and obligations of the Concessionaire pursuant to Section 3.2(d) of the Concession Agreement). The Concessionaire shall notify and coordinate with EHS before taking any non-emergency action to address a Release of a Hazardous Substance and shall include the University in any correspondence with regulatory officials regarding the management and remediation of the Hazardous Substances. If the University becomes aware of any Release or presence of Hazardous Substances in the Storm Water System, it shall promptly notify the Concessionaire, and the Concessionaire shall remediate such Hazardous Materials in accordance herewith.

- e) In addition to the obligations set forth in Section 11.13 of the Concession Agreement pertaining to the Campus-Wide Permits, the Concessionaire shall be responsible for coordinating with EHS for the completion of and filing all environmental reports and for environmental recordkeeping and monitoring pertaining to the operation of the Utility System as required by the University or as may be required under applicable Environmental Laws. In connection therewith, the Concessionaire shall promptly provide a copy of any report or communication submitted to a Governmental Authority by the Concessionaire or the Operator with respect to the Utility System related to Hazardous Substances or Environmental Laws.
- f) As part of its obligations under Section 3.12(a) of the Concession Agreement, the Concessionaire shall provide all necessary related operational and environmental data to the University for inclusion in campus-wide regulatory environmental reports and required records.
- g) The Concessionaire shall coordinate with the University, including EHS, regarding the development and implementation of the following plans/programs as required by applicable Environmental Laws:
 - i. Spill Prevention Control, and Countermeasure Plan (“SPCC Plan”);
 - ii. ~~Storm~~storm water management plan which complies with applicable National Pollutant Discharge Elimination System rules and University requirements, including the University’s Municipal Separate Storm Sewer System (MS4) permit;
 - iii. ~~Petroleum~~petroleum storage and tank management program including inspections; and
 - iv. ~~Refrigerant~~refrigerant leak monitoring, reporting, and corrective action.
- h) The Concessionaire must certify annual compliance to the University by certifying at least to the following on September 30 of each year:

- i. Certified recovery or recycling machines are used prior to disposal of appliances, except for MVACs and MVAC-like appliances. Certifications of machines are maintained on-site and available for review.
 - ii. Certified recovery or recycling machines are used when maintaining, servicing, or repairing appliances, except for MVACs. Certifications of machines are maintained on-site for review.
 - iii. Certified technicians verify that the applicable level of evacuation has been reached prior to opening.
 - iv. Records are maintained on-site for review showing compliance with the less than 15 or 35 percent loss of refrigerant within a 12-month period for appliances containing more than 50 pounds of refrigerant.
 - v. Certification of training for technicians is maintained on-site for review.
 - vi. Technician certification is provided to the wholesaler when purchasing Class I or Class II refrigerants.
 - vii. Service records are kept for appliances containing more than 50 pounds of refrigerant and are maintained on-site for review.
 - viii. All records shall be maintained at the refrigeration shop and accessible for inspection by the University and Idaho Department of Environmental Quality or its successor agency (“Idaho DEQ”).
- i) Hazardous Substances
- i. The Concessionaire shall not be allowed to use, dispose, treat or store any Hazardous Substances, other than those used in its ordinary course of operations, without written consent by the University.
 - ii. The Concessionaire shall manage all wastes resulting from its operations in accordance with EHS Policies and applicable Environmental Laws. All applications, certifications and notifications required for the generation, storage and disposal of Hazardous Substances shall be provided to the University at least 10 Business Days in advance of their submission, and the Concessionaire shall, in good faith, discuss with the University any proposed changes thereto.
- j) Wastewater
- i. Industrial discharge from operation of the Utility System shall meet the requirements of all Laws, including Environmental Laws and any directives provided by Governmental Authorities.

- ii. Wastewater discharge permits and wastewater discharge operating requirements shall be coordinated with the University, and are the responsibility of the Concessionaire.
 - iii. Preapproval from the applicable Governmental Agency for any discharges from the Sanitary Sewer System to the applicable municipal sewer system shall be the responsibility of the Concessionaire.
- k) The Concessionaire shall be responsible for evaluation, recycling and/or disposing of waste generated in the course of Utility System Operations, in compliance with applicable Environmental Laws and in alignment with University policies. The Concessionaire shall collaborate in good faith with EHS in determining the foregoing.
- l) Environmental Emergency
- i. In the event that the Concessionaire has become aware of a Release of Hazardous Substances into the environment due to Utility System Operations, the Concessionaire shall immediately notify the University and the appropriate Governmental Authority in accordance with applicable Laws and applicable University policy.
 - ii. The Concessionaire shall also take immediate steps to remediate any release of Hazardous Substances and to minimize further Release of Hazardous Substances into the environment. The Concessionaire shall have the opportunity to coordinate with UI Facilities Management for pick up and disposal of recycling and municipal solid waste generated at the Concessionaire's expense and at the sole discretion of the University.
- m) Construction in Flood Plain. Concessionaire shall be responsible for obtaining (on its own behalf or on behalf of the University, as applicable) any required Flood Plain Permits from the US Army Corps of Engineers and Idaho DEQ via the Joint Application process for the Utility System (including any Capital Improvements or Material Changes) and the Utility Facilities, and shall adhere to all requirements from permits issued by those authorities. The Concessionaire shall reasonably cooperate with the University for obtaining any required Flood Plain Permits from the US Army Corps of Engineers and Idaho DEQ via the Joint Application process for property outside of the Utility System and the Utility Facilities (or involving a combination of property within and outside the Utility System and the Utility Facilities).
- n) Chemical Inventory. The Concessionaire shall be responsible for complying with the Resources Conservation and Recovery Act (RCRA) and the Emergency Planning and Community Right-to-Know Act (EPCRA) with respect to the Utility System Operations and the Utility System including all relevant chemical inventories and reporting requirements. Furthermore, the Concessionaire shall

comply with the University's Hazard Communication Program attached hereto as part of the Safety Health and Environment Policy in Appendix U.

- o) Permits to Construct. If the Concessionaire undertakes any work that requires a permit to construct application to the Idaho DEQ and/or the State Department of Health, it shall provide the University all required materials to be submitted with respect thereto, including any application fees (the cost of which are Capped O&M Costs), and the University shall have the right to review and Approve or disapprove such application within 10 Business Days. If Approved, the University shall submit such application.
- p) If in connection with any Authorizations, including the Campus-Wide Permits, any fees or charges are incurred with respect to the Utility System or the Utility System Operations, the Concessionaire shall pay such amounts to the University within 10 Business Days after request, and the cost thereof may be considered a Capped O&M Cost. With respect to the Title V Permit, the Concessionaire shall pay the annual emission inventory fees as calculated by the EHS and Idaho DEQ officials. The Concessionaire shall provide the responsible official from the University with all information pertaining to the annual emissions inventory. Notwithstanding the foregoing, to the extent that any fee, charge, penalty or other amount is payable in connection with any Authorization due to a failure to comply with a specified limit or other condition of such Authorization, the Concessionaire shall only be liable to pay a portion of such amount to the extent that its actions contributed to such failure.
- q) Underground Storage Tanks. Neither the Concessionaire nor the Operator will install any underground [fuel](#) storage tanks on the Utility System Land or anywhere on the University Campus [without the University's prior Approval.](#)
- r) Aboveground Storage Tanks. Neither the Concessionaire nor the Operator will install any aboveground storage tanks on the Utility System Land or anywhere on the University Campus without the approval of the university's Department of Environmental Health and Safety.

11) Utility Office Functions

The Concessionaire shall establish an office of the Utility System (the "Utility Office"), which shall be staffed by the Utility System Operator personnel and shall have a head of the Utility Office which shall serve as the lead of the Utility Office. The Utility Office is the primary point of contact for the University regarding information on the Utility System and Utility System Operations, including Planned Outages, Unplanned Outages, general campus information and event-specific information related to the Utility Facilities and Utility Services.

12) Interagency Cooperation and Coordination

- a) The Concessionaire is required to cooperate with any and all local, state and federal governmental, regulatory and law enforcement agencies. As part of such cooperation, the Concessionaire shall expect, and reasonably accommodate,

planned and unplanned inspections by Idaho Department of Building Safety, Idaho DEQ, Idaho State Fire Marshal and EHS.

- b) The Concessionaire's required cooperation may include, but not be limited to:
- i. ~~Providing~~providing access to the Utility Facilities;
 - ii. ~~Closing~~closing Utility Facilities for public safety purposes;
 - iii. ~~Disconnecting~~disconnecting Utility Services or a portion thereof due to an Emergency or law enforcement situation;
 - iv. ~~Providing~~providing access to information contained in any surveillance system;
 - v. ~~Attending~~attending planning and operational meetings;
 - vi. ~~Providing~~providing a representative in the CIMT in the event of a large-scale or critical situation that involves any aspect of the Utility Facilities or the Concessionaire's responsibilities; or
 - vii. ~~Any~~any other action that is deemed necessary to ensure public safety.

13) **University Department Office Cooperation**

- a) The Concessionaire will work collaboratively with departments, offices or other entities of the University for efficient, safe and effective Utility System Operations pursuant to the Concession Agreement and these Performance Standards or as may reasonably requested from time to time by the University.
- b) The Concessionaire's involvement with these departments as it relates to the Utility System may include, but not be limited to:
- i. ~~Participation~~participation in appropriate campus planning meetings including working with the University to coordinate responses to media or other inquiries;
 - ii. ~~Coordination~~coordination of information and logistical activities to ensure customer utility needs are met;
 - iii. ~~Coordination~~coordination between Concessionaire construction projects and other construction activities being conducted by the University;
 - iv. ~~Participation~~participation on work teams to plan impacts under numerous scenarios related to planned and unplanned events;
 - v. ~~Campus~~campus Emergency coordination;

- vi. ~~On~~on- and off-campus construction; and
- vii. ~~Working~~working with University stakeholders to execute plans.

14) **Public Relations and Media Interactions**

- a) The Concessionaire shall have procedures in place for working with the University and also for interacting with the University community, to the extent requested by the University. All communications about the Utility System directed to the University Campus constituents, or other University stakeholders must be coordinated with and Approved by the University. The Concessionaire shall work with the designated University Communications Contact.
- b) The Concessionaire shall work with the University administration to engage the University community and media before, during and after any material event impacting or involving the Utility System or Utility Service, which plan shall be implemented following Approval by the University.
- c) The Concessionaire may be contacted by members of the University community and media regarding information pertaining to the Utility System or Utility Service, and the Concessionaire shall, at the University's option, either provide a referral to the appropriate entity (which may include a designated University representative) or a knowledgeable individual to respond directly to the University community and media. The University reserves the right to take any and all action necessary to ensure effective communication.

15) **Vehicle Use and Operation**

The Concessionaire will be permitted to utilize service vehicles to facilitate the operations of the Utility System. The Concessionaire shall cause all of the operators of those vehicles to be trained in accordance with the Commercial Drivers Training Program attached hereto as Appendix AA. In addition, because the Concessionaire's service vehicles will also represent the image and character of the University, the following guidelines must be followed for the use of service vehicles:

- a) The Concessionaire must ensure such service vehicles are in good operating condition and must maintain a sufficient inventory of service vehicles to meet the obligations of the Concessionaire at all times.
- b) The Concessionaire shall be responsible for ensuring the safe operation of all service vehicles.
- c) Insurance must be secured and maintained in accordance with the Concession Agreement.
- d) All service vehicles utilized by the Concessionaire must be clean, safe and regularly maintained to ensure safe operation.

- e) The vehicle body must be relatively free from damage. If damage occurs, it must be repaired within a reasonable period of time.
- f) Annual safety inspections must be performed and documented.
- g) All vehicles in use must have a cumulative fleet MPG average which meets applicable Federal fuel-efficiency standards, and must otherwise comply with all Laws and applicable University sustainability standards.
- h) All service vehicles will be clearly identified and bear uniform markings on both sides of the vehicle. These include, but are not limited to:
 - i. ~~Company~~company name; and
 - ii. ~~Vehicle~~vehicle (fleet) number located on the rear of each vehicle.
- i) The Concessionaire shall develop and implement service vehicle user requirements and procedures including, but not limited to, the following:
 - i. ~~Employees~~employees must be properly trained on proper and safe use of service vehicles;
 - ii. ~~The~~the Concessionaire must provide standards and procedures for screening service vehicle drivers and maintaining driver records;
 - iii. ~~Service~~service vehicle operators shall not permit unauthorized passengers to utilize the service vehicles at any time; and
 - iv. ~~The~~the Concessionaire shall report all service vehicle accidents on University property to the University within ~~one (1)~~ Business Day following any accident.
- j) Service vehicles are subject to all University parking regulations and procedures.
- k) Service vehicles shall be licensed and authorized to use public roads.

16) **Utility Service Inquiries**

- a) The Concessionaire shall establish and implement a process for recording in the existing CMMS (whether FAMIS or its successor) any University questions and comments about Utility System Operations and Utility Services (“Service Inquiries”). Service Inquiries shall be recorded as they are received. The Concessionaire shall maintain a record of Service Inquiries which shall include:
 - i. ~~Specifies~~specific Utility Service referred to in each Service Inquiry;
 - ii. ~~Details~~details of the Service Inquiry;

- iii. ~~A~~a description of actions taken by the Concessionaire in response to the Service Inquiry, including corresponding date of actions taken; and
 - iv. ~~Details~~details of how the Service Inquiry was resolved.
- b) The database of Service Inquiries shall be provided to the University upon request.
 - c) The Concessionaire shall respond to all non-outage related Service Inquiries within ~~one (1)~~ Business Day of receipt thereof and shall resolve all Service Inquiries in a timely manner.
 - d) The Concessionaire must accept and respond to University Service Inquiries and outage reports on a 24-hour basis.

17) **Emergency Safety Plans**

- a) As part of its Operations Plan, the Concessionaire shall include a Fire Safety Plan, Evacuation Plan and Building Emergency Action Plan (collectively, “Emergency Safety Plans”) for the emergency response for Utility Facilities in the event of an Emergency that permits staff to quickly and safely evacuate each Utility Facility or take other applicable emergency measures to protect life and property. The Emergency Safety Plans must be in the same format as all other University building emergency action plans and include, in at least one of the Emergency Safety Plans, at a minimum, the following:
 - i. ~~Evacuation~~evacuation procedures and roles;
 - ii. ~~Evacuation~~evacuation routes;
 - iii. ~~Shelter-in-place~~shelter-in-place location(s);
 - iv. ~~Emergency~~emergency communications;
 - v. ~~Training~~training and drill schedules; and
 - vi. ~~Emergency~~emergency Utility Facility contact.
- b) The Emergency Safety Plans will be created in conjunction with the CM Plan, as defined below. The Emergency Safety Plans shall be submitted to the University for the University’s comment, but the University approval is not required. These plans must be evaluated on an annual basis and updated as needed. The Concessionaire shall make personnel and other resources available to conduct fire drills, Emergency drills or Emergency planning required by the University as requested.

- c) The personnel training program shall include training on all Emergency activities and procedures required by Law. Documentation of enrollment and satisfactory completion shall be supplied to the University and updated at least annually.

18) **Continuity Management Plan**

- a) As part of the Operations Plan, the Concessionaire shall include a Continuity Management Plan (“CM Plan”) to establish procedures and protocols in relation to continuing or recovering services following an Emergency. This CM Plan must include, at a minimum, the following:
- i. ~~Plan~~plan overview, scope, and assumptions document;
 - ii. ~~Response~~response teams with named individuals assigned to each team;
 - iii. ~~An~~an initial call tree;
 - iv. ~~Contact~~contact information for key team members, vendors, departments, agencies, and university stakeholders;
 - v. ~~Initial~~initial response activities in the following categories: command/leadership, communications, HR/employee care, financials, IT, and assessment;
 - vi. ~~A~~a list of all Utility Services, prioritized in order of recovery, with recovery time objectives assigned to each;
 - vii. ~~One~~one named individual as the contact in charge of recovery and one as an alternate contact for each service;
 - viii. ~~A~~a description of how each service will be continued or recovered in each of the following three scenarios:
 1. ~~Unavailability~~unavailability of majority of staff;
 2. ~~Unavailability~~unavailability of key applications and/or equipment; and
 3. ~~Unavailability~~unavailability of the building/Utility Facility; and
 - ix. ~~List~~list of minimally-required resources for recovery;
- b) This CM Plan will be created in conjunction with the Emergency Safety Plans. The Concessionaire must evaluate the CM Plan on at least an annual basis and update the CM Plan as needed.

19) **Information Technology, Communications and Connectivity**

- a) The Concessionaire shall work with the ~~Division~~Office of Information Technology, ~~Information Technology Services (“ITS (“OIT”)~~ to develop and implement appropriate interconnection protocols and security measures whenever the Concessionaire is connecting to any electronic network, communications system or other electronic media owned, operated or managed by the University or its agents. The Concessionaire shall provide annually, as part of the Operations Plan, a plan to keep network components updated with a replacement plan for any outdated equipment. If network equipment maintained by the Concessionaire ages to the point that it no longer will take updates in security, operating system, or process software provided by the developer of such equipment, then the equipment shall be replaced by the Concessionaire within six (6) months after such point where appropriate.
- b) The Concessionaire understands that the University network is not certified for life-safety levels of availability that the University network will not be available during planned or unplanned maintenance events and that repairs on peripheral portions of the University network are handled on a commercially reasonable efforts basis.
- c) Prior to connecting to or using the University’s electronic network, communications system or other electronic media, Concessionaire shall submit to the ~~ITS~~OIT for review, and approval all of Concessionaire’s electronic network security protocols, application security protocols, data storage protocols, access management procedures, and any other information that ~~ITS~~OIT determines necessary to protect the integrity and security of the University’s electronic systems and communications networks.
- d) Any use of the University’s electronic network, networking equipment, network closets, fiber infrastructure, copper infrastructure or other information systems shall be done with the approval of ~~ITS~~OIT and in compliance with current ~~ITS~~OIT policies and standards, ~~attached hereto as Appendix X and Appendix Y.~~
- ~~e) Concessionaire understands that the University cannot share network equipment (including but not limited to switches, routers and firewalls) nor infrastructure services (including but not limited to DHCP, DNS, IPAM, AAA services and network access control).~~
- ~~f) Concessionaire hereby designates the following individuals: [_____]~~will provide name and contact information of designees to respond in a timely fashion to any and all security incidents, including copyright complaints, on connectivity provided through University-provided IP addresses.

⁺~~NTD: Concessionaire to provide.~~

- gf)** The University shall, except as set forth herein, retain responsibility for installing and maintaining the University's fiber network; provided, the Concessionaire shall be responsible for (i) protecting and maintaining such fiber network in accordance with its obligations to maintain the Tunnels set forth in Part II, Section 4(b) hereof and (ii) the Concessionaire shall be responsible for maintaining the portion of the University's fiber network that is exclusive and unique to the Utility System, to which the University hereby grants the Concessionaire a license to access, operate and maintain, and shall have the right to modify or add on to such portion of the University's fiber network with the University's Approval. The Concessionaire may lease fiber(s) or wired communications from the University, subject to agreement by the University, and shall have a non-exclusive right to use portions of the University's fiber network that had been used in Utility System Operations on a non-exclusive basis with other operations of the University prior to the Closing Date. Any costs charged by the University for communications equipment may be included as O&M Costs or Capital Improvement costs pursuant to the terms of the Concession Agreement. The University shall provide such optical fiber and/or wired communications to the Concessionaire at the cost normally charged by HFSOIT to internal University customers, if available, or at the then-current average market rate charged by local providers of materially similar services.
- hg)** Any networks installed and maintained by Concessionaire as part of the Utility System must be built according to industry best practices including NERC CIP or other then-current standards as Approved by the University.
- ih)** Subject to the terms of the Concession Agreement and except as caused by the University's negligence or willful misconduct, Concessionaire assumes all risk and agrees to indemnify, defend and hold harmless the University from any and all actions, claims, costs, demands, or suits arising out of or resulting from the Concessionaire's connection to or use of any electronic network, communications system or other electronic media owned, operated or managed by the University or its agents.
- ji)** Prior to deploying or using any wireless communications within the geographic boundaries of the University, Concessionaire shall submit to HFSOIT for review, approval and acceptance, a detailed description of Concessionaire's proposed wireless communications technology and any other information that HFSOIT determines necessary. If required by HFSOIT, the Concessionaire will implement all reasonable measures necessary (including abatement) to protect the integrity and security of current wireless communications networks and other equipment operating at the University.
- kj)** ~~Conditions and requirements for~~The Concessionaire's use ~~for all~~of the University's wired network (IP), dark fiber, cellular data, analog telephone, or 802.11 WiFi communications systems ~~on the University Campus, including~~shall be by the University's Approval only. The Concessionaire shall adhere to all

service-level agreements, security protocols and operating standards ~~for such use are set forth in Appendix X.~~

- k) [The line of demarcation for the Utility Network \(as defined in Appendix BB\) and certain roles and responsibilities of the University and the Concessionaire related to the Utility Network and information technology are set forth in Appendix BB.](#)

20) **Ongoing Utility System Projects – Cogeneration Plant**

Within 180 Days after completion of the cogeneration plant identified as part of the Ongoing Utility System Projects, the University shall have the right to update these Performance Standards to provide reasonable additional requirements for the operation and maintenance of such cogeneration plant and to make reasonable changes to any of the existing requirements to accommodate such cogeneration plant. The Concessionaire shall reasonably cooperate with the University in developing such additional requirements and changes. Upon delivery of such update, the Performance Standards shall be deemed modified, and the University shall not owe the Concessionaire any Concession Compensation in connection therewith. Prior to the update of the Performance Standards described herein, the Concessionaire shall operate the cogeneration plant in accordance with the Concession Agreement and Prudent Industry Practices.

Part III - PERFORMANCE STANDARDS – CHILLED WATER SYSTEM

1) Temperature Requirements

- a) The Concessionaire shall ensure that the supply temperature of all chilled water being supplied by the portion of the Chilled Water System within the Energy Plant, the South Campus Chiller Plant, and the McClure Hall Space on the University Campus must be between 42 and 46 degrees. The return ~~temperatures-~~ must temperature is targeted to be between 57 and 65 degrees.
- b) The monitoring points to determine compliance with such requirements are set forth on Appendix O.

2) Pressure Requirements

- a) The Concessionaire shall ~~ensure that the water being distributed by the Chilled Water System maintains pressure as required to maintain building chilled water interface valves in a general range between 20% and 90% open for normal operations that allows for flow control (provided that for any building on the University Campus that operates directly from Chilled Water System pressure, building chilled water interface valves may be up to 100% open).~~ maintain a minimum differential pressure (defined as the difference between supply and return pressures) of 10 psi at the Albertson’s building, or such other point as agreed by the University and the Concessionaire in writing (the “Chilled Water Pressure Measurement Point”). The differential pressure figure may be adjusted if agreed by the University and the Concessionaire acting reasonably, if supported by an accurate Chilled Water System hydraulic model prepared in accordance with Part III, Section 6 below.
- b) ~~The Concessionaire shall maintain a minimum differential pressure that is measured at the Albertson’s building must be maintained at a 14 psi differential (pressure difference between supply and return).—~~
- eb) The monitoring points to determine compliance with such requirements are set forth on Appendix O.

3) Line of Demarcation between Concessionaire and University

- a) Except as otherwise described herein, the line of demarcation for the Chilled Water System is depicted in Appendix L-3. Appendix L-3 serves as a representative diagram of the Chilled Water System. See also Appendix K-3 for a map of the Chilled Water System.
 - i. All chilled water plants, to include North Campus Chiller Plant, South Campus Chiller Plant, and McClure Plant, ~~and~~ all distribution equipment up to the isolation valve for the applicable campus building ~~envelopes-~~ ~~interface control valves, interface meters and interface programmable-~~ ~~logic controllers (“PLCs”), and meters~~ shall be considered part of the

Chilled Water System; ~~and~~. If an isolation valve is not present at a building, the line of demarcation will be immediately after the first building interface control valve.

- ii. Any building/secondary pump, building piping, heat exchange equipment ~~and~~, valves, and controls downstream of the ~~interface equipment~~ isolation valve contained within the building envelopes (or if there is no such isolation valve, then at the point immediately before the first building interface control valve) shall not be considered part of the Chilled Water System.

4) **Metering**

- a) The Concessionaire shall maintain, operate and replace Chilled Water meters in accordance with the requirements outlined herein.
 - i. The Concessionaire shall ensure the meters are accurate and calibrated to the manufacturer's recommendations.
- b) As part of the Operations Plan, the Concessionaire shall include a plan to ensure metering accuracy and a metering accountability metric for such meters that are part of the Chilled Water System. For the avoidance of doubt, the Concessionaire shall adhere to all applicable requirements with respect to meters set forth in the Design Standards attached as Appendix F.
- c) The Concessionaire shall acquire, monitor and maintain Utility consumption data within the Utility System using metering software of its choosing, subject to the Approval of such software in the Five-Year Plan by the University. In either case, the Concessionaire shall provide the University access to view and use for billing purposes the real-time meter data at any time.
- d) The Concessionaire shall ensure electronic metering occurs at a minimum of ~~60-second~~ 5-minute intervals.
- e) The Concessionaire shall maintain accurate software, monthly meter data, and provide that data to the necessary University servers for use by the University for campus billing.
- f) The Concessionaire shall collaborate with construction teams for new buildings being added to the University Campus to ensure timely installation of all metering and interface equipment at the time of connection. Additionally, appropriate start-up procedures shall be followed and monitored by the Concessionaire to ensure no impact to the Chilled Water System.

- g) Plant production meters.
- i. Production meters for the Chilled Water System must be in service when equipment is operating, functioning properly and reporting to a data system readily accessible by the University.
 - ii. Historical data starting after the Closing Date on plant production meters shall be maintained at a minimum of ~~15~~-minute intervals and readily accessible for the University's review.

Raw data shall be provided to the University in a format that cannot be edited by Concessionaire. Data will be time stamped with the date, hour (in a 24-hour format) and minute~~iii~~. Data shall be stored as required by the Record Retention Policy. Prior years' data, to the extent available, shall be maintained for the University's review. Meters shall be calibrated and maintained in accordance with the manufacturer's recommendations. The schedule for such calibration shall follow the Preventive and Predictive Maintenance Plans.

5) **Efficiency**

- a) The Concessionaire shall operate the Chilled Water System plants in a manner to ensure reliability as well as optimization of energy and conservation of natural resources. The Concessionaire shall use commercially reasonable efforts, consistent with Prudent Industry Practices, to continuously improve the operating efficiency and use of resources including water for the Chilled Water System.

6) **Design Standards**

- a) The Concessionaire shall maintain and ~~keep up to date~~update every 5 years (starting on the Closing Date) or within 60 Days after a building is added to, or removed from, the Chilled Water System, an accurate Chilled Water System hydraulic model, which may be Pipe-Flo or other similar modeling software, in order to:
 - i. ~~Inform~~inform new buildings being connected to the Chilled Water System of the design pressure drop requirements based on system hydraulic models; and
 - ii. ~~Verify~~verify and maintain system flow velocities according to design standards.

- b) The Concessionaire shall cause the Chilled Water System to adhere to chilled water pipe velocity limits as set forth in the Design Standards, once Approved by the University in accordance with Part II, Section 7(a) hereof.
- c) The Concessionaire shall follow the Design Standards in Appendix F.

7) **Unplanned Outage**

- a) An Unplanned Outage for the General Chilled Water Portion of the Utility System (as defined in Schedule 15 of the Concession Agreement) shall mean the occurrence of one of the following:

- i. Chilled water supply temperature exceeds 50 degrees ~~at any building interface supply point~~ as measured at the chilled water supply of each chilled water plant, to include North Campus Chiller Plant, South Campus Chiller Plant, and McClure Plant, or supply pressure falls below 20 psi as measured at the Chilled Water Pressure Measurement Point for 30 continuous minutes or more ~~or supply pressure at any building interface falls below 20 psi for 30 continuous minutes as measured by the chilled water interface temperature and pressure transmitters identified on Appendix O for Chilled Water System Unplanned Outages as monitoring points, provided that it.~~ It shall not be an Unplanned Outage if the supply temperature or the pressure is below those levels outside the required range (A) if the applicable University building's automation system is not requesting chilled water at that time, (B) if the supply temperature or pressure is changed upon request of the University, or (C) when ambient temperatures exceed the cooling design-day conditions that the Chilled Water System is rated for.

- ii. Chilled water supply is interrupted to a building due to a closed or inoperable distribution valve, leakage, pipe failure, or other system failure on the chilled water distribution system; except in the case where the valve has been closed upon the request of the University.

- iii. The Concessionaire fails to provide sufficient notice for such outage to be a Planned Outage.

- ~~b) An Unplanned Outage for the Chilled Water Tank (Thermal Energy Storage) shall mean the occurrence of one of the following:~~

- ~~i. Failure to maintain a thermocline level of at least 30 at a temperature of 46 degrees or below.~~

- ~~ii. The Concessionaire fails to provide sufficient notice for such outage to be a Planned Outage.~~

- eb) The Concessionaire shall notify the University by calling the University Front Desk Number ~~and the Manager of the Energy Plant which is currently (208)~~

~~885-6271 and this may be updated by notice from the University to the Concessionaire (the “University Energy Plant Number”)~~ if there is an excessive drop in chilled water loop makeup of more than 25 gallons per minute for 5 continuous minutes or an average of 2 gallons per minute level in the Thermal Energy Storage tank of 1.5 inches or more over a 24-hour period.

- dc) If an Unplanned Outage for the Chilled Water System occurs which causes a loss of service to a portion of the Utility System, the Concessionaire shall promptly and diligently, including 24-hour a day service, commence active work, regardless of potential delay by others, to correct the Chilled Water System Unplanned Outage and restore service; unless otherwise approved by the University in its sole discretion.
- ed) If operational issues occur that result in a high loop temperature event (greater than 50 degrees for 30 minutes) for the Chilled Water System, the Concessionaire shall:
- i. ~~Notify~~notify the University by calling the University Front Desk Number;
 - ii. ~~Begin~~begin necessary corrective action; and
 - iii. ~~Provide~~provide updates as needed based on changes in the status of the Chilled Water System (and at least daily) and as more frequently as reasonably requested by the University to UI Facilities Management by calling the University Front Desk Number if an incident exceeds 15 minutes or more.

8) Redundancy

- a) Where ~~possible~~N+1 exists as of the date hereof or at such later date where N+1 comes to exist, the Concessionaire shall thereafter maintain an N+1 level of redundancy for the Chilled Water System. “N+1” is defined as the ability to meet ~~seasonal peak load~~campus design-day cooling loads assuming the largest capacity Utility System Asset of the Chilled Water System is non-functional.
- b) If the Chilled Water System ~~is below~~has an N+1 level of redundancy, and at any point thereafter fails to maintain such N+1 redundancy, the Concessionaire shall promptly and diligently commence active work within 48 hours to correct the loss of system reliability ~~within 48 hours~~.
- c) The Concessionaire shall maintain existing standby generators for the Chilled Water System in accordance with manufacturers’ recommendations and Prudent Industry Practices with the rated capacity of at least the capacity in existence as of the Closing. The University has the right to increase such requirement in its reasonable discretion, which shall be deemed a modification of these Performance Standards under Section 6.3(a) of the Concession Agreement.

- d) The Concessionaire shall perform standby generator testing for existing standby generators per manufacturers' recommendations.
- e) The Chilled Water Business Continuity Plan shall be tested annually in coordination with University Facilities Management staff. The date and time of each test shall be discussed with the University and agreed upon no less than 15 days in advance of such test.

9) **Water Quality**

- a) The Concessionaire shall adhere to the existing chemical and water treatment plan that it establishes as part of the Operations Plan, which treatment plan shall cover the Chilled Water System and reasonably address and prioritize the protection of health, life and safety of University students, employees, faculty and guests. Such plan shall cover frequency and validation of measurement and testing as well as the following items at a minimum:

- i. ~~Scales~~scale and corrosion;
- ii. ~~Microbiological~~microbiological control;
- iii. ~~Copper~~copper corrosion;
- iv. ~~Maintaining~~maintaining closed loop water chemistry; and
- v. ~~Cooling~~cooling tower and condenser water:
 - 1. ~~Scales~~scale and corrosion inhibitor; and
 - 2. ~~Bleach~~bleach or other biocide;

For the South Campus Chiller Plant, monitor and maintain cooling tower cycles ~~in the range of above 2.5 to 4~~ cycles as necessary to keep heat transfer services clean while minimizing water usage. For the North Campus Chiller Plant, monitor and maintain cooling tower cycles ~~in the range of above 5 to 15~~ cycles, utilizing blended water, as necessary to keep heat transfer services clean while minimizing water usage. For the McClure Chiller Plant, monitor and maintain cooling tower cycles ~~in the range of above 2~~ or better cycles, as necessary to keep heat transfer services clean while minimizing water usage.

- b) The Concessionaire shall require the chilled water systems in a new building that is to be connected to the Chilled Water System to be flushed and treated to central plant standards by the building owner or construction team before connecting to the Chilled Water System.

**Part IV - PERFORMANCE STANDARDS –
STEAM AND CONDENSATE SYSTEM**

1) Pressure Requirements

- a) The Concessionaire shall operate the steam portion of the Energy Plant to produce saturated steam for the University Campus distribution between ~~30~~10 psi and ~~60~~70 psi.
- b) The Concessionaire shall ensure that each building served by the Steam and Condensate System maintain a minimum pressure of ~~30~~10 psi.
- c) The Concessionaire shall operate the boilers and main header no higher than 200 psi.
- d) For operation of the Microturbine generators that are part of the Steam and Condensate System (the “Microturbine Generators”), the Concessionaire shall operate the boilers and pressure reducing valves to provide ~~190psi~~ inlet pressure and ~~35 psi~~ outlet pressure as specified by the manufacturer.
- e) The monitoring points to determine compliance with such requirements are set forth on Appendix O.

2) Ongoing Utility System Projects - Cogeneration Plant (Microturbine Generators)

- a) The Concessionaire shall operate the Microturbine Generators that are part of the Steam and Condensate System at Maximum Electrical Power Output within the Pressure Requirements as specified in Part IV, Section 1 above and otherwise in accordance with Prudent Industry Practices, allowing for proper maintenance and service of equipment. “Maximum Electrical Power Output” is the design output capability of the turbine generators for sustained reliable operations.

23) Air Quality Permit with Idaho DEQ

- a) The Concessionaire must notify the ~~EHS by calling~~individual identified by the University Front Desk Number and Idaho DEQ as the “EHS Responsible Official,” as may be changed from time to time by notice to the Concessionaire (the “EHS Responsible Official”) and the Idaho DEQ via email at the e-mail addresses of which the University or Idaho DEQ gives the Concessionaire notice, with any excess emissions (opacity event) that lasts three minutes or more in one hour, within 24 hours from the beginning of the event. The Concessionaire shall complete the DEQ AQ-C9 initial notification form (or any successor form thereto) and attach it to the e-mail notification to the EHS Responsible Official and the Idaho DEQ. The Concessionaire shall provide the EHS Responsible Official with a summary of the actions taken to correct the excess emissions event and the continuous monitoring data for the excess emissions event within 48 hours from the beginning of the event.

34) Line of Demarcation between Concessionaire and University

- a) Except as otherwise described herein, the line of demarcation for the Steam and Condensate System is depicted in Appendix L-4 and will be the point where the steam pipe enters the applicable building and connects to the building isolation valve. Appendix L-4 serves as a representative diagram of the Steam and Condensate System. See also Appendix K-4 for a map and further depiction of the Steam and Condensate System.
- i. All steam piping up to the building isolation valve will be considered part of the Steam and Condensate System.
 - ii. All condensate piping from the condensate receiver pump outlet back to the Energy Plant shall be considered part of the Steam and Condensate System.
- b) The Concessionaire shall be responsible for using existing water and chemical treatment in the Utility Facilities or such alternative treatment methodology to the extent Approved by the University, acting reasonably.

45) Metering

- a) The Concessionaire shall maintain, operate and repair steam condensate meters in accordance with the requirements set forth herein.
- i. The Concessionaire shall ensure the meters are accurate and calibrated to the manufacturer's recommendations (provided that, if any of the meters do not comply with the foregoing standards as of the Closing Date, the Concessionaire shall propose Capital Improvements to rectify such non-compliance within a reasonable period after the Closing Date, and the Concessionaire shall not be liable for such non-compliance until the University has Approved such Capital Improvements and the agreed time for completion of such Capital Improvements has elapsed).
 - b) As part of the Preventive and Predictive Maintenance Plans the Concessionaire shall include a plan to ensure metering accuracy and a metering accountability metric for such meters that are part of the Steam and Condensate System.
 - c) The Concessionaire shall ensure electronic metering occurs at a minimum of ~~60-second~~ 5-minute intervals.
 - d) The Concessionaire shall maintain accurate software, monthly meter data, and provide that data to the necessary University servers for use by the University for campus billing.
 - e) The Concessionaire shall ensure that all new building connections to the Steam and Condensate System are metered at the time of connection.

- f) Plant production meters.
- i. Production meters for the Steam and Condensate System must be in service when equipment is operating, functioning properly and reporting to a data system readily accessible by the University. If a primary production meter fails, causing the Steam and Condensate System (or any portion thereof) to be unable to be operated under control, safely and effectively, the associated equipment shall be shut off until the failure is resolved, and the Concessionaire shall cause such meter to be replaced or repaired as soon as reasonably practicable.
 - ii. Historical data starting after the Closing Date on plant production meters shall be maintained at a minimum of 5-minute intervals and readily accessible for the University's review. Raw data shall be provided to the University in a format that cannot be edited by ~~the~~ Concessionaire. Data will be time stamped with the date, hour (in 24-~~hr.~~-hour format) and minute. Data shall be stored as required by the Record Retention Policy. Prior years' data, to the extent available, shall be maintained for the University's review.
 - iii. Meters shall be calibrated and maintained in accordance with the manufacturer's recommendations. The schedule for such calibration shall follow the Preventive and Predictive Maintenance Plans.

56) **Efficiency**

- a) The Concessionaire shall ensure that each boiler ~~maintain a boiler fuel efficiency of 77% or greater~~ operates within 5% of the annual performance level as defined in Appendix G.
- ~~b) The Concessionaire shall ensure that the water recovery rate from the Hot Lime Softening System must be 99% or greater~~
- eb) The Concessionaire shall measure and record ~~every 8 hours~~ on a daily basis the condensate return rate and condensate hardness rate for the Steam and Condensate System and maintain such records for at least 3 full Years. If the condensate return for the Steam and Condensate System drops more than 3% below the average annual return rate for the preceding 3 Years, then the Concessionaire shall propose a plan to the University to remedy such reduction, and, if Approved by the University, shall implement such plan to the extent within the Utility System.
- dc) The Concessionaire shall operate the Steam and Condensate System in a manner to ensure reliability as well as optimization of energy and conservation of natural resources. The Concessionaire shall use commercially reasonable efforts to continuously improve the operating efficiency and use of resources including water for the Steam and Condensate System.

67) Design Standards

- a) If requested by the University, the Concessionaire shall propose as a Capital Improvement or Material Change an accurate Steam and Condensate System model using modeling software, in order to:
- i. ~~Inform~~inform new buildings being connected to the Steam and Condensate System of the design pressure drop requirements based on system models; and
 - ii. ~~Verify~~verify and maintain system flow velocities.

If Approved by the University, the Concessionaire shall implement, operate and maintain such model such that it remains up to date and accurate.

- b) The Concessionaire shall adhere to the following pipe velocity limits for the Steam and Condensate System:
- i. ~~New~~new piping for the steam portion of the Steam and Condensate System to be installed at 120 feet per second (“fps”) respectively at peak flow; and
 - ii. ~~Existing~~existing piping that exceeds 120 ~~feet per second (“fps”)~~ shall require University approval prior to replacement of the piping causing the velocity that exceeds 120 fps.
- c) Steam distribution lines installed after the Closing Date shall be located in a walkable Tunnel or Utilidor.
- d) The Concessionaire shall follow the Utility Service Connection and Inspection Standard set forth in the Design Standards.

78) Unplanned Outage

- a) An Unplanned Outage for the General Steam Portion of the Utility System (as defined in Schedule 15 of the Concession Agreement) shall mean the occurrence of one of the following at the monitoring points identified on Appendix O for General Steam Portion of the Utility System Unplanned Outages:
- i. Steam pressure at ~~a building supply pressure transmitter~~the furthest point from the Energy Plant in the distribution network is less than ~~30~~10 psi for 15 consecutive minutes or more;
 - ii. Steam supply is interrupted to a building due to ~~loss of compressed air for the building pressure reducing valve,~~ a closed or inoperable building isolation valve, leakage, pipe failure, or other system failure;

except in the case where the valve has been closed upon the request of the University; or

iii. ~~The~~the Concessionaire fails to provide sufficient notice for such outage to be a Planned Outage.

~~b) An Unplanned Outage for the Steam Plant (as defined in Schedule 15 of the Concession Agreement) shall mean the occurrence of one of the following at the monitoring points identified on Appendix O for Steam Plant Unplanned Outages.~~

~~i. The Steam Plant fails to provide at least 30 pi steam pressure to the General Steam Portion of the Utility System.~~

~~ii. The Concessionaire fails to provide sufficient notice for such outage to be a Planned Outage.~~

eb) If an Unplanned Outage of the Steam and Condensate System occurs, which causes a loss of service to a portion of the Utility System, the Concessionaire shall promptly and diligently, including 24-hour a day work, commence active work, regardless of potential delay by others, to correct the Unplanned Outage and restore service; unless otherwise approved by the University in its sole discretion.

c) An outage in the Steam and Condensate System caused solely by operation of the Microturbine Generators at Maximum Electrical Power Output shall not be deemed an Unplanned Outage.

d) If operational issues occur that result in a low steam pressure or event for the Steam and Condensate System, defined as an instance where the Steam and Condensate System is providing steam at less than ~~30~~10 psi for 15 minutes at ~~a building pressure transmitter or any building connected to the Steam and Condensate System.~~ the furthest point from the Energy Plant in the distribution network, the Concessionaire shall:

i. ~~Notify~~notify the University by calling the University Front Desk Number if any portion of the University Campus is affected;

ii. ~~Immediately~~immediately commence operation of the wood-fired and natural gas boilers to provide steam to the University Campus that meets the ~~temperature and~~ pressure requirements set forth herein, which wood-fired and natural gas boilers shall operate until such time as the Unplanned Outage is corrected;

iii. ~~Begin~~begin necessary corrective action; and

iv. ~~Provide~~provide updates every 60 minutes if outdoor temperatures are below 32 degrees, and every 24 hours otherwise, to UI Facilities Management by calling the University Front Desk Number if an incident

exceeds 60 minutes or 24 hours, as applicable, based on the appropriate notification timeline or more;

89) Redundancy

- a) Where ~~possible~~ N+1 exists as of the date hereof or at such later date where N+1 comes to exist, the Concessionaire shall thereafter maintain an N+1 level of redundancy for the Steam and Condensate System. “N+1” is defined as the ability to meet seasonal peak load (reasonably calculated by the Concessionaire using measured historic data) assuming the largest capacity Utility System Asset of the Steam and Condensate System is non-functional.
- b) If the Steam and Condensate System ~~is below~~ has an N+1 level of redundancy, and at any point thereafter fails to maintain such N+1 redundancy, the Concessionaire shall promptly and diligently commence active work within 48 hours to correct the loss of system reliability ~~within 48 hours~~.
- c) The Concessionaire shall ensure that at least one out of two steam lines that provide steam to the University Campus is functional at all times.
- d) Concessionaire shall use a chemical treatment plan for the Steam and Condensate System, as part of the Operations Plan, which must be at least as stringent as the chemical treatment plan existing as of the execution of the Concession Agreement. Such plan shall cover frequency and validation of measurement and shall adhere to ASME boiler water quality standards.
- e) The Concessionaire shall maintain standby electrical backup generators for the Steam and Condensate System in accordance with manufacturers’ recommendations and Prudent Industry Practices with the rated capacity of at least the capacity in existence as of the Closing. The University has the right to increase such requirement in its reasonable discretion, which shall be deemed a modification of these Performance Standards under Section 6.3(a) of the Concession Agreement.
- f) The Concessionaire shall perform standby generator testing per manufacturer’s recommendations.
- g) The Concessionaire shall also include pretreatment standards as part of the Operations Plan, which shall include standards for:
- i. ~~Conductivity~~ conductivity and hardness limits from water treatment plan; and
 - ii. ~~Oxygen~~ oxygen removal de-aerators.
- h) The Concessionaire shall adhere to American Society of Mechanical Engineers boiler water quality standards.

910) Fuel Operations and Storage

- a) The Concessionaire must maintain consistent fuel delivery operations from the solid fuel Supply inventory to the Energy Plant to satisfy the needs of the Energy Plant at all times.
- b) The Concessionaire must maintain the Chip Storage/Drying Facility, to include the scale, covered storage, scale shack, conveyance system, shaker separator, and rolling stock. The rolling stock includes the Kenworth Tractor with Trailer, 950 CAT Front End Loader, Hough Front End Loader and a Ford F-500 truck, and if any of the foregoing require replacement, such replacement shall be considered Capital Improvements.

~~10) Condensate water storage~~

- a) ~~The Concessionaire shall maintain the condensate storage at a continuous 6,000-gallon minimum volume so long as the Steam and Condensate System is not then more than 3% below the average annual condensate return rate for the preceding 3 Years.~~

Part V - PERFORMANCE STANDARDS – ELECTRIC SYSTEM

1) Power Requirements

- ~~a)~~ ~~Concessionaire shall ensure that the Electric System maintains the following at the monitoring points identified on Appendix O for the Electric System:~~
- ~~i.~~ ~~At both the East Substation and the West Substation, the O transformer tap changers to deliver voltage consistent with the voltage then being delivered on the Closing Date with such changes as the University may require and +6%/-5% of nominal per current version of American National Standards Institute (“ANSI”) C84.1, or equivalent; and~~
 - ~~ii.~~ ~~0.95 minimum power factor at the substation buses.~~
- ba) The Concessionaire shall design, procure, install, operate and maintain the Electric System such that it is configured for customer determined building load (as communicated by the University to the Concessionaire) and requirements for reliability and redundancy.
- eb) The Concessionaire shall operate and maintain the Electric System such that it meets the following power quality requirements using SEL revenue grade hardened utility metering including relay protection:
- i. ~~For~~for harmonic distortion, comply with University Design Standards, inclusive of the Avista design and construction standards referenced therein, specifying maximum distortion allowable on the Electric System from connected loads, provided that the University shall cooperate with the Concessionaire to address distortion in excess of the maximum distortion allowable on the Electric System, to the extent such distortion is introduced by a connected load and provided further that if there is any ambiguity or conflict within the Design Standards with respect thereto, the controlling standard shall be IEEE 519; and
 - ii. ~~For~~for voltage sag or swell events, investigate any such event and minimize internal system disruption and take affirmative measures to reduce sensitivity of key utility components to reduce trips from minor sag and/or swell events. Minor sag and/or swell events include brownouts or power bumps, and/or power surges resulting in flickering lights or simple loss of power to low voltage remote notification systems, and or controls serving plants, systems and equipment requiring simple corrective actions to restore functionality.
- dc) Notwithstanding anything to the contrary contained herein, the Concessionaire shall operate the Utility System to participate in a Main Campus curtailment type program as directed by the University, and the Concessionaire shall not be in

breach of any of the requirements of these Performance Standards if it operates in accordance with such curtailment.

2) **Line of Demarcation; Concessionaire, University, and Avista Utility**

- a) Except as depicted in Appendix L-1, or as set forth in [Part V](#), Section 2(b) ~~of this Part V~~ [below](#), the line of demarcation for the Electric System as between the University and the Concessionaire shall be at the point of presence for the service line, which is the building electrical service ~~meter or, absent a~~ [switch](#). [The building electrical service meter, if present, shall be included as part of the Electric System, regardless of its location before or after](#) the building electrical service switch. See also Appendix K-1-A for a map of the Electric System on the Main Campus and Appendix K-1-B for a map of the Electric System, North Farm.
- b) Except as depicted in Appendix L-1, the line of demarcation for the Electric System as between the Concessionaire and any third-party electricity providers (“[External Electric Utilities](#)”) shall be: (i) for the Main Campus, up to the external electrical substation transformers low-side cable terminations; and (ii) for the North Farm, up to and including the main transformer feeding disconnect switches on each building.
- c) All cabling, switchgear, transformers, duct banks, manholes, and vaults and substation buildings and associated infrastructure between the External Electric Utilities and building lines of demarcation (as described herein) shall constitute the Electric System.
 - i. Avista Corporation, or its Affiliate, operates under an easement from the University and maintains its own equipment and the high side transmission lines feeding the two external electrical substations serving the University Campus and the North Farm.
 - ii. Sight perimeter walls chain link fence, access and drainage systems and the SPCC Plan shall be included as part of the Electric System.
- d) The Concessionaire shall review and assume the current University role in complying with the access, operating, interlocking, and station service arrangements between the University and External Electric Utilities systems.
- e) Where the physical line of demarcation within the Electric System is not set forth herein, or is not otherwise apparent, the line of demarcation shall be located on the low voltage side of the relevant building or structure transformer(s).

3) **Metering**

- a) The Concessionaire shall maintain, operate and replace Electric meters in accordance with the requirements set forth herein.

- i. The Concessionaire shall ensure the revenue grade meters are accurate and calibrated to the manufacturer's recommendations (provided that, if any of the meters do not comply with the foregoing standards as of the Closing Date, the Concessionaire shall propose Capital Improvements to rectify such non-compliance within a reasonable period after the Closing Date, and the Concessionaire shall not be liable for such non-compliance until the University has Approved such Capital Improvements and the agreed time for completion of such Capital Improvements has elapsed).
 - ii. Concessionaire shall provide the University with all information from the meter readings, in a format prescribed by the University and in a manner that allows the University to maintain, without interruption, the University's then-current internal system for usage recording and billing.
- b) As part of the Preventive and Predictive Maintenance Plans developed in Section 1(i)(iv), the Concessionaire shall include a plan to ensure metering accuracy and a metering accountability metric for such meters that are part of the Electric System. For the avoidance of doubt, the Concessionaire shall adhere to all applicable requirements with respect to meters set forth in the Design Standards attached as Appendix F. Electric meters to be maintained per requirements of electric metering codes and guidelines.
 - c) The Concessionaire shall either continue to use the existing software programs that the University uses to acquire, monitor and maintain Utility consumption data within the Utility System or use metering software of its choosing, subject to the Approval of such change in the Five-Year Plan by the University. In either case, the Concessionaire shall provide the University reasonable access to view the real-time meter data for all meter sites.
 - d) The Concessionaire shall ensure electronic metering occurs at a minimum of ~~60-second~~5-minute intervals.
 - e) The Concessionaire shall maintain accurate software, monthly meter data, and provide that data to the necessary University servers for use by the University for campus billing, utility assessments.
 - f) The Concessionaire shall ensure that all new building connections to the Electric System are metered in accordance with the Design Standards. Temporary construction power shall be metered and read via manual reads. For new installations coming on-line, at the time permanent power is connected metering shall be in place for manual reads and shall be networked as soon as reasonably practicable meeting the specifications set forth herein.
 - g) Substation and campus feeder meters.
 - i. Main substation feed and customer meters that are part of the Electric System must be in service when equipment is operating, functioning properly and reporting to a data system accessible by the University. If a

meter or its network communications fails, it shall be repaired as expeditiously as possible.

ii. Main ~~substation~~feed meters shall have event capture capability and store wave form level detail during periods of electrical disturbance.

h) The Concessionaire shall maintain Schweitzer Engineering Laboratories (SEL)-735 revenue meters (or an equivalent Approved by the University in its discretion) on all of the substation transformers in existence as of the Closing Date and can also compare meter readings to the Avista Feed Meters where applicable and SEL relays (or an equivalent, in each case, Approved by the University in its discretion). The Concessionaire shall then compare internal meters monthly to billed consumption from the serving utility promptly and shall report such result to the University.

4) **Efficiency**

a) The Concessionaire shall operate the Electric System in a manner to ensure reliability as well as optimization of energy and conservation of natural resources. The Concessionaire shall use commercially reasonable efforts to continuously improve the operating efficiency and use of resources for the Electric System.

5) **Design Standards**

a) The Concessionaire shall adhere to the University's Design Standards and all legal requirements for the Electric System including but not limited to IEEE and NFPA.

b) The Concessionaire is prohibited from installing, constructing or using above grade transmission and distribution lines, except as Approved by the University on a case by case basis.

6) **Unplanned Outage**

a) An Unplanned Outage for the Electric System shall mean the occurrence of one of the following at the monitoring points identified on Appendix O for Electric System Unplanned Outages:

i. ~~A~~a failure at a distribution feeder breaker, or building transformer ~~failure~~, primary fuse or primary switch opens, secondary service protector main or feeder breaker opens, or any other cause determined by the University (acting reasonably) to originate within the Utility System which interrupts service to a building connected to the Electric System (in each case, except where such event is caused by a fault within a building, or other campus infrastructure, beyond the line of demarcation for the Utility System); or

- ii. ~~The~~the Concessionaire fails to provide sufficient notice for such outage to be a Planned Outage.
- b) If an Unplanned Outage of the Electric System occurs which causes a loss of service, the Concessionaire shall promptly and diligently, including 24-hour a day work, commence active work to correct the Unplanned Outage and restore service, regardless of potential delay by others (unless proceeding despite such potential delay by others could reasonably result in further Unplanned Outages). Such updates shall be deemed a modification under Section 6.3(a) of the Concession Agreement.
 - c) If there is an Unplanned Outage of the Electric System, the Concessionaire shall:
 - i. ~~Notify~~notify the University by calling the University Front Desk Number if any portion of the University Campus is affected.
 - ii. ~~Begin~~begin necessary corrective action; and
 - iii. ~~Provide~~provide updates every 24 hours to UI Facilities Management by calling the University Front Desk Number if an incident exceeds 24 hours or more;
 - d) The Concessionaire shall communicate with the University when it becomes aware of an External Electric Utility line or service feed that is out of service and is impacting any University Facilities, or plans to perform such work that could impact reliability for the University.

7) Redundancy

- a) Where ~~possible~~N+1 exists as of the date hereof or at such later date where N+1 comes to exist, the Concessionaire shall thereafter maintain an N+1 level of redundancy for the Electric System. "N+1" is defined as the ability to meet seasonal peak load assuming ~~the largest capacity Utility System Asset of the Electric System~~one of the primary electric feeds is non-functional.
- b) If the Electric System ~~is below~~has an N+1 level of redundancy, and at any point thereafter fails to maintain such N+1 redundancy, the Concessionaire shall promptly and diligently commence ~~active work to correct the loss of system reliability~~active work to correct the loss of system reliability within 48 hours ~~to restore N+1. Such 48-hour period shall not commence until the Concessionaire has obtained any necessary authorization for such work.~~to restore N+1. Such 48-hour period shall not commence until the Concessionaire has obtained any necessary authorization for such work.
- c) Each component of the Electric System shall have at least one independent backup.
 - i. For each ~~substation in the~~electrical feed from the applicable External Electric System Utility, maximum capacity, as set by the applicable

External Electric Utility, shall be met with the loss of a single transformer or bus.

~~ii. For distribution feeders in the Electric System:~~

~~1ii. Buildings~~ For distribution feeders in the Electric System buildings, must be assigned a normal and alternate feed (except for those facilities radially fed); ~~and.~~

~~2. Feeder loading shall be maintained prudently below protective relay settings in accordance with Prudent Industry Practices.~~

iii. For building service substations in the Electric System, they shall be in a main-tie-main configuration for critical facilities such as, research facilities and larger stadiums and may be single-ended for non-critical facilities. This main-tie-main applies to East and West feed interconnectivity.

d) The Concessionaire shall operate, maintain and replace, as necessary, the ~~gas engines~~ electric generator(s) that provide emergency back-up power to ~~certain buildings~~ the Energy Plant and other parts of the Utility System on the University Campus, such that they shall provide at least the quality and quantity of backup service as exists on the Setting Date.

e) The Concessionaire shall participate in annual power-loss testing on the University Campus at such times and in such frequency as reasonably requested by the University.

~~f) The Concessionaire shall operate, maintain and replace, as necessary, the gas engines at North Farm that provide emergency back-up power to certain buildings on the University Campus in the same manner that it is required to operate, maintain and replace the rest of the Utility System, such that they shall provide at least the quality and quantity of backup service as exists on the Effective Date.~~

8) Distribution System Switching

a) The Concessionaire shall maintain a ~~table of relay settings on feeders and substation transformers~~ transformer inventory for the Electric System in accordance with Prudent Industry Practices.

b) The Concessionaire shall provide switching for planned maintenance, curtailment or construction outages for the Electric System. Switching shall result in no unplanned interruption to the University.

- c) Switch loading for the Electric System shall be done as required to comply with the following load limits:
- i. ~~Bus~~bus limits;
 - ii. ~~Transformer~~transformer load limits; and
 - iii. ~~Feeder~~feeder loading limits.
- d) ~~The Concessionaire shall provide low voltage switching and support for building outages.~~
- ed) As requested by the University for planning/design, for the duration of construction of new facilities on the University Campus, the Concessionaire shall provide construction power and support which shall include metering.

Part VI - PERFORMANCE STANDARDS – DOMESTIC WATER SYSTEM

1) Regulatory Requirements

- a) The Concessionaire shall ensure that the Domestic Water System is compliant at all times with all current State of Idaho and Federal Regulatory requirements of the United States Safe Drinking Water Act (40 CFR 141) (the “Safe Drinking Water Act”), all applicable Idaho DEQ Idaho Rules For Public Water Systems, all rules promulgated by the American Water Work Association and the Idaho State Plumbing Code.
- b) For any capital improvements or upgrades or additions to the Domestic Water System made after the Closing Date, the Concessionaire shall ensure that those capital improvements or upgrades or additions to the Domestic Water System meet all applicable Idaho DEQ Idaho Rules For Public Water Systems, all rules promulgated by the American Water Work Association and the Idaho State Plumbing Code 2017.
- c) The Concessionaire shall ensure that the Domestic Water System is ~~operated and maintained by at least two certified State of Idaho certified Drinking Water Distribution class 2 operators for the class of systems its rated at with compliance Idaho APA~~ under the supervision that is required by Idaho Administrative Rules (“IDAPA”) 58.01.08, et. seq., and the Safe Drinking Water Act.
- d) The Concessionaire shall resume responsibility of the operating and maintaining University of Idaho Cross Control Program over the ~~330~~ assemblies that includes annual testing, repairing and replacing if needed by certified State of Idaho certified Backflow Assembly Tester in compliance with the Safe Drinking Water Act, all applicable Idaho DEQ Idaho Rules For Public Water Systems, all rules promulgated by the American Water Work Association and the Idaho State Plumbing Code 2017, each as amended from time to time.
- e) The Concessionaire shall report ~~demand and~~ consumption of domestic water and a water profile to the ~~Director of Utilities and Engineering Services and~~ University or its designated assigns and representatives on a monthly basis no later than the ~~5th day end~~ of the following calendar month ~~and, further, the Concessionaire shall separately notify the University of any variances of more than 2% in the reportable data from the prior.~~ The report will include variance in consumption from the previous years for the given month.

2) Pressure Requirements

- a) The Concessionaire shall ensure that the water being distributed by the Domestic Water System maintains pressure of at least ~~50~~25 psi as measured at the pressure at the base of campus highest elevation water towers ~~as~~ at the meters shown on Appendix O.

b) The Concessionaire shall ensure that the water psi being distributed by the Domestic Water System maintains pressure not above ~~80~~150 psi ~~at the point of connection to any water service~~ as shown on Appendix O.

~~e) The Concessionaire shall ensure that the water psi being distributed by the Domestic Water System maintains pressure not above 125 psi as shown on Appendix O.~~

3) **Line of Demarcation between Concessionaire and University**

a) Except as otherwise described herein, the line of demarcation for the Domestic Water System, including building apparatus for firefighting water and fire ~~Hydrants~~hydrants is at the point of diversion from the mainline or meter whichever occurs first, which is depicted on Appendix L-2-~~B~~. A map showing the Domestic Water System is set forth on Appendix K-2.

b) All ~~Backflow assemblies and domestic water meter~~fire hydrants, premises backflow assemblies, and premises water meters, regardless of the meter location before or after the building or premises backflow assembly, are included within the Domestic Water System ~~on the main service to the buildings, except where the applicable building is not served by the Domestic Water System, in which case no such equipment shall be considered part of the Domestic Water System.~~ All building/secondary pumps, ~~heat exchanger~~equipment, fixtures, and associated building piping shall not be considered part of the Domestic Water System ~~except for backflow assemblies and domestic water meters on main building service.~~

4) **Metering**

a) The Concessionaire shall maintain and operate Domestic Water System meters in accordance with the requirements set forth herein and in the Concession Agreement, provided that if any such meters do not meet the requirements set forth herein and in the Concession Agreement as of the Closing Date, the Concessionaire shall be excused from such compliance until such time as they, whether through completion of an Ongoing Utility System Project or a Capital Improvement made by the Concessionaire and Approved by the University.

i. The Concessionaire shall ensure the meters are accurate and calibrated to the manufacturer's recommendations (provided that, if any of the meters do not comply with the foregoing standards as of the Closing Date, the Concessionaire shall propose Capital Improvements to rectify such non-compliance within a reasonable period after the Closing Date, and the Concessionaire shall not be liable for such non-compliance until the University has Approved such Capital Improvements and the agreed time for completion of such Capital Improvements has elapsed).

ii. Concessionaire shall provide the University with all information from the meter readings, in a format prescribed by the University and in a manner

that allows the University to maintain, without interruption, the University's then-current internal system for usage recording and billing. The Concessionaire-installed smart meters must be read at consistent intervals as described in paragraph (d) of this Section 4.

- b) As part of the Preventive Maintenance and Predictive Maintenance plans developed in Section 1(i)(iv) of these Performance Standards, the Concessionaire shall include a plan to ensure metering accuracy and a metering accountability metric for such meters that are part of the Domestic Water System. For the avoidance of doubt, the Concessionaire shall adhere to all applicable requirements with respect to meters set forth in the Design Standards attached as Appendix F.
- c) The Concessionaire shall continue to use the existing Siemens (SCADA), Software licensed software programs that the University uses to acquire, monitor and maintain Utility ~~consumption~~production data within the Utility System or use metering software of its choosing, subject to the Approval of such change in the Five-Year Plan by the University. In either case, the Concessionaire shall provide the University reasonable access to view the real-time meter data.
- d) The Concessionaire shall ensure electronic metering occurs at a minimum of ~~60-second~~5 minute intervals for consumption meters and 1 day intervals for production meters. Metering read via radio transmitter or other means shall occur on the first of each month for billing purposes.
- e) The Concessionaire shall maintain accurate software, monthly meter data, and provide that data to the necessary University servers for use by the University for campus billing.
- f) The Concessionaire shall ensure that all new building connections to the Domestic Water System are metered at the time of connection and that those meters are networked to the Utility Network as soon as reasonably practicable in order to meet the specifications set forth herein.
- g) Plant production meters.
 - i. Production meters for the Domestic Water System must be in service when equipment is operating, functioning properly and reporting to a data system readily accessible by the University. If a primary production meter fails, causing the Domestic Water System (or any portion thereof) to be unable to be operated under control, safely and effectively, the associated equipment shall be shut off until the failure is resolved, and the Concessionaire shall cause such meter to be replaced or repaired as soon as reasonably practicable.
 - ii. Historical data starting after the Closing Date on plant production meters shall be maintained at a minimum of 5-minute intervals and readily accessible for the University's review. Raw data shall be provided to the University in a format that cannot be edited by Concessionaire. Data will

be time stamped with the date, hour (in 24 hr. format) and minute. To the extent available, Concessionaire shall maintain prior years' data for the University's review.

- iii. Meters shall be calibrated and maintained in accordance with the manufacturer's recommendations. The schedule for such calibration shall follow the Preventive Maintenance and Predictive Maintenance plans developed in Section 1(i)(iv) of these Performance Standards.

5) **Efficiency**

- a) The Concessionaire shall operate the Domestic Water System plants in a manner to ensure reliability as well as optimization of energy and conservation of natural resources. The Concessionaire shall use commercially reasonable efforts to continuously improve the operating efficiency and use of resources, including reduction in water loss from the Domestic Water System.
- b) The Concessionaire will maintain and operate a water loss control program that will mitigate loss over the entire Domestic Water System ~~less than or equal to 2% aggregate loss over the entire Domestic Water System.~~ The Concessionaire shall notify the University if there is excessive Domestic Water System water loss in the system ~~defined as 2% or greater in aggregate at any point(s) in.~~ The Concessionaire will recommend a value for excessive loss within the first four years after the Closing Date, following a comprehensive evaluation of the Domestic Water System; which shall be conducted at the sole expense of the Concessionaire, and the Parties shall, acting reasonably and in good faith, agree upon the value for excessive loss. If the Parties fail to come to such agreement within 45 Days after completion of such evaluation, either Party may refer such dispute to Article 18 of the Concession Agreement.

6) **Design Standards**

- a) If requested by the University, the Concessionaire shall propose as a Capital Improvement or Material Change an accurate Domestic Water System hydraulic model, using modeling software, in order to:
 - i. ~~Inform~~inform new buildings being connected to the Domestic Water System of the design pressure drop requirements based on system hydraulic models; and
 - ii. ~~Verify~~verify and maintain system flow velocities according to design standards.

If Approved by the University, the Concessionaire shall implement, operate and maintain such model such that it remains up to date and accurate.

- b) The Concessionaire shall cause the Domestic Water System to adhere to the following pipe velocity limits:
- i. ~~New~~new piping to be limited to 10 ~~feet per second (“fps”)~~ at peak flow; and
 - ii. ~~New~~new piping velocity ~~at peak flow~~ shall comply with applicable ASTM International standards.
- c) Domestic Water System distribution piping shall be direct buried unless no other practicable option exists other than to place Domestic Water System piping in a Tunnel, provided that the University must Approve that there is no practicable option to direct bury such piping.
- d) All water service and water mains wall penetrations that are part of, or connected to, the Domestic Water System must be links seal and Ductile Iron pipe.
- e) The Concessionaire shall follow the Utility Service Connection and Inspection Standard in the Design Standards and all new Domestic Water System mains must be approved of Idaho DEQ prior to installation.

In furtherance of its obligations under the Concession Agreement, the Concessionaire shall maintain and keep up to date with University of Idaho standards, (IDAPA 58.01.08) (Idaho rules for Public Water Systems) American Water Work Association (“AWWA”) and Idaho State Plumbing Code 2017.

7) **Unplanned Outage**

- a) An Unplanned Outage for the Domestic Water System shall mean the occurrence of one of the following:
- i. ~~Domestic~~domestic water supply to a building served by the Domestic Water System has no water pressure in any area of the building as reported and reasonably verified by the University due to a closed or inoperable isolation valve, leakage, pipe failure, or other system failure on the Domestic Water System for distribution; except in the case where the valve has been closed upon the request of the University;
 - ii. ~~The~~the Domestic Water System has less pressure than 20 psi to main and service lines in accordance with State of Idaho Administrative Rules;
 - iii. ~~Failure~~failure to provide the approved water supply capable of supplying the required fire flow for fire protection water in accordance with ~~applicable Law~~2018 International Fire Code, Section 507, as may be amended in the future; or

- iv. ~~The~~the Concessionaire fails to provide sufficient notice for such outage to be a Planned Outage.
- b) The Concessionaire shall notify the University Front Desk Number if there is excessive Domestic Water System water loss in the Domestic Water System-~~defined as 2% or greater in aggregate at any point(s) in the Domestic Water System,~~ with such excessive loss value to be as determined in accordance with Part VI, Section 5(b) above, and the Concessionaire shall cooperate in good faith with the University to implement such measures to reduce such excessive loss.
- c) If an Unplanned Outage for the Domestic Water System occurs which causes a loss of service to a portion of the Utility System, the Concessionaire shall promptly and diligently, including 24-hour a day service, commence active work, regardless of potential delay by others, to correct the Domestic Water System Unplanned Outage and restore service; unless otherwise Approved by the University in its sole discretion.
- d) If operational issues occur that result in a low water pressure event (lower than 20 psi on any water main for the Domestic Water System as measured at the monitoring point on Appendix O, the Concessionaire shall:
- i. ~~Notify~~notify the University by calling the University Front Desk Number;
 - ii. ~~Notify~~notify Idaho DEQ of low water pressure rule in accordance with IDAPA 58.01.08, part 552.01.b.ii.(1), as may be amended from time to time ;
 - iii. ~~Notify~~notify Local Fire Department if ~~no~~-water service to building fire protection system is impacted;
 - iv. ~~Begin~~begin necessary corrective action, including, if needed to control property damage, by closing water main valve if needed and re-routing flow thru water mains to campus; and if needed provide ~~bottle~~bottled water to patrons; and
 - v. ~~Provide~~provide updates every 24 hours to UI Facilities Management by calling the University Front Desk Number if an incident exceeds 24 hours or more.
- 8) **Redundancy**
- a) Where ~~possible~~N+1 exists as of the date hereof or at such later date where N+1 comes to exist, the Concessionaire shall thereafter maintain an N+1 level of redundancy for the Domestic Water System. “N+1” is defined as the ability to meet seasonal peak load assuming the largest capacity Utility System Asset of the Domestic Water System is non-functional.

- b) If the Domestic Water System ~~is below~~ has an N+1 level of redundancy, and at any point thereafter fails to maintain such N+1 redundancy, the Concessionaire shall promptly and diligently commence active work within 48 hours to correct the loss of system reliability ~~within 48 hours~~.

9) **Water Quality**

- a) The Concessionaire shall ensure compliance by the Domestic Water System with the Safe Drinking Water Act and the Domestic Water Plant operating permit requirements.
- b) The Concessionaire shall ensure compliance with the State standards, set forth in Part VI, Section 1(d) hereof, of any capital improvements or upgrades or additions to the Domestic Water System made after the Closing Date.
- c) The Concessionaire shall ensure compliance with State of Idaho DEQ and EPA sampling monitoring schedules and share records with the University.
- d) The Concessionaire shall require the domestic water systems in a new building that is to be connected to the Domestic Water System to be flushed and treated to central plant standards by the building owner or construction team before connecting to the Domestic Water System.
- e) The Concessionaire shall comply with the Infectious Disease Response Plan attached as Appendix I the Concessionaire shall comply with the Infectious Disease Response Plan attached as Appendix I, as may be amended from time to time upon notice to the Concessionaire.
- f) The Concessionaire shall ensure compliance with AWWA and Idaho DEQ standards on operating, maintaining and servicing water reservoirs.

Part VII - PERFORMANCE STANDARDS – COMPRESSED AIR SYSTEM

1) **Temperature Requirements**

- a) The Concessionaire shall ensure that the compressed air being distributed by the Compressed Air System has the ability to maintain a dew point of 40 degrees or lower ~~at each of the monitoring points in the Utility System for the Compressed Air System as identified on Appendix O when the associated Utility Facility is in service~~ as measured at the output of the air dryers located in the Energy Plant.

2) **Pressure Requirements**

- a) The Concessionaire shall ensure that the compressed air being distributed by the Compressed Air System is maintained at a range from ~~80-90psi~~ 80-90 psi at the main pressure control transmitter for the air system as identified on Appendix O.

3) **Line of Demarcation between Concessionaire and University**

- a) ~~The~~ All air compressors, dryers, and associated equipment within the Energy Plant and distribution piping shall be part of the Compressed Air System. Except as depicted in Appendix L-5, the line of demarcation for the Compressed Air System ~~is located at the foundation of the Energy Plant and is distributed throughout the district energy tunnel network to the building mechanical room in buildings, as depicted on Appendix L-5.~~ as between the University and the Concessionaire shall be the first campus building or bicycle station isolation valve. See also Appendix K-5 for a map of the Compressed Air System.

b) See also Appendix K-5 for a map of the Compressed Air System.

bc) All building or bicycle station piping, valves, and associated equipment shall not be considered part of the Compressed Air System.

4) **MeteringEfficiency**

~~a) Production meters for the Compressed Air System must be in service when equipment is operating, functioning properly and reporting to a data system readily accessible by the University. If a primary production meter fails, causing the Compressed Air System (or any portion thereof) to be unable to be operated under control, safely and effectively, the associated equipment shall be shut off until the failure is resolved, and the Concessionaire shall cause such meter to be replaced or repaired as soon as reasonably practicable.~~

~~b) Historical data on plant production meters shall be maintained and readily accessible for the University's review. Raw data shall be provided to the University in a format that cannot be edited by the Concessionaire. Data will be time stamped with the date, hour (in 24 hr. format) and minute.~~

~~e) Meters shall be calibrated and maintained in accordance with the manufacturer's recommendations (provided that, if any of the meters do not comply with the foregoing standards as of the Closing Date, the Concessionaire shall propose Capital Improvements to rectify such non-compliance within a reasonable period after the Closing Date, and the Concessionaire shall not be liable for such non-compliance until the University has Approved such Capital Improvements and the agreed time for completion of such Capital Improvements has elapsed). The schedule for such calibration shall follow the Preventive Maintenance and Predictive Maintenance plans.~~

5) **Efficiency**

a) The Concessionaire shall operate the Compressed Air System plants in a manner to ensure reliability as well as optimization of energy and conservation of natural resources. The Concessionaire shall use commercially reasonable efforts to continuously improve the operating efficiency and use of resources for the Compressed Air System.

65) **Design Standards**

- a) The Concessionaire shall design and install all Compressed Air System piping in accordance with ASTM standards and University design standards. All piping will be type "K" copper.
- b) The Concessionaire shall follow the Utility Service Connection and Inspection Standard in Design Standards.

76) **Unplanned Outage**

- a) An Unplanned Outage for the Compressed Air System shall mean the occurrence of one of the following:
- i. ~~Compressed~~compressed air supply is interrupted to a building due to a closed or inoperable isolation valve, leakage, pipe failure, or other system failure on the Compressed Air System; except in the case where the valve has been closed upon the request of University; or
- ii. ~~The~~the Concessionaire fails to provide sufficient notice for such outage to be a Planned Outage.
- b) The Concessionaire shall notify the University by calling the University Front Desk Number if the Compressed Air System is running more air compressors than normal to keep up with demand over a 24-hour period.
- c) If an Unplanned Outage for the Compressed Air System occurs which causes a loss of service to a portion of the Utility System, the Concessionaire shall promptly and diligently, including 24-hour a day service, commence active work, regardless of potential delay by others, to correct the Compressed Air System

Unplanned Outage and restore service; unless otherwise approved by the University in its sole discretion.

- d) If operational issues occur that result in an outage of the Compressed Air System, the Concessionaire shall:
- i. ~~Notify~~notify the University by calling the University Front Desk Number if any portion of the University Campus is affected;
 - ii. ~~Begin~~begin necessary corrective action; and
 - iii. ~~Provide~~provide updates every 24 hours to UI Facilities Management by calling the University Front Desk Number if an incident exceeds 24 hours or more.

87) Redundancy

- a) Where ~~possible~~N+1 exists as of the date hereof or at such later date where N+1 comes to exist, the Concessionaire shall thereafter maintain an N+1 level of redundancy for the Compressed Air System. “N+1” is defined as the ability to meet seasonal peak load assuming the largest capacity Utility System Asset of the Compressed air System is non-functional.
- b) If the Compressed Air System ~~is below~~has an N+1 level of redundancy, and at any point thereafter fails to maintain such N+1 redundancy, the Concessionaire shall promptly and diligently commence active work within 48 hours to correct the loss of system reliability ~~within 48 hours~~.

~~[Part VIII – PERFORMANCE STANDARDS – UTILITY SCADA NETWORK SYSTEM~~

~~Intentionally Omitted 1) Availability Requirements~~

- ~~a) The Concessionaire shall ensure that the data infrastructure and network assets for the Utility System that transmit all data gathered by the network devices for the Utility System and transmits all other data and electronic information within the Utility System and all Utility Facilities to the data historians (the “Utility Network”) is maintained in accordance with Prudent Industry Practices and is maintained in a manner that it has available all data information reasonably necessary for safe plant and distribution system operation as well as commodity billing and that it stores all such data and information gathered by the Utility Network.~~

~~2) Line of Demarcation between Concessionaire and University~~

- ~~a) The Utility Network is separated from the University Campus network by a physical Fortinet firewall which will be operated and maintained by the Concessionaire. Data shall be made available outside the Utility Network via an University Approved SCADA and control system server. This server shall exist behind the physical firewall and shall maintain the capability to pass data to a University owned PI Server, which resides on the University’s network, via PI to PI protocol, PI Connector, or other University Approved secure connection. Concessionaire shall have the option to maintain for its own use any other PI system elements, such as a PI AF Server and/or PI Vision capabilities behind the firewall. The University will have the right to determine which PI assets it will utilize on its side, as shown in Appendix P. For clarity, Appendix P illustrates the PI configuration that the Concessionaire will be required to adhere to on the Closing Date. All assets used to manage data on the Utility Network, including the firewall, a PI Server (or any approved successor server) shall be included in the Utility Network System as shown on Appendix P.~~
- ~~b) Additionally, the Utility Network System extends into University Buildings to collect metering data from Utility System Meters. The demarcation of the Utility Network System components within the buildings is also provided in Appendix P.~~

~~3) Utility Network Components~~

- ~~a) The Concessionaire shall monitor, maintain and operate the Utility Network system components in accordance with the requirements set forth herein.~~
- ~~b) The Concessionaire shall provide annually, as part of the Operations Plan, a plan to keep Utility Network components updated with a replacement plan for any outdated equipment. If network equipment ages to the point that it no longer will take updates in security, operating system, or process software provided by the~~

~~developer of such equipment, then the equipment shall be replaced within 6 months after such point.~~

- e) ~~The Concessionaire shall either continue to use the existing GE Global Care, Software Toolbox (OPC) and PI OsiSoft licensed software programs that the University uses to acquire, monitor and maintain Utility consumption data within the Utility System or use software of its choosing, subject to the Approval of such change in the Five Year Plan by the University. In either case, the Concessionaire shall provide the University reasonable access to view the real time data.~~
- d) ~~The Concessionaire shall ensure control and data reliability appropriate for the criticality of the monitored devices.~~
- e) ~~All metering shall be revenue grade where applicable, and will be connected to the Utility Network using a network interface or University Approved telemetry.~~
- f) ~~An Unplanned Outage of the Utility Network shall not be a KPI Event; however, the Concessionaire shall use commercially reasonable efforts to minimize the number and duration of Unplanned Outages of the Utility Network and will, as soon as reasonably practicable following such Unplanned Outage, restore the performance of the Utility Network.~~

4) **Unplanned Outage**

- a) ~~An Unplanned Outage for the Utility Network shall mean the occurrence of one of the following:~~
 - i. ~~Loss of a key component of the Utility Network system that creates immediate operability issues;~~
 - ii. ~~Loss of a key component of the Utility Network system that causes a loss of redundancy in key systems; or~~
 - iii. ~~An unrecoverable loss of utility billing data for a period of more than 24 hours.~~
- b) ~~If an Unplanned Outage for the Utility Network System occurs which causes a loss of service to a portion of the Utility System, the Concessionaire shall promptly and diligently, including 24 hour a day service, commence active work, regardless of potential delay by others, to correct the Utility Network Unplanned Outage and restore service; unless otherwise Approved by the University in its sole discretion.~~

- e) ~~If operational issues occur that result in an outage for the Utility Network System, the Concessionaire shall:~~
 - i. ~~Begin necessary corrective action within 2 hours for Emergency Situations (as defined below), and as soon as reasonably practicable for Urgent Situations (as defined below):~~
- d) ~~An “Emergency Situation” occurs with respect to the Utility Network if there is a (i) loss of network; (ii) loss of server; (iii) loss of PLC (CW interface); (iv) loss of network switch or router; (v) failure of substation relay; or (vi) a water plant issue endangering production.~~
- e) ~~An “Urgent Situation” occurs with respect to the Utility Network if there is: (i) redundancy lost in any network system; (ii) a Utility System meter offline; or (iii) a Complicity client offline.~~

5) **Redundancy**

- a) ~~Where possible, the Concessionaire shall maintain appropriate levels of redundancy for the Utility System Assets that make up the Utility Network System, so that secure and continuous operation can be maintained at all times. As part of such redundancy, the Concessionaire shall adhere to the following backup policy:~~
 - i. ~~Full and incremental backups protect and preserve corporate network information and should be performed on a regular basis for system logs and technical documents that are not easily replaced, have a high replacement cost or are considered critical, consistent with the University’s Institutional Data Backup Policy, attached hereto as Appendix B. Backup systems should be housed in a secure and geographically separate location from the original and isolated from environmental hazards. Backup network components, cabling and connectors, power supplies, spare parts and relevant documentation should be stored in a secure area on-site as well as at other corporate locations. For the avoidance of doubt, backup media, data and other information may be stored on non-physical offsite data storage solutions.~~
 - ii. ~~System databases~~
 - 1. ~~A copy of the most current network and system databases must be made at least twice per month or based on frequency of changes made.~~
 - 2. ~~The lead network administrator is responsible for this activity.~~
 - iii. ~~Access to backup databases and other data are tested annually.~~

Part IX - PERFORMANCE STANDARDS – STORM WATER SYSTEM

1) Regulatory Requirements

- a) The Concessionaire shall ensure that the Storm Water System complies with all applicable Laws and the City of Moscow Storm Water Plan.
- b) For any capital improvements or upgrades or additions to the Storm Water System made after the Closing Date, the Concessionaire shall ensure that those Capital Improvements or Material Changes to the Storm Water System meet the current applicable standards Idaho DEQ, Idaho Rules For Storm Water Systems 58.01.02, State of Idaho Stormwater Best Management Practices, all rules promulgated by the American Water Work Association and applicable Law.

2) Pressure Requirements

- a) The Concessionaire shall ensure that the water being removed by the Storm Water System maintains ~~pressure as~~ required ~~to maintain~~ flow rates such that water does not back up and pool at Storm Water System entry points as identified on Appendix K-6.

3) Water Quality

- a) The Concessionaire shall ensure compliance by the Storm Water System with the Clean Water Act and operating under EPA region 10 permit requirements.
- b) The Concessionaire shall ensure compliance by the Storm Water System with the Clean Water Act and operating under State of Idaho MS4 permit requirements.
- c) The Concessionaire shall ensure storm water collection systems are properly maintained and tested for compliance including all retention ponds, storm water oil separator.

4) Line of Demarcation between Concessionaire and University

- a) The line of demarcation for the Storm Water System between the University and the Concessionaire shall be five feet from the building envelope.
- ab) The Storm Water System shall include all piping, valves, manholes, access points and outfalls used to move storm water from the ~~University Campus grounds~~Storm Water System to the appropriate discharge ~~point, whether into the City of Moscow storm system or Paradise Creek,~~ as identified on Appendix L-6. ~~Appendix L-6 serves as a representative diagram of the Storm Water System.~~ See also Appendix K-~~6-6~~ 6 for a map of the Storm Water System.
- b)- ~~Demarcation of all storm water systems discharging from any building is 5' from the building envelope. The Concessionaire is responsible for the Storm Water~~

~~System starting at the point that is five feet from the structural barrier between the interior and exterior of each building on the University Campus.—~~

5) **Design Standards**

- a) The Concessionaire shall maintain and update on an annual basis an accurate Storm Water System asset condition report which will indicate any deficiencies in the capacity or design of the Storm Water System. This Storm Water System report will also be used to:
 - i. ~~Inform~~inform new buildings being constructed adjacent to the Storm Water System; and
 - ii. ~~Verify~~verify and maintain Storm Water System capacities according to Design Standards.
- b) The Concessionaire shall ~~cause the Storm Water System to~~ adhere to the following ~~storm water pipe velocity limits~~flow capacities for the Storm Water system:
 - i. ~~Storm Water System shall be capable of removing the~~New piping for storm water lines shall convey water from a 24-hour, 75-year ~~rain~~storm event without ~~any failures or pooling~~overflowing.
- c) Storm Water System distribution piping shall be direct buried.

6) **Unplanned Outage**

- a) An Unplanned Outage for the Storm Water System shall mean the occurrence of one of the following:
 - i. Storm Water System fails to remove ~~the storm water from any portion of the University Campus~~or retain on site the runoff volume produced from a 24-hour, 75-year storm event (or less) such that the water causes damage to any property or facility ~~during a 75-year rain event (or less)~~ ~~(, provided that the foregoing shall not constitute an Unplanned Outage to the extent that such damage results from damage~~ ~~resulting from a deficiency,~~ original design, or construction existing at the Closing Date (which is proven by the Concessionaire to the University's reasonable satisfaction) to the extent that the Concessionaire has included the remediation of such deficiency in its initial Five-Year Plan and is diligently pursuing the remediation steps on the timetable set out in such initial Five-Year Plan).
 - ii. Storm water flow is interrupted and is not removed from the University Campus such that the water causes damage to any property or facility due to a closed or inoperable distribution valve, leakage, pipe failure, or other

system failure on the Storm Water System; except in the case where the valve has been closed upon the request of the University.

- b) The Concessionaire shall notify the University by calling the University Front Desk Number if there is a reasonable possibility that the Storm Water System capacity is not sufficient to meet these Performance Standards.
- c) If an Unplanned Outage for the Storm Water System occurs which causes a loss of service to a portion of the Utility System, the Concessionaire shall promptly and diligently, including 24-hour a day service, commence active work, regardless of potential delay by others, to correct the Storm Water System Unplanned Outage and restore service; unless otherwise approved by the University in its sole discretion.
- d) If operational issues occur that result in a reduced Storm Water System capacity event , the Concessionaire shall:
 - i. ~~Notify~~notify the University by calling the University Front Desk Number if any portion of the University Campus is affected;
 - ii. ~~Begin~~begin necessary corrective action; and
 - iii. ~~Provide~~provide updates every 24 hours to UI Facilities Management by calling the University Front Desk Number if an incident exceeds 24 hours or more.

Part X - PERFORMANCE STANDARDS – SANITARY SEWER SYSTEM

1) Pressure Requirements

- a) The Concessionaire shall ensure that the water and other materials being distributed by the Sanitary Sewer System ~~maintains pressure as~~maintain required ~~to maintain~~ flow rates such that sanitary sewer water does not back up into any connected facilities.

2) Line of Demarcation between Concessionaire and University

- a) The line of demarcation for the Sanitary Sewer System between the University and the Concessionaire shall be five feet from the building envelope. Separators, retention tanks, and other equipment used to prevent contaminants such as greases, oils, chemicals, etc. from entering the Sanitary Sewer System shall not be considered part of the Sanitary Sewer System regardless of their location in relation to the line of demarcation.
- ab) The Sanitary Sewer System shall include all piping, valves, manholes and access points used to move wastewater from the University Campus buildings to the appropriate discharge into City of Moscow sewer mainmains as identified on Appendix L-7. ~~Appendix L-7 serves as a representative diagram of the Sanitary Sewer System.~~ See also Appendix K-7 for a map of the Sanitary Sewer System.
- b) ~~Demarcation of all sanitary sewer systems discharging from any building is 5' from the building envelope. The Concessionaire is responsible for the Sanitary Sewer System starting at the point that is five feet from the structural barrier between the interior and exterior of each building on the University Campus.~~

3) Design Standards

- a) The Concessionaire shall cause the Sanitary Sewer System to adhere to the current Idaho State Plumbing Code 2017, American Water Work Association, and all applicable Laws.
- b) Sanitary Sewer System distribution piping shall be direct buried.

4) Unplanned Outage

- a) An Unplanned Outage for the Sanitary Sewer System shall mean the occurrence of one of the following:
- i. ~~Sanitary~~sanitary Sewer System fails to remove the sanitary sewage from any portion of the University Campus such that the sanitary sewage causes damage to any property or facility;
- ii. ~~Sanitary~~sanitary Sewer System flow is interrupted and fails to remove the sanitary sewage water from a facility such that the sanitary sewage causes

damage to any property or facility or creates a situation such that the facility may not be used normally due to a closed or inoperable distribution valve, leakage, pipe failure, or other system failure on the Sanitary Sewer System; except in the case where the valve has been closed upon the request of the University; or

- iii. Aa portion of the University's property served by the Sanitary Sewer System is unable to be operated because the Concessionaire failed to maintain the Storm Water System in accordance with Prudent Industry Practices.
- b) For the avoidance of doubt, it shall not be an Unplanned Outage of the Sanitary Sewer System if an Unplanned Outage is caused by a user of the Sanitary Sewer System (other than the Concessionaire, the Operator or their Representatives) disrupting the Sanitary Sewer System by disposing of items in the Sanitary Sewer System for which it was not intended to be used.
- c) The Concessionaire shall notify the University by calling the University Front Desk Number if there is a reasonable possibility that the Sanitary Sewer System capacity is not sufficient to meet these Performance Standards.
- d) If an Unplanned Outage for the Sanitary Sewer System occurs which causes a loss of service to a portion of the Utility System, the Concessionaire shall promptly and diligently, including 24-hour a day service, commence active work, regardless of potential delay by others, to correct the Sanitary Sewer System Unplanned Outage and restore service; unless otherwise approved by the University in its sole discretion.
- e) If operational issues occur that result in a reduced Sanitary Sewer System capacity event, the Concessionaire shall:
 - i. Notifynotify the University by calling the University Front Desk Number if any portion of the University Campus is affected;
 - ii. Beginbegin necessary corrective action; and
 - iii. Provideprovide updates every 24 hours to UI Facilities Management by calling the University Front Desk Number if an incident exceeds 24 hours or more.

Part XI - PERFORMANCE STANDARDS – RECLAIMED WATER SYSTEM

1) Regulatory Requirements

- a) The Concessionaire shall operate that Reclaimed Water System in compliance with all applicable Laws, the State of Idaho DEQ Permit M-028-03, all rules promulgated by the American Water Work Association and the Idaho State Plumbing Code
- b) For any Capital Improvements or Material Changes to the Reclaimed Water System made after the Closing Date, the Concessionaire shall ensure that those Capital Improvements or Material Changes to the Reclaimed Water System meet the current applicable State of Idaho DEQ Permit M-028-03 (Idaho DEQ) Idaho Rules For Public Water Systems (58.01.17), all rules promulgated by the American Water Work Association and the Idaho State Plumbing Code
- c) ~~The Concessionaire shall ensure that the Reclaimed Water System is operated and maintained by at least two certified State of Idaho certified Wastewater Treatment operators and Wastewater Treatment Operator Land Application licenses for the class of systems its rated at with~~ under the supervision required by IDAPA 58.01.16 and operated in compliance ~~of applicable Laws and State of~~ with Idaho DEQ Permit M-028-03.
- d) The Concessionaire ~~is responsible for reporting demand and consumption~~ shall report production of reclaimed water and a water profile to the ~~Director of Utilities and Engineering Services and University~~ or designated ~~assigns and~~ representatives on a monthly basis, no later than the ~~5th day~~ end of the following calendar month, ~~which. The~~ report shall include information on efficiency, reuse, and ~~consumption~~ production metrics consistent with the University's practice prior to the Closing Date ~~and, further, the Concessionaire shall separately notify the University of any variances of more than 2% in the reportable data from the prior, to include variance in consumption from previous years for the given~~ month.

2) Pressure Requirements

- a) The Concessionaire shall ensure that the water ~~being distributed by the Reclaimed Water System maintains pressure of at least 40 psi, at the backpressure valve of the golf course supply discharge points, as measured at the pressure at the campus highest elevation water towers as shown on Appendix O.~~
- psi b) ~~The Concessionaire shall ensure that the water being~~ distributed by the Reclaimed Water System maintains pressure not above 8150 psi ~~at the point of connection to any water service~~ as shown on Appendix O.
- e) ~~The Concessionaire shall ensure that the water psi distributed by the Reclaimed Water System maintains pressure not above 125 psi as shown on Appendix O.~~

3) **Line of Demarcation between Concessionaire and University**

- a) Except as otherwise described herein, the line of demarcation between the Concessionaire and the University for the Reclaimed Water System, ~~including all shall be at the first isolation valve off the main line. All~~ reclaimed water irrigation systems and irrigation clocks ~~as identified on~~ shall not be included in the Reclaimed Water System. Appendix L-8 ~~and Appendix L-9. Each of Appendix L-8 and Appendix L-9~~ serves as a representative diagram of the Reclaimed Water System. See also Appendix K-8 for a map of the Reclaimed Water System.
- b) The line of demarcation for the Reclaimed Water System serving the University's golf course shall be at the backpressure CLA-Val brand valve, after the isolation valve. The University's golf course holding ponds shall not be part of the Reclaimed Water System.
- c) The line of demarcation between the Concessionaire and the City of Moscow shall be after the discharge monitoring valve at the Wastewater Treatment Plant. Appendix L-9 serves as a representative diagram of the demarcation.

4) **Metering**

- a) The Concessionaire shall maintain and operate Reclaimed Water System meters in accordance with the requirements set forth herein and in the Concession Agreement.
 - i. The Concessionaire shall ensure the meters are accurate and calibrated to the manufacturer's recommendations (provided that, if any of the meters do not comply with the foregoing standards as of the Closing Date, the Concessionaire shall propose Capital Improvements to rectify such non-compliance within a reasonable period after the Closing Date, and the Concessionaire shall not be liable for such non-compliance until the University has Approved such Capital Improvements and the agreed time for completion of such Capital Improvements has elapsed).
 - ii. Concessionaire shall provide the University with all information from the meter readings, in a format prescribed by the University and in a manner that allows the University to maintain, without interruption, the University's then-current internal system for usage recording and billing. The Concessionaire-installed smart meters must be read at consistent intervals as described in paragraph (d) of this Section 4.
- b) As part of the Preventive Maintenance and Predictive Maintenance plans developed in Section 1(i)(iv), the Concessionaire shall include a plan to ensure metering accuracy and a metering accountability metric for such meters that are part of the Reclaimed Water System. For the avoidance of doubt, the Concessionaire shall adhere to all applicable requirements with respect to meters set forth in University of Idaho Standards.

- c) The Concessionaire shall continue to use the existing Siemens (SCADA), Software licensed software programs that the University uses to acquire, monitor and maintain Utility consumption data within the Utility System or use metering software of its choosing, subject to the Approval of such change in the Five-Year Plan by the University. In either case, the Concessionaire shall provide the University reasonable access to view the real-time meter data.
- d) The Concessionaire shall ensure electronic metering occurs at a minimum of ~~60-second~~ 1-day intervals for production meters. Metering read via radio transmitter or other means shall occur on the first of each month for billing purposes.
- e) The Concessionaire shall maintain accurate software, monthly meter data, and provide that data to the necessary University servers for use by the University for campus billing.
- f) The Concessionaire shall ensure that all new ~~building~~ Domestic Reclaimed Water System are metered at the time of connection and that those meters are networked to the Utility Network as soon as reasonably practicable in order to meet the specifications set forth herein.
- g) Plant production meters.
- i. Production meters for the Reclaimed Water System must be in service when equipment is operating, functioning properly and reporting to a data system readily accessible by the University. If a primary production meter fails, causing the Reclaimed Water System (or any portion thereof) to be unable to be operated under control, safely and effectively, the associated equipment shall be shut off until the failure is resolved, and the Concessionaire shall cause such meter to be replaced or repaired as soon as reasonably practicable.
- ii. Historical data on plant production meters starting after the Closing Date for plant production meters shall be maintained and readily accessible for the University's review. Raw data shall be provided to the University in a format that cannot be edited by the Concessionaire. Data will be time stamped with the date, hour (in 24 hr. format) and minute. Data shall be stored in the Utility Network as required by the Record Retention Policy. Prior years' data, to the extent available, shall be maintained for the University's review.
- iii. Meters shall be calibrated and maintained in accordance with the manufacturer's recommendations. The schedule for such calibration shall follow the Preventive Maintenance and Predictive Maintenance plans developed in Section 1(i)(iv).

5) **Efficiency**

- a) The Concessionaire shall operate the Reclaimed Water System plants in a manner to ensure reliability as well as optimization of energy and conservation of natural resources and, in any event, in accordance with the requirements set forth herein and in the Reclaimed Water Permit attached hereto as Appendix M. The Concessionaire shall use commercially reasonable efforts to continuously improve the operating efficiency and use of resources, including reduction in water loss from the Reclaimed Water System. The Concessionaire will maintain and operate a water audit and water loss control program serving to mitigate loss over the entire Reclaimed Water System in accordance with the provisions of the Reclaimed Water Permit attached hereto as Appendix M.

6) **Design Standards**

- a) If requested by the University, the Concessionaire shall propose as a Capital Improvement or Material Change an accurate Reclaimed Water System hydraulic model, using modeling software, in order to:
- i. ~~Inform~~inform new buildings being connected to the ~~Domestic~~Reclaimed Water System of the design pressure drop requirements based on system hydraulic models; and
 - ii. ~~Verify~~verify and maintain system flow velocities according to design standards.
- ~~If Approved by the University, the Concessionaire shall implement, operate and maintain such model such that it remains up to date and accurate.~~
- b) The Concessionaire shall ~~cause~~design and construct the Reclaimed Water System to adhere to the following pipe velocity limits:
- i. ~~New~~new piping to be limited to 10 ~~feet per second (“fps”)~~ at peak flow; and
 - ii. ~~New~~new piping velocity ~~at peak flow~~ shall comply with applicable ASTM International standards.
- c) Reclaimed Water System distribution piping shall be direct buried unless no other practicable option exists other than to place Reclaimed Water System piping in a Tunnel, provided that the University must Approve that there is no practicable option to direct bury such piping.
- d) All water service and water mains wall penetrations must be links seal and Ductile Iron pipe.

- e) The Concessionaire shall follow the Utility Service Connection and Inspection Standard in the Design Standards and all new reclaimed water mains must be approved of Idaho DEQ prior install.
- f) The Concessionaire shall maintain and keep up to date with University of Idaho standards, (IDAPA 58.01.16) State of Idaho Wastewater Rules (IDAPA 58.01.17) Rules for Reclamation and Reuse of Municipal and Industrial AWWA (American Water Work Association) (Idaho State Plumbing Code 2017).

7) Unplanned Outage

- a) An Unplanned Outage for the Reclaimed Water System shall mean the occurrence of one of the following:
 - i. ~~Reclaimed~~ water supply (regardless of the source of water) to an irrigation system served by the Reclaimed Water System has no water pressure in any area of the irrigation system as reported and reasonably verified by the University due to a closed or inoperable distribution valve, leakage, pipe failure, or other system failure on the Reclaimed Water System for distribution; except in the case where the valve has been closed upon the request of the University; or
 - ii. ~~The~~the Concessionaire fails to provide sufficient notice for such outage to be a Planned Outage.
- b) The Concessionaire shall notify the University Front Desk Number if there is ~~greater than 2% excessive Reclaimed Water System~~ water loss ~~in aggregate at any point(s)~~ in the Reclaimed Water System. Within the first four (4) years after the Closing Date, the Concessionaire will perform a comprehensive evaluation of the Reclaimed Water System and recommend an aggregate loss percentage. The Parties shall, acting reasonably and in good faith, agree upon the value for an aggregate loss percentage. If the Parties fail to come to such agreement within forty-five (45) Days after completion of such evaluation, either Party may refer such dispute to Article 18 of the Concession Agreement. Once the aggregate loss is agreed, then the Concessionaire shall provide the University with notice any time the Reclaimed Water System exceeds the aggregate loss, and the Concessionaire shall cooperate in good faith with the University to implement such measures to reduce such excessive loss.
- c) The Concessionaire shall respond to an emergency water leak with-in timely matter and assess the situation and take action if needed to control property damage by closing water main valve if needed and re-routing flow thru water mains to the University Campus.
- d) If an Unplanned Outage for the Reclaimed Water System occurs which causes a loss of service to a portion of the Utility System, the Concessionaire shall promptly and diligently, including 24-hour a day service, commence active work, regardless of potential delay by others, to correct the Reclaimed Water

System Unplanned Outage and restore service; unless otherwise Approved by the University in its sole discretion.

- e) If operational issues occur that result in a low water pressure event (lower than 20 psi on any water main for the Reclaimed Water System) the Concessionaire shall:
- i. Notify the University by calling the University Front Desk Number if any portion of the University Campus is affected.
 - ~~ii. Begin necessary corrective action; and if needed provide bottled water to users of the Reclaimed Water System;~~
 - ~~iii.~~ Provide updates every 24 hours to the University by calling the University Front Desk Number if an incident exceeds 24 hours or more.

8) Redundancy

- a) Where ~~possible~~ N+1 exists as of the date hereof or at such later date where N+1 comes to exist, the Concessionaire shall thereafter maintain an N+1 level of redundancy for the Reclaimed Water System. “N+1” is defined as the ability to meet seasonal peak load assuming the largest capacity Utility System Asset in the distribution system of the Reclaimed Water System is non-functional.
- b) If the Reclaimed Water System ~~is below~~ has an N+1 level of redundancy, and at any point thereafter fails to maintain such N+1 redundancy, the Concessionaire shall promptly and diligently commence active work within 48 hours to correct the loss of system reliability ~~within 48 hours~~.

9) Water Quality

- a) The Concessionaire shall ensure compliance by the Reclaimed Water System with State of Idaho Reuse operating Permit M-028-03 requirements.
- b) The Concessionaire shall ensure compliance with State of Idaho DEQ sampling monitoring schedules. The Concessionaire shall inform the university’s Department of Environmental Health and Safety immediately of any water leaks.
- c) The Concessionaire shall be required to maintain and operate the University of Idaho Reuse plant in compliance with DEQ regulations.
- ~~d) The Concessionaire shall comply with the Legionella Exposure Control Plan.~~
- ed) The Concessionaire shall ensure compliance with AWWA and State of Idaho DEQ standards on operating, maintaining and servicing water reservoirs, Lagoons.

LIST OF APPENDICES

Appendix A	-	Surveillance Procedures
Appendix B	-	Institutional Data Backup Policy
Appendix C	-	Facilities Emergency Management Plan
Appendix D	-	Asbestos Management Program
Appendix E	-	Reserved
Appendix F	-	Design Standards
Appendix G	-	Utility System Operating Efficiency Metrics
Appendix H	-	[Intentionally Omitted]
Appendix I	-	Infectious Disease Response Plan
Appendix J	-	Reserved
Appendix K	-	Utility Maps
Appendix K-1-A	-	Electric System
Appendix K-1-B	-	Electric System, North Farm
Appendix K-2	-	Domestic Water System
Appendix K-3	-	Chilled Water System
Appendix K-4	-	Steam and Condensate System
Appendix K-5	-	Compressed Air System
Appendix K-6	-	Storm Water System
Appendix K-7	-	Sanitary Sewer System
Appendix K-8	-	Reclaimed Water System
Appendix L	-	Line of Demarcation
Appendix L-1	-	Electric System
Appendix L-2-A	-	Domestic Water System; Fire Water Line of Demarcation Case
Appendix L-2-B	-	Demarcation
Appendix L-3	-	Chilled Water System
Appendix L-4	-	Steam and Condensate System
Appendix L-5	-	Compressed Air System
Appendix L-6	-	Storm Water System
Appendix L-7	-	Sewage System
Appendix L-8	-	Reclaimed Water System (University Golf Course Line and Irrigation
Appendix L-9-A	-	Lines)
Appendix L-9-B	-	Reclaimed Water System (City of Moscow Line)
Appendix M	-	Reclaimed Water Permit
Appendix N	-	Reserved
Appendix O	-	Monitoring Points

Appendix P	-	Utility Network Map Reserved
Appendix Q	-	Reserved
Appendix R	-	Reserved
Appendix S	-	Reserved
Appendix T	-	Reserved
Appendix U	-	Safety, Health and Environment Policy
Appendix V	-	Tunnel Security Requirements / Confined Space Protocols
Appendix W	-	Reserved
Appendix X	-	Policies and Procedures for use of University's IT Network Reserved
Appendix Y	-	Communication Systems and Information Technology Protocol
Appendix Z	-	Reserved
Appendix AA	-	Commercial Drivers Training Program
Appendix BB	-	IT System Responsibility

Summary report:	
Litera Compare for Word 11.6.0.100 Document comparison done on 3/26/2024 10:39:23 PM	
Style name: JD Color With Moves	
Intelligent Table Comparison: Inactive	
Original DMS: iw://naiweb.firm.jonesday.net/NAI/1512015664/12	
Modified DMS: iw://naiweb.firm.jonesday.net/NAI/1531701001/11	
Changes:	
<u>Add</u>	539
Delete	528
Move From	9
<u>Move To</u>	9
<u>Table Insert</u>	1
Table Delete	2
<u>Table moves to</u>	0
Table moves from	0
Embedded Graphics (Visio, ChemDraw, Images etc.)	0
Embedded Excel	0
Format changes	0
Total Changes:	1088

APPENDIX G

System Operating Efficiency Reporting

1. Boiler efficiencies
 - a. Boiler A (Nebraska – wood): 76%
 - b. Boiler B (Cleaver Brooks – gas): 85%
 - c. Boiler C (Babcock and Wilcox – gas): 78%
 - d. Boiler D (Combustion Engineering – gas): 85%
2. Thermal efficiency of District Energy Plant (at maximum wood boiler/turbine capacity)
 - a. 69%
3. District Energy Plant steam in plant use, total use (K pounds) and % of boiler production
 - a. <1% of boiler production
4. District Energy Plant hot lime softener blowdown rate (%)
 - a. <1% of total throughput
5. Steam distribution losses (%)
 - a. <2%
6. Condensate return (%)
 - a. 98%
7. Chiller efficiency (kW/ton and steam pounds/ton)
 - a. Carrier single-effect absorber: 14 lb/ton
 - b. Armstrong/SmardT centrifugal: 0.49 kW/ton
 - c. York centrifugal: 0.57 kW/ton
8. South Campus Chiller Plant electric consumption
 - a. 21.25 kW at 0% chiller load / 1031.38 kW at 100% chiller load
9. Chilled Water loop average make-up
 - a. Summer: 5,000 gal/month / Winter: 15,000 gal/month
10. Water Plant efficiency
 - a. Well 3 pump efficiency: 69%
 - i. 0.166 kW/GPM
 - b. Well 4 pump efficiency: 61%
 - i. 0.186 kW/GPM
11. Water system losses (Mgal)
 - a. 4.9 Mgal Approximately 2% of the annual use

APPENDIX G

System Operating Efficiency Reporting

	Metric	UOM	Value
	1 District Energy Plant		
1a	Boiler A performance	PS/BDT	12,000
1b	Boiler B performance	PS/therm	76.0
1c	Boiler C performance	PS/therm	76.0
1d	Boiler D performance	PS/therm	76.0
1e	Thermal efficiency of Energy Plant	%	75.0
1f	Condensate return rate	%	85.0
	2 North Campus Chiller Plant		
2a	Carrier absorber performance	ton/PS	0.047
	3 South Campus Chiller Plant		
3a	SmardT chiller #1 performance	ton/kWh	1.95
3b	SmardT chiller #2 performance	ton/kWh	1.95
3c	York performance	ton/kWh	1.58
	4 McClure Chiller Plant		
4a	McClure chiller performance	ton/kWh	0.55
	5 Chilled Water Loop Make-Up		
5a	Summer	gal	5,000
5b	Winter	gal	15,000
	6 Water Systems		
6a	Well 3 pump performance	gal/kWh	400
6b	Well 4 pump performance	gal/kWh	350
6c	Reclaimed pump performance	gal/kWh	140
	7 East Electric Feed		
7a	Average power factor	dim	0.80
7b	Peak amps	A	200
7c	Balance	%	50
	8 West Electric Feed		
8a	Average power factor	dim	0.80
8b	Peak amps	A	200
8c	Balance	%	50

APPENDIX L

Lines of Demarcation

APPENDIX L-1

Electric Line of Demarcation

Moscow Campus

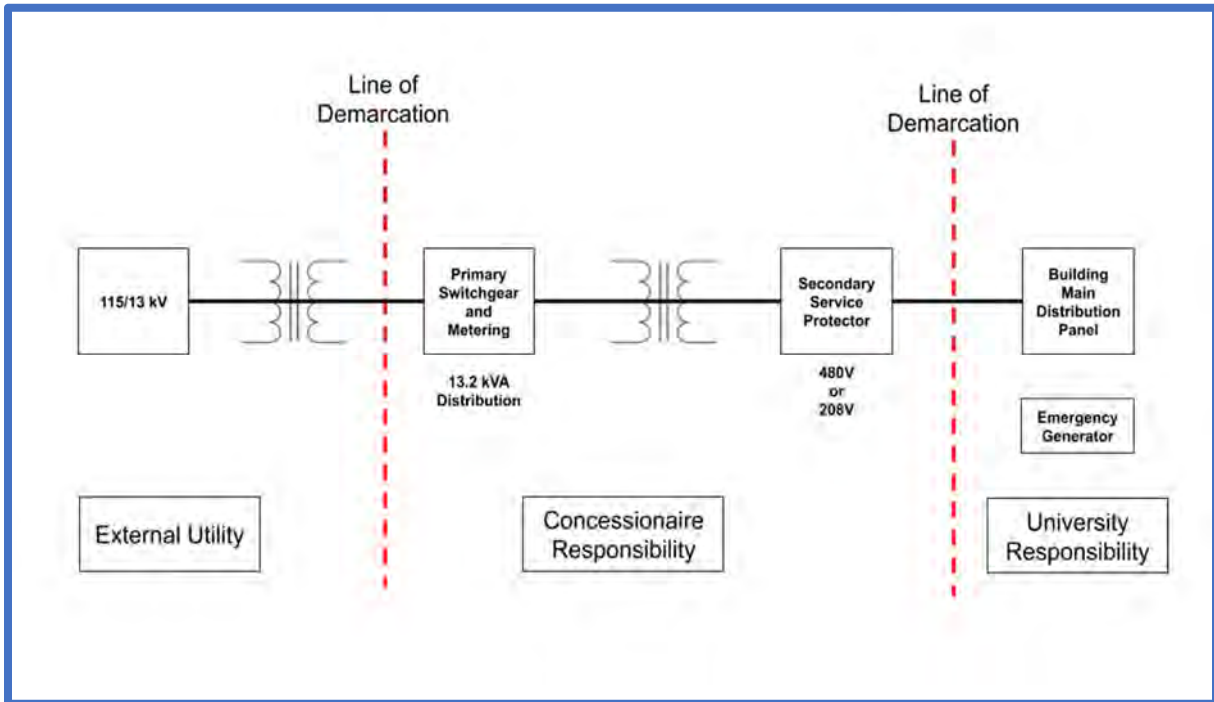

APPENDIX L-2-A
Domestic Water Line Demarcation – Fire Line of Demarcation Case 1

Moscow Campus

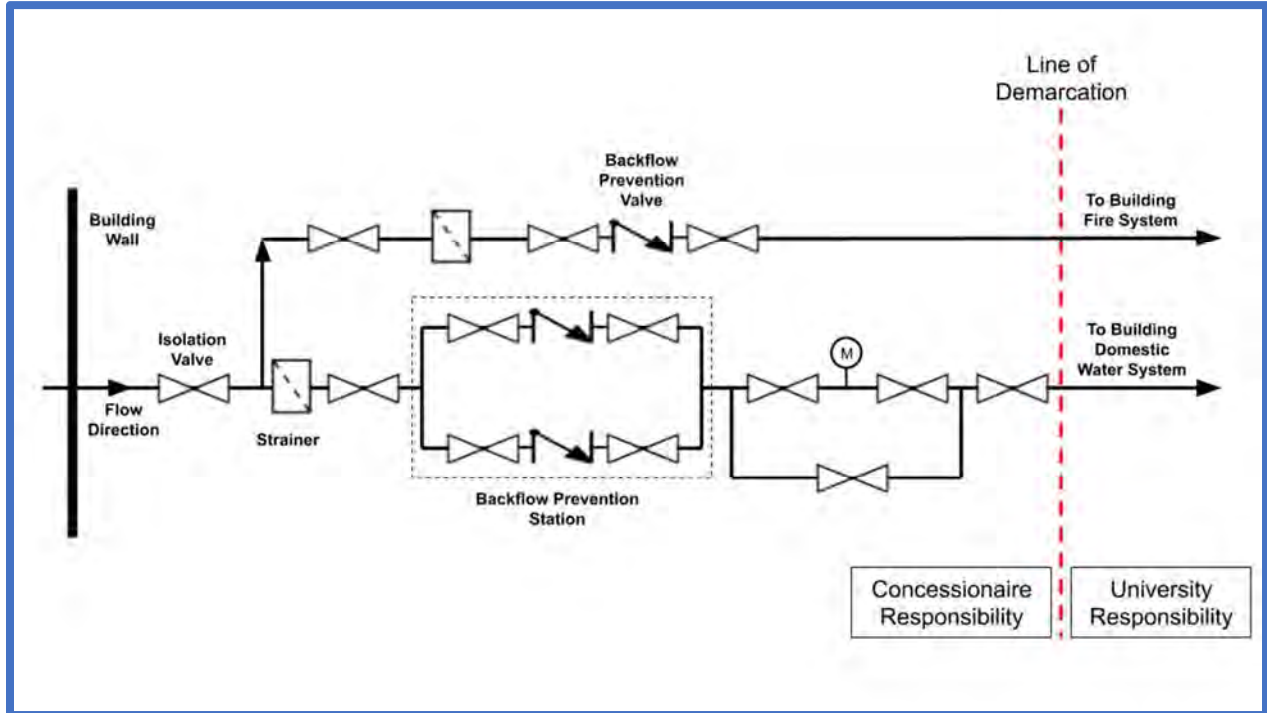

APPENDIX L-2-B
Fire Water Line of Demarcation-Case 2

Moscow Campus

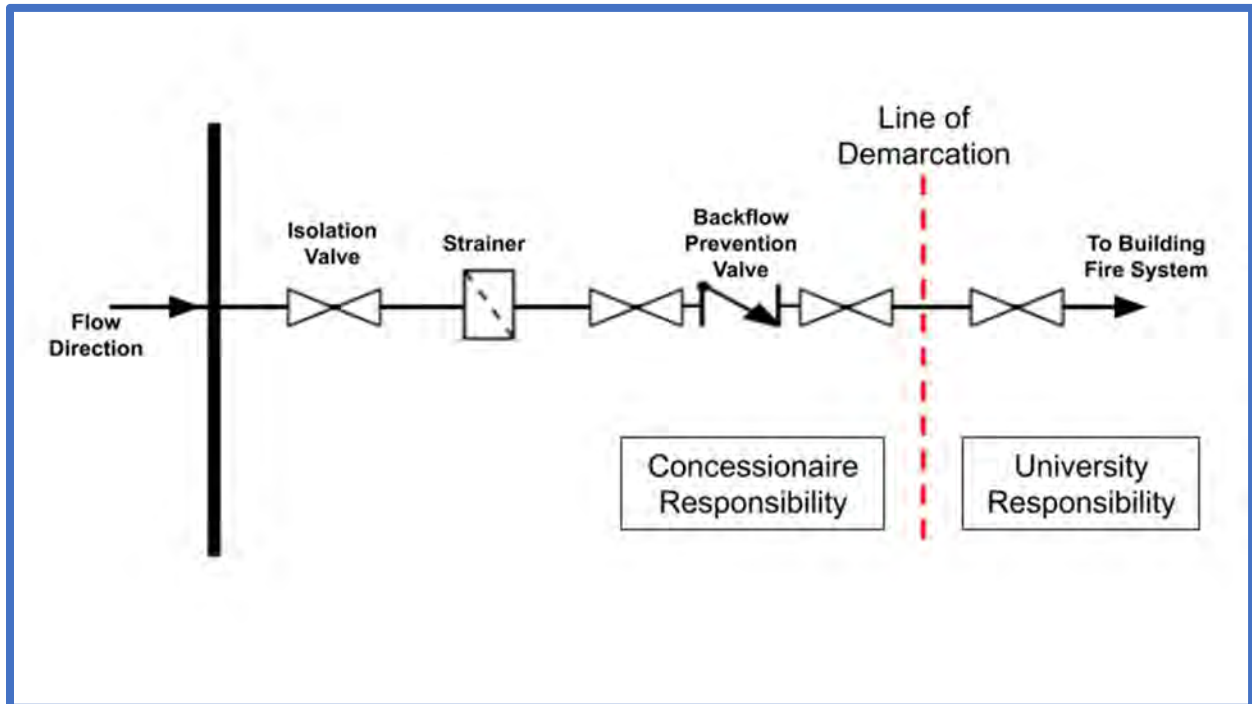

APPENDIX L-3
Chilled Water Line of Demarcation

Moscow Campus

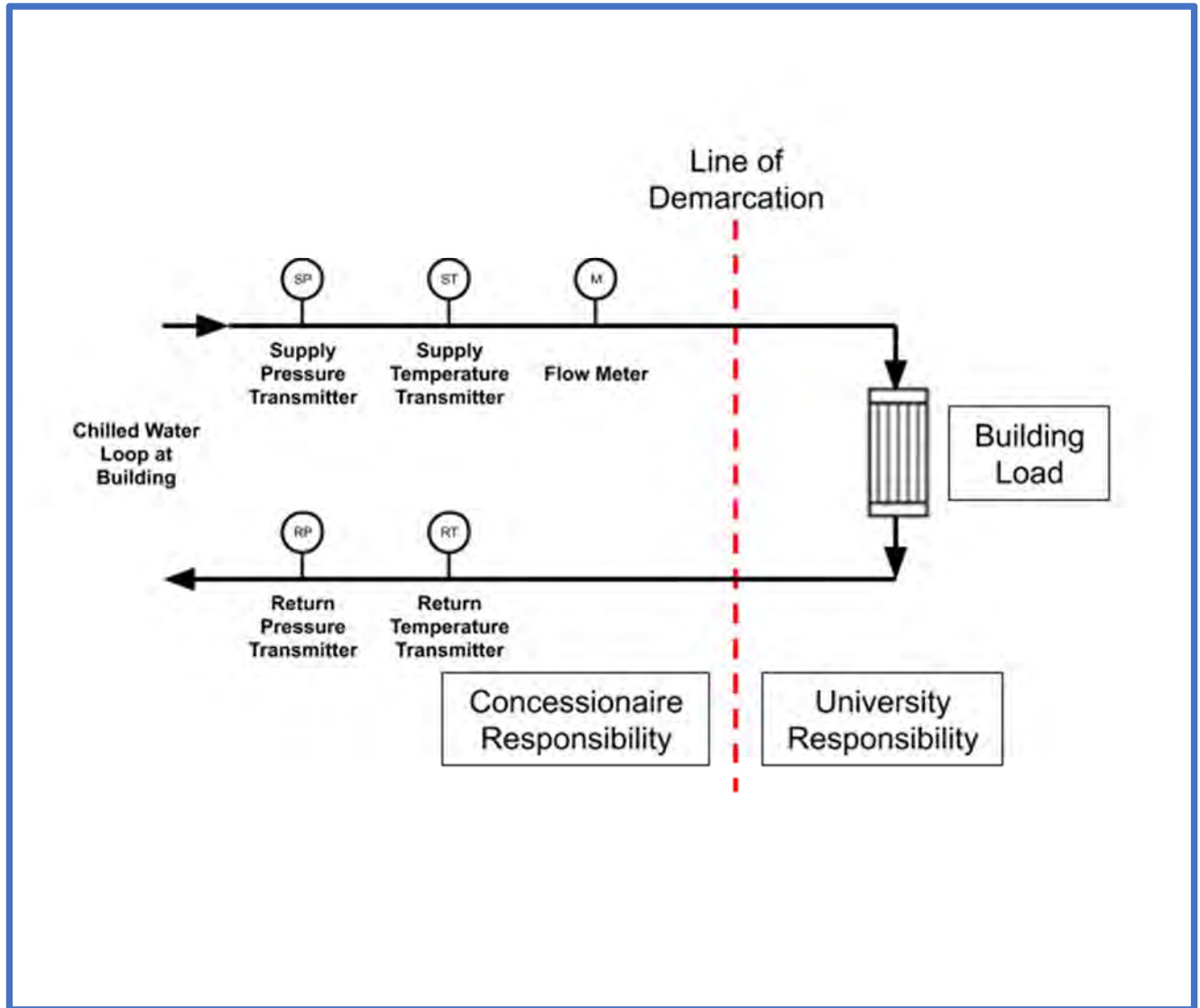

APPENDIX L-4
Steam and Condensate Line of Demarcation

Main Campus Line of Demarcation

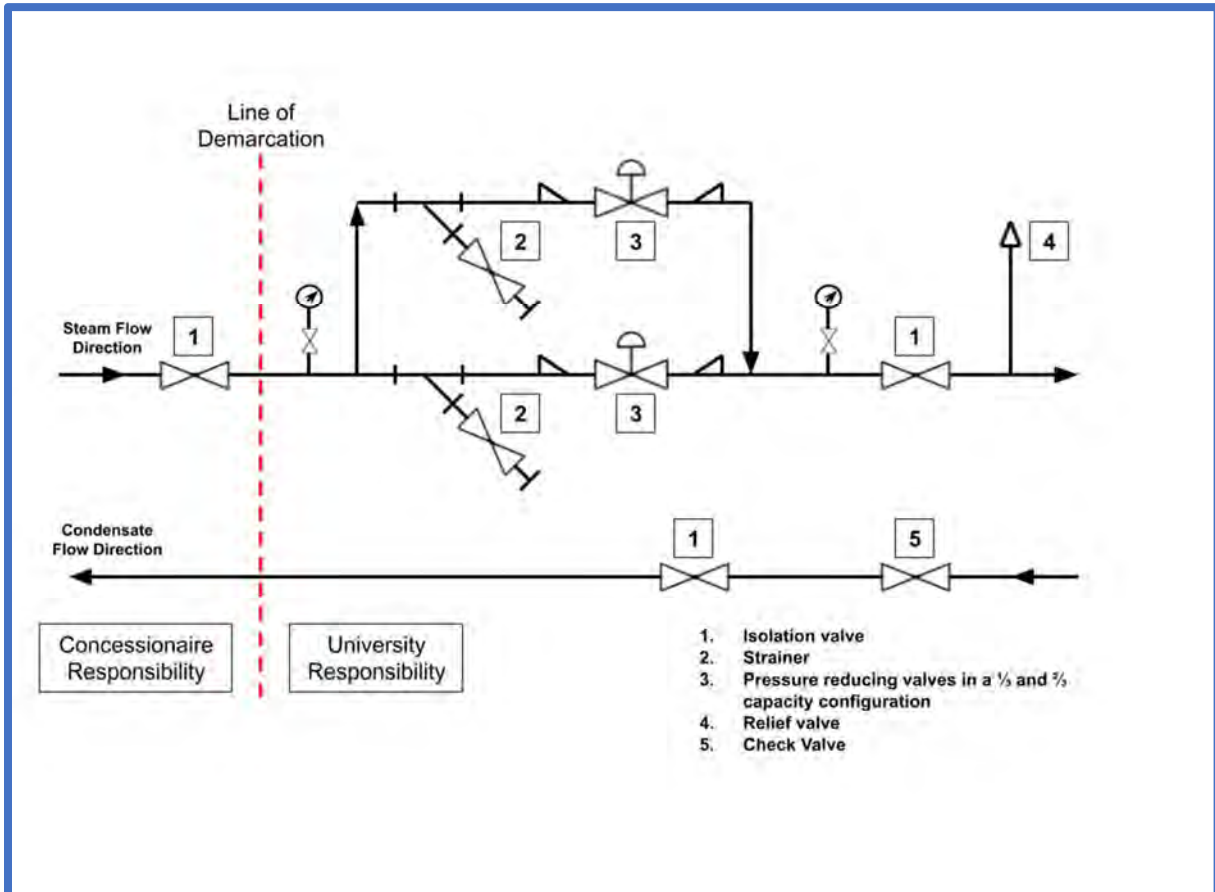

APPENDIX L-5

Compressed Air Line of Demarcation

Main Campus Line of Demarcation

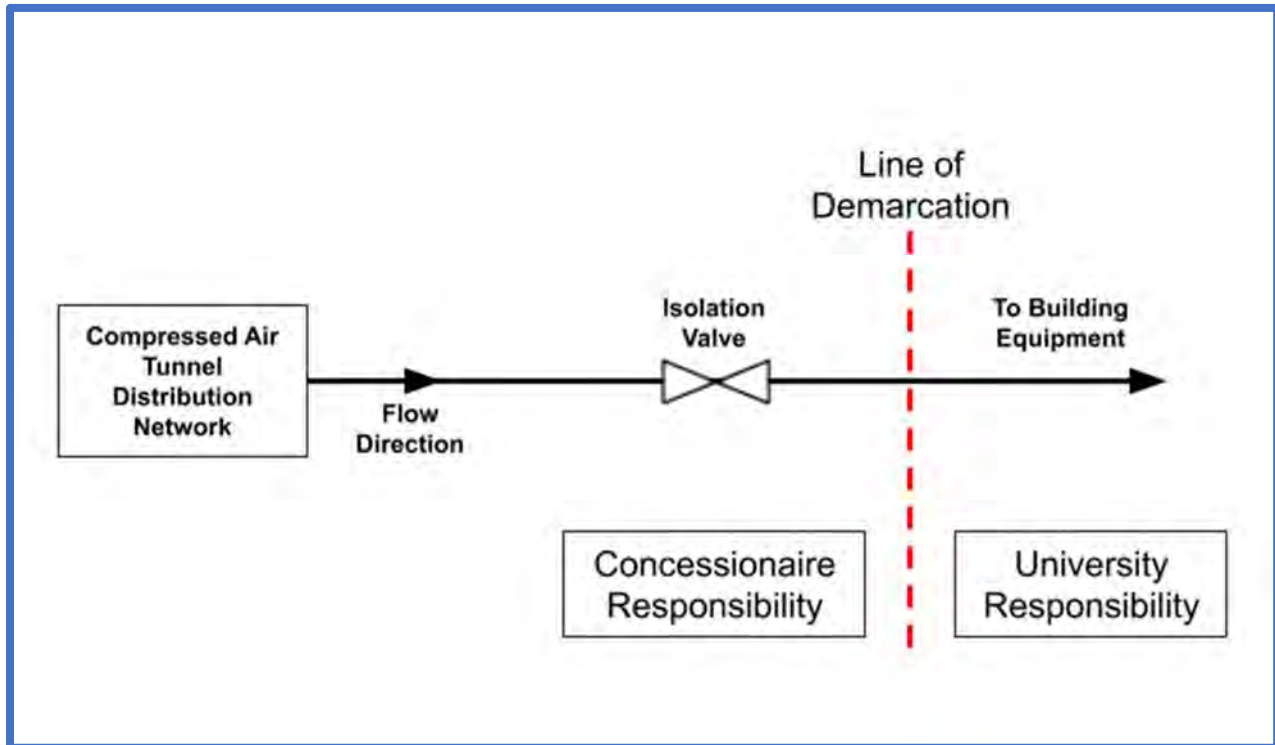

APPENDIX L-6
Storm Water Line of Demarcation

Main Campus Line of Demarcation – Off building storm drain leaders

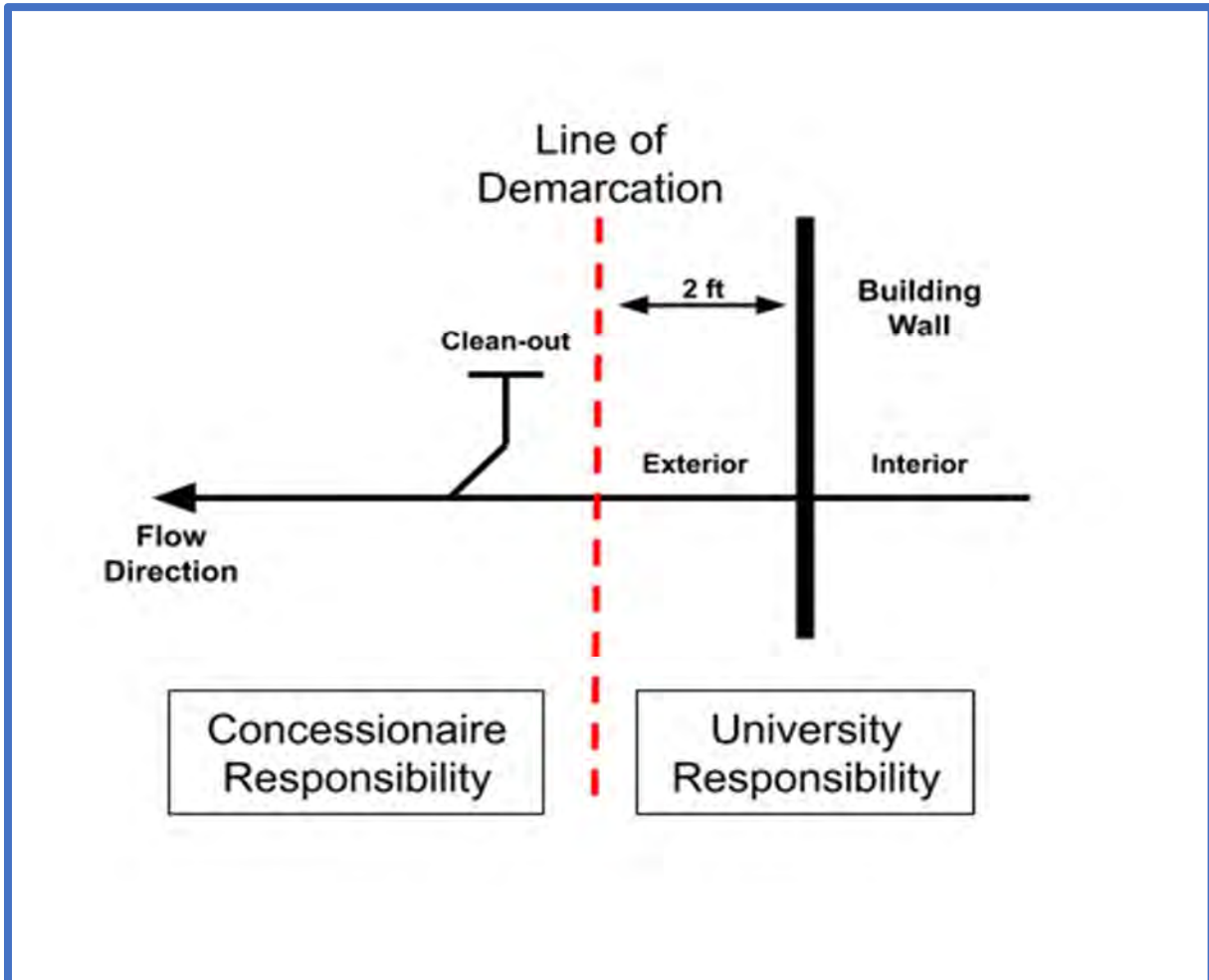

APPENDIX L-7
Sanitary Sewer Line of Demarcation

Main Campus Line of Demarcation

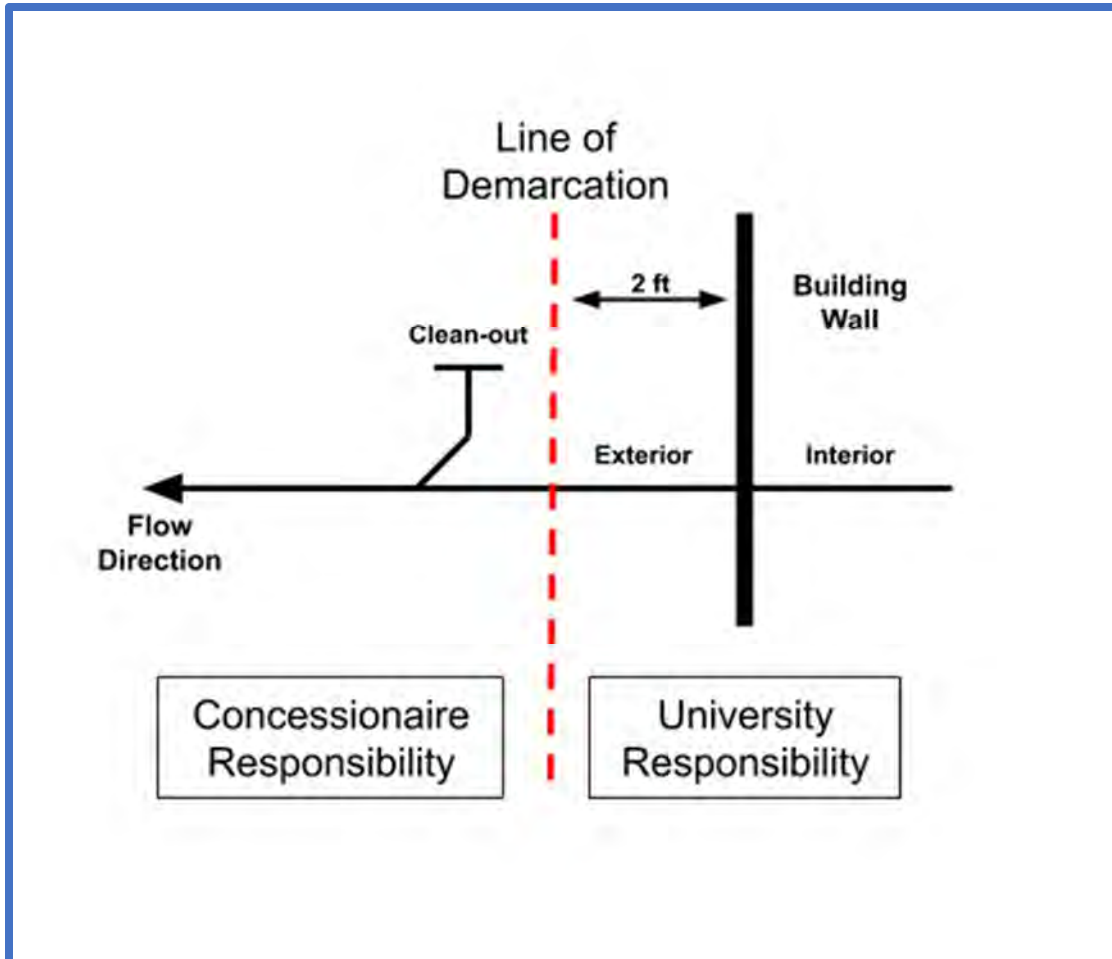

APPENDIX L-8
Reclaimed Golf-Course Service Line of Demarcation
w/University of Idaho Golf Course

Main Campus Line of Demarcation

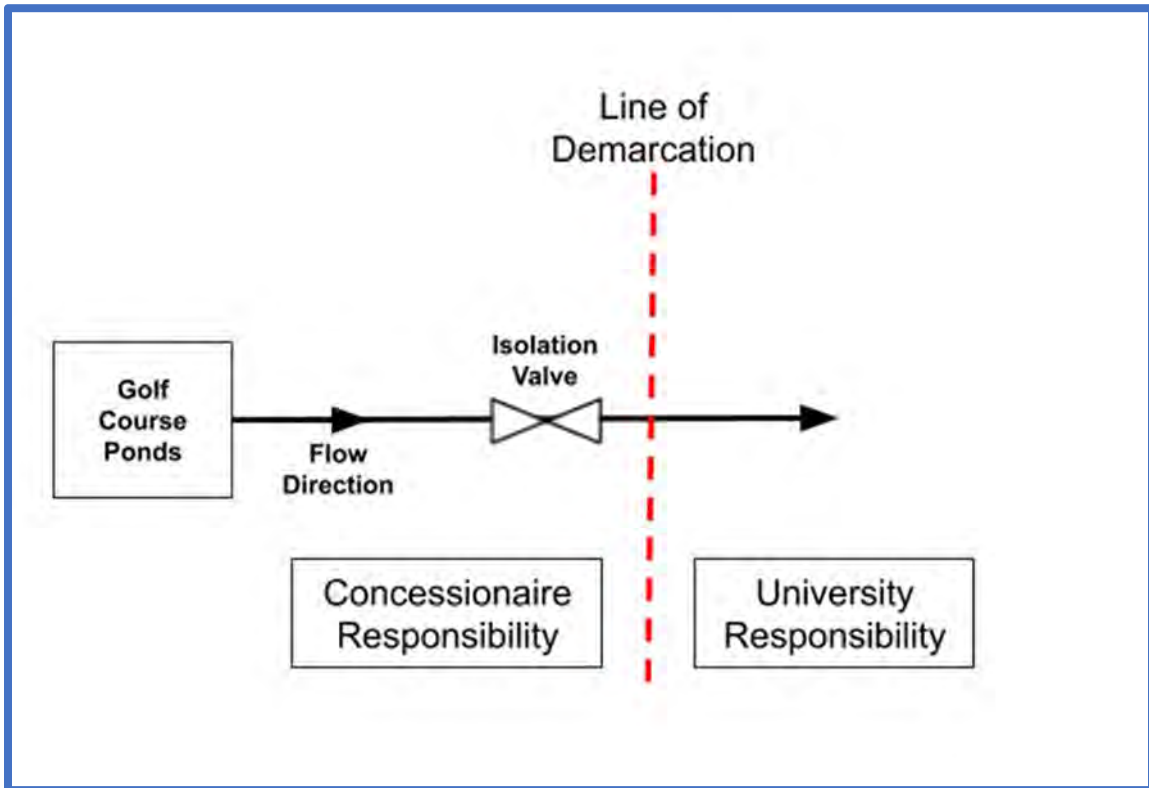

APPENDIX L-9-A
Reclaimed Line of Demarcation
w/ City of Moscow WWTP

Main Campus Line of Demarcation

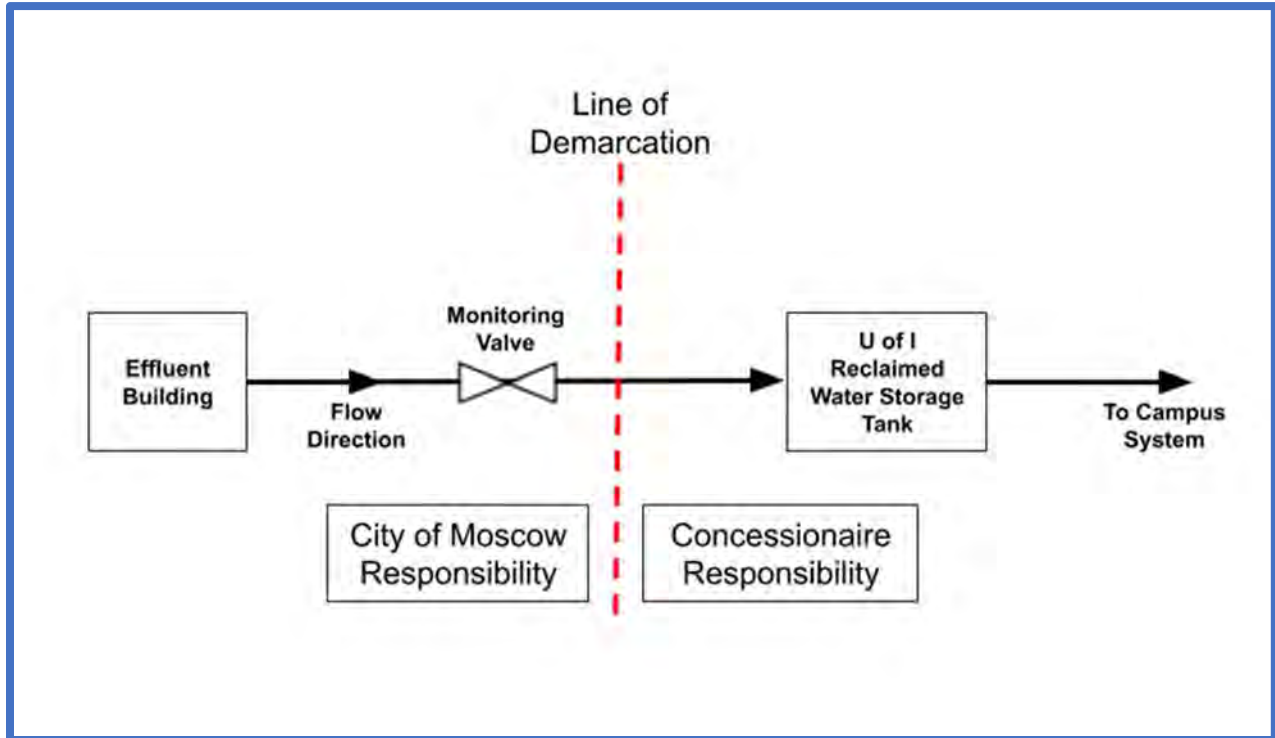

APPENDIX L-9-B
Reclaimed Irrigation Line of Demarcation
w/ University Irrigation Lines

Main Campus Line of Demarcation

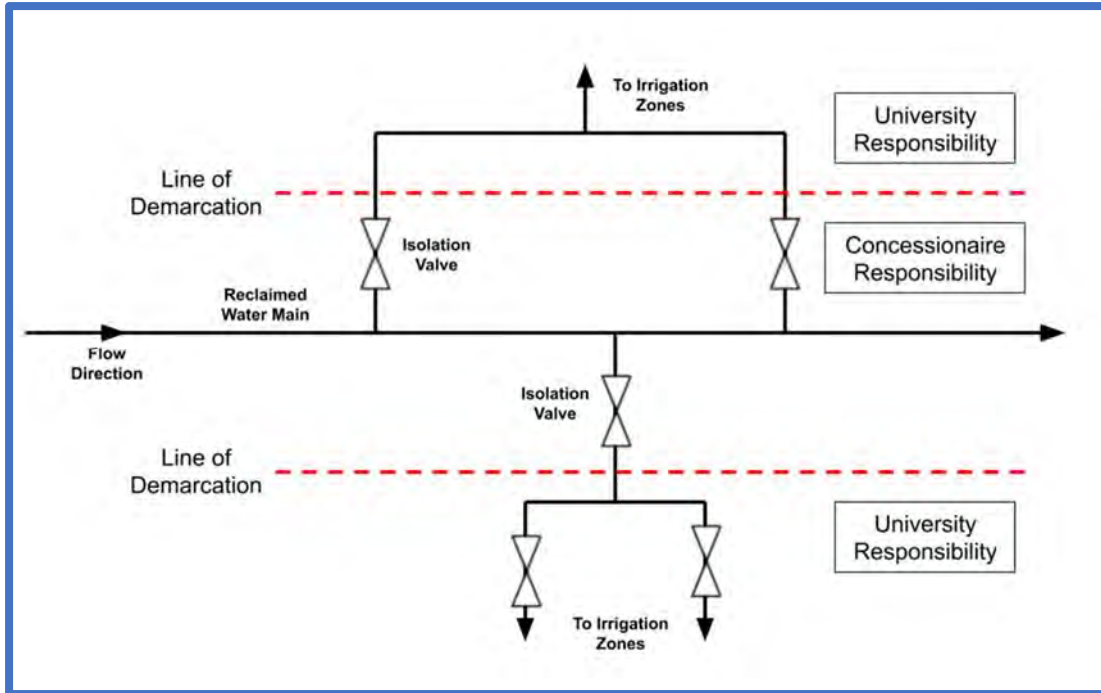

Current Understanding of Lines of Demarcation for Each Utility System

12-4-2023

Electric (Appendix L-1)

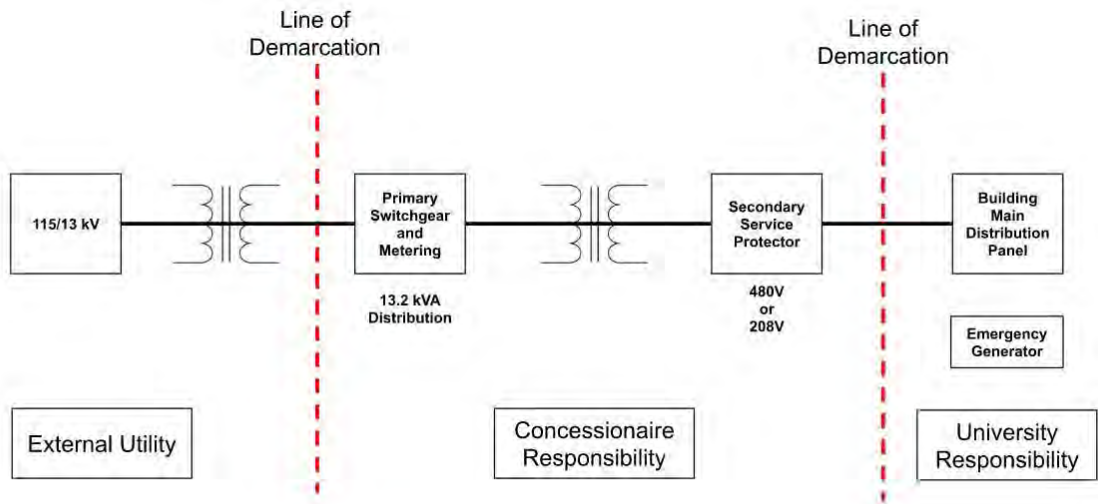

Domestic Water (Appendix L-2)

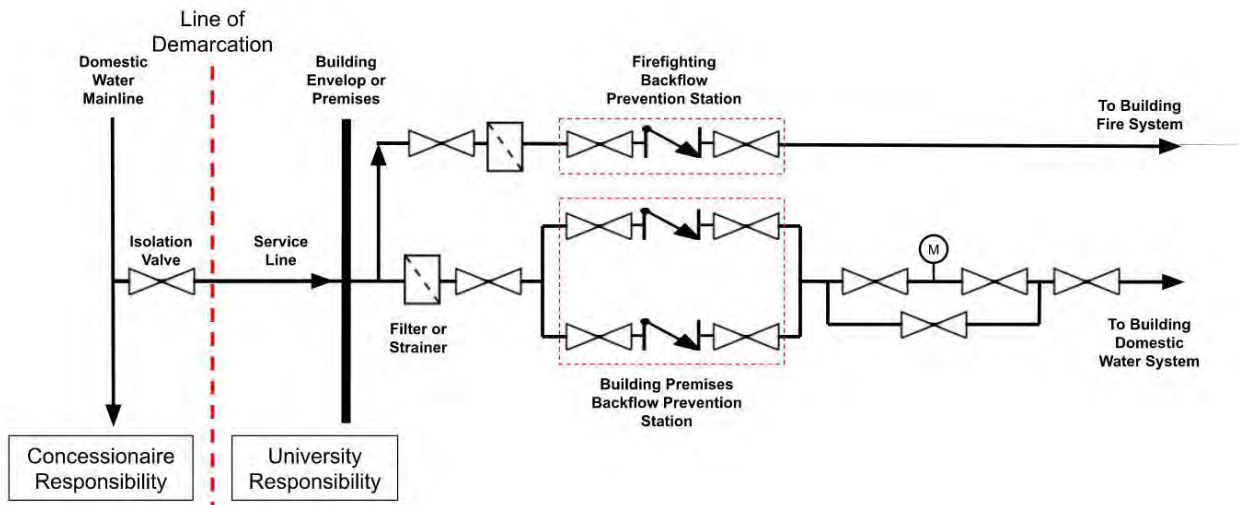

Chilled Water (Appendix L-3)

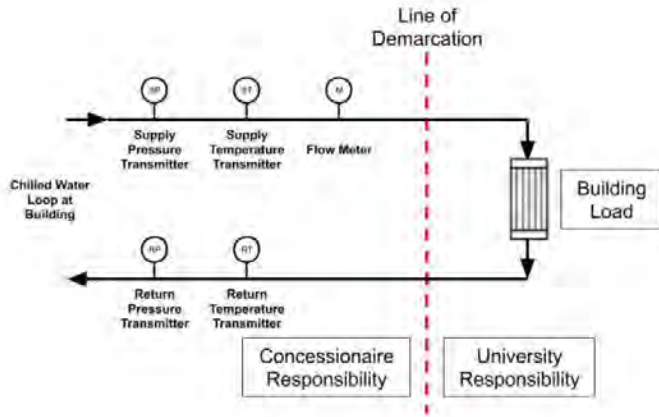

Steam and Condensate (Appendix L-4)

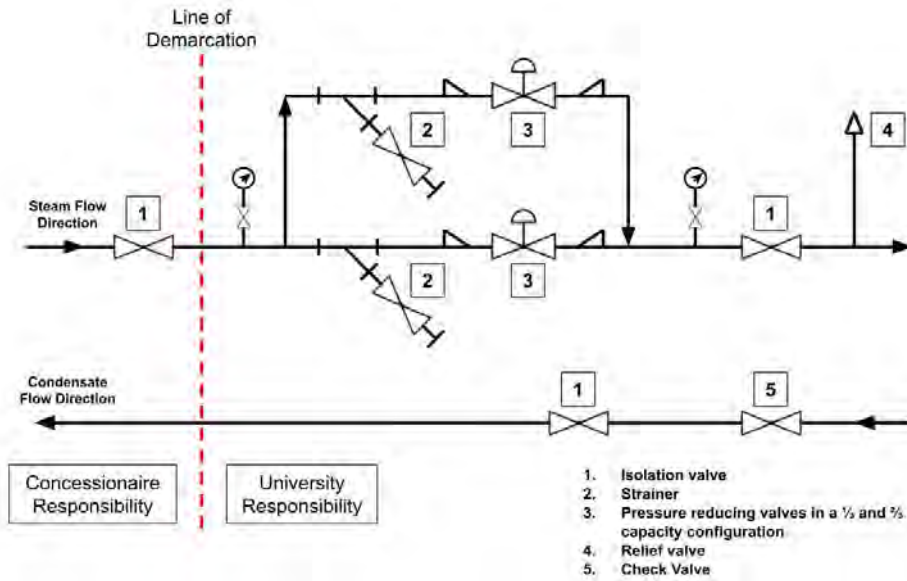

Compressed Air (L-5)

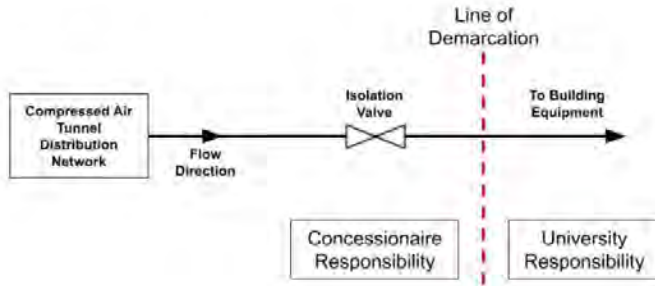

Stormwater (Appendix L-6)

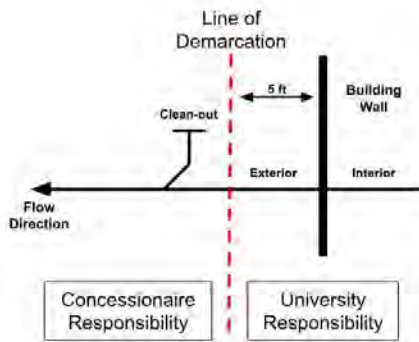

Sanitary Sewer (Appendix L-7)

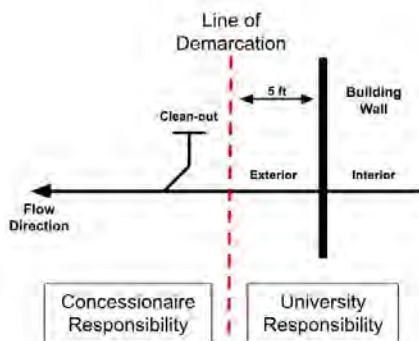

Reclaimed Water (Appendix L-8)

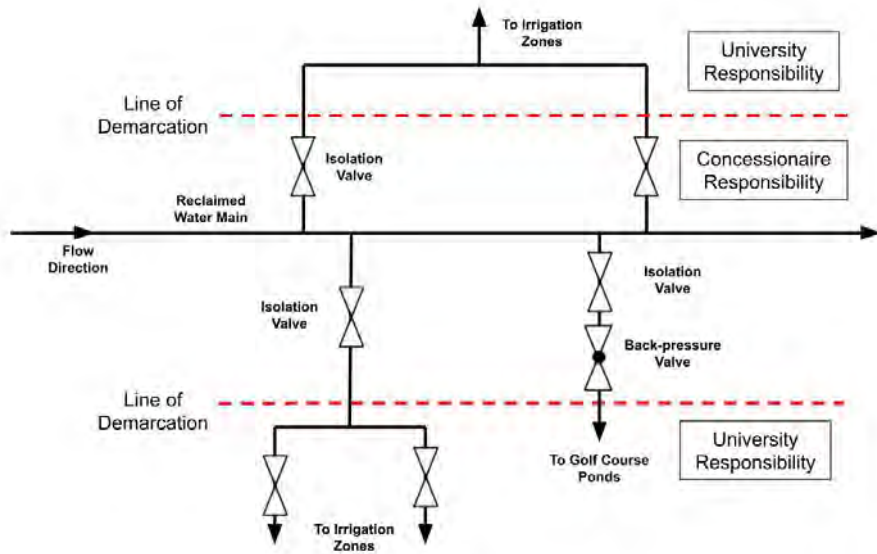

APPENDIX L-9
Reclaimed Line of Demarcation
w/ City of Moscow WWTP

Main Campus Line of Demarcation

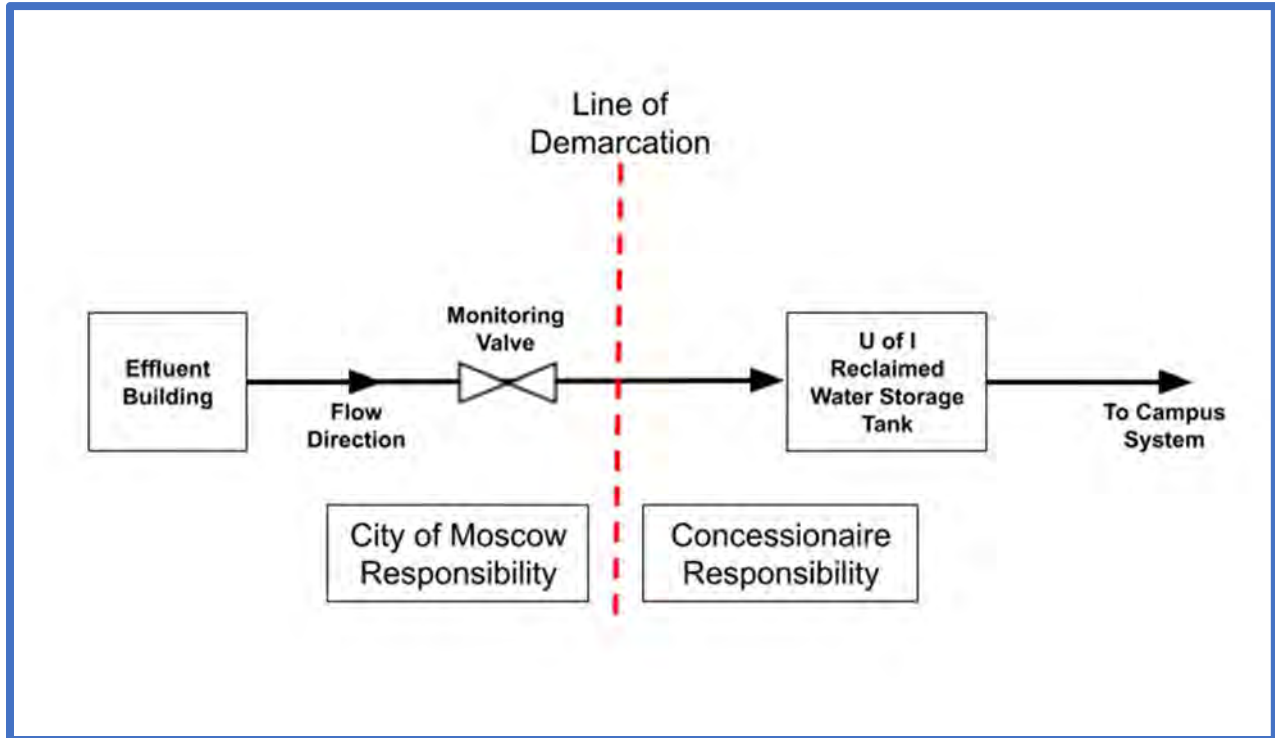

Appendix BB
IT System Responsibility

1. DEFINITIONS

- (A) “Utility Network” means the data infrastructure, network assets and information technology assets for the Utility System owned or leased by the Concessionaire that transmit or store all data gathered by the network devices for the Utility System and transmit all other data and electronic information within the Utility System and all Utility Facilities to data historians, including networking, cabling, devices, meters, virtual servers, firewalls, and software.
- (B) “University Network” means the data infrastructure, network assets and other information technology assets owned or leased by the University that transmit or store data and other electronic information, including networking, cabling, fiber, firewalls, servers, classroom technology, and software.

2. LINE OF DEMARCATION

- (A) The Parties acknowledge that, currently, Utility System Operations utilize the University’s wide area network (“WAN”) and local area network (“LAN”) to support communication between field devices, utility meters, and other virtual and physical sensors that are part of the Utility System. The line of demarcation between the University Network and the Utility Network can either be a physical device with an established point of connection or a separation of roles and responsibilities, in each case, as described in more detail herein and as shown on the representative diagram below as Figure 1: University Network and Utility Network Line of Demarcation. This Appendix BB shall also provide additional information on the roles and responsibilities of the University and the Concessionaire to support Utility System Operations as it relates to the Utility Network.
- (B) Figure 1 below serves as a representative diagram of the line of demarcation between the University and the Concessionaire for the Utility Network infrastructure, which is comprised of both physical and virtual components.
- (C) The University shall be responsible for all operations and maintenance of the University Network, except to the extent of damage caused by the Concessionaire or its Contractors, in which case, the Concessionaire shall promptly repair such damage, at its sole cost and expense. The Concessionaire shall be responsible for all operations and maintenance of the Utility Network, except to the extent of damage caused by the University or its Contractors, in which case, the University shall promptly repair such damage, at its sole cost and expense.

Figure 1: University Network and Utility Network Line of Demarcation

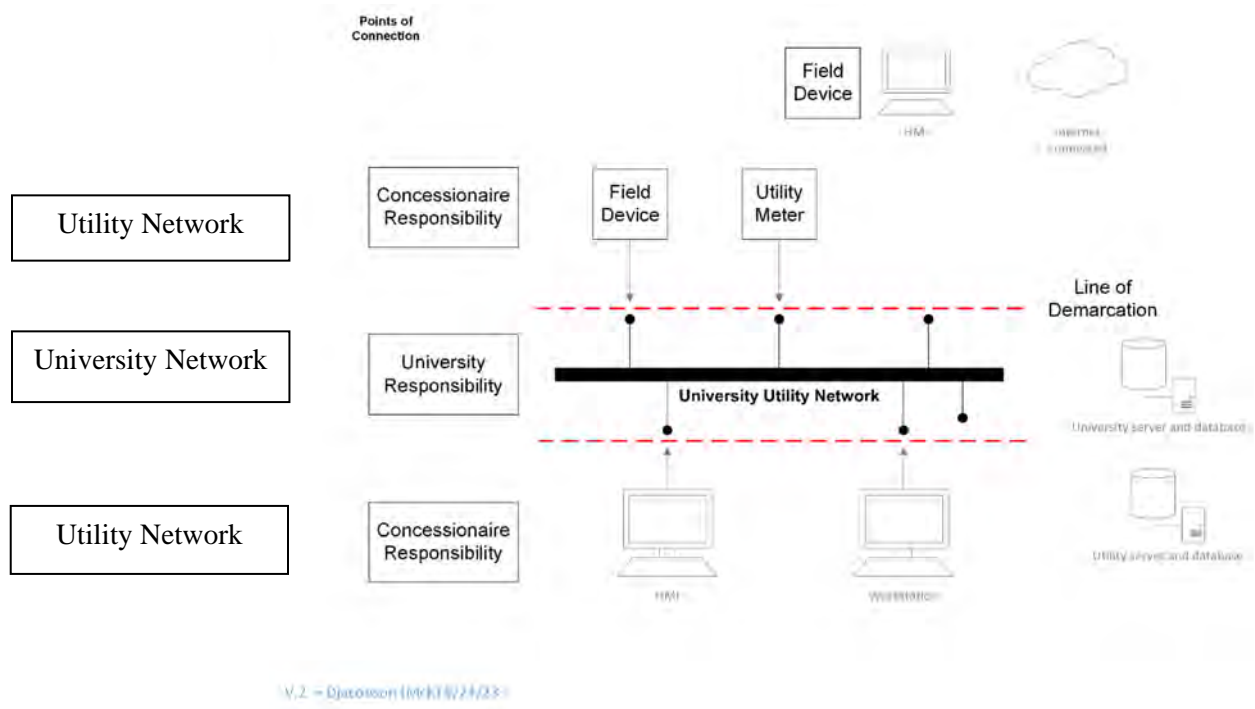

3. SERVICES PROVIDED BY THE UNIVERSITY TO THE CONCESSIONAIRE

The University shall provide to the Concessionaire the following services and access to the following equipment, as applicable, in each case in such location and in such manner as determined by the University in its reasonable discretion, provided that the University shall not materially change the location or manner of any of the listed items in a manner that adversely affects the Utility System Operations and provided further that the Concessionaire shall not use such services or equipment in a manner that causes damage thereto other than the ordinary wear and tear.

- (A) OSI Layer 1 (physical)
 - (i) Copper cable connections between office wall plates and the University’s telecommunications closets, in all buildings where the Concessionaire maintains networked devices
 - (ii) Fiber connections between buildings where the Concessionaire has devices which need network connectivity, and to a University data center
 - (iii) Electrical power for all Utility Network systems
 - (iv) Any other physical component owned by the University that supports the Concessionaire’s Utility System Operations
 - (v) Servers which provide a virtual server environment for the Utility Network
- (B) OSI Layer 2 (data links)

- (i) Network switches for the Utility Network
 - (ii) Wireless access points and associated controllers for the Utility Network
 - (iii) Non-routed virtual local access networks (VLAN) for the Utility Network
 - (iv) Virtual server hosting includes virtual resources including processor, memory and storage for the Utility Network
- (C) OSI Layer 3 (network)
- (i) Assignment of the University's public IP address space for the Utility Network
 - (ii) Internet connectivity with unrestricted bandwidth in connection with the Utility System Operations
 - (iii) Managed connectivity from the Utility Network to the University's network resources (e.g., DHCP, DNS)
 - (iv) Access to virtual server console in connection with the Utility System Operations
 - (v) Remote access service to facilitate the Concessionaire's access to select University services (as determined by the University) on the University Network
- (D) OSI Layer 7 (application)
- (i) Pass-through authentication for wireless authentication on the University Network
 - (ii) Automatic VLAN assignment for wireless clients on the University Campus, of which the Concessionaire may be one
 - (iii) Monitoring and alerting of all University-owned devices and services in the University Network
 - (iv) Provide the Concessionaire's employees with credentials for the purpose of connecting to select University services (as determined by the University) on the University Network

4. SERVICES PROVIDED BY THE CONCESSIONAIRE

In connection with the Utility Services, the Concessionaire shall be responsible for providing the following services and equipment, as applicable as part of its operation of the Utility Network:

- (A) OSI Layer 1 (physical)
- (i) Any physical component owned or leased by the Concessionaire that supports the Concessionaire's operations
- (B) OSI Layer 2 (data links)
- (i) Managed connectivity to the Utility Network resources (e.g., DHCP, DNS)

- (C) OSI Layer 3 (network)
 - (i) Firewall and/or SDWan devices for the Utility Network
 - (ii) Remote access service to facilitate the University's access to select Concessionaire services (as determined by the University) on the Utility Network

- (D) OSI Layer 7 (application), in each case, with respect to the Utility Network
 - (i) Monitoring and alerting
 - (ii) Application access and management
 - (iii) Server administration
 - (iv) Server-based application administration
 - (v) Authentication and authorization for the Concessionaire's wireless network access
 - (vi) CCTV system for general monitoring of Utility System Operations
 - (vii) Provide the University's employees with credentials for the purpose of connecting to select Concessionaire services (as determined by the Concessionaire) on the Utility Network

5. RESPONSIBILITIES OF THE UNIVERSITY

- (A) Service requests regarding the University Network
 - (i) The University will provide the Concessionaire the ability to utilize the University's ticketing system to address service requests with respect to the University Network that affects the Utility Network from the Concessionaire
 - (ii) The University will provide to the Concessionaire direct access to University IT staff for the Concessionaire to escalate IT service requests that materially impact the Utility Network

- (B) Incidents
 - (i) The University will provide the Concessionaire the ability to utilize the University's ticketing system to address incident reports with respect to the University Network resulting from the Utility Network
 - (ii) The University will provide to the Concessionaire direct access to University IT staff for the Concessionaire to escalate IT issues that materially impact the Utility Network

- (C) Operations

- (i) The University shall perform periodic backups of virtual servers used by the Concessionaire in such frequency as determined by the University in compliance with current University policies and standards
- (ii) The University shall provide virtualized host environment security and services solely for Utility System Operations
- (iii) The University shall provide maintenance of network equipment and their configurations that are part of the University Network that interact with the Utility Network
- (iv) The University shall provide maintenance of firewall configurations for the firewall between the Utility Network and the University Network
- (v) The University shall provide continuous monitoring and alerting on critical IT infrastructure that is part of the University Network that impacts the Utility Network
- (vi) The University shall perform data closet network patching and documentation with respect to the University Network that interact with the Utility Network
- (vii) The University shall provide to the Concessionaire escorted access to data closets on such terms and conditions as the University has provided notice in order for the Concessionaire to perform its obligations hereunder

(D) Communications and Coordination

- (i) The University shall maintain a current contact list between the University and the Concessionaire to use for coordination during outages, service interruptions, upgrades or similar incidents, as they relate to the Utility Network or the University Network
- (ii) The University shall proactively communicate with the Concessionaire about any planned outages of the University Network that will impact the Utility Network and the Utility System
- (iii) The University shall provide to the Concessionaire with periodic status updates during and after unplanned outages of the University Network which impact the Utility Network and the Utility System

6. RESPONSIBILITIES OF THE CONCESSIONAIRE

(A) Service requests regarding the Utility Network

- (i) The Concessionaire will use service requests within the University's ticketing system, and the Concessionaire shall submit such service requests to the University using the University's then-current processes for users of the University Network requesting service changes, provided that nothing herein shall obligate the University to approve or implement such changes. Such service requests may include requests to change the following with respect to the University Network: (1) types of services; (2) service levels

provided by the University Network; and (3) physical configuration or equipment of the University Network

- (ii) The Concessionaire will utilize the University's ticketing system to address service requests with respect to the Utility Network that affects the University Network from the University
- (iii) The Concessionaire will provide to the University direct access for the University to escalate IT service requests which materially impact the University Network

(B) Incidents

- (i) The Concessionaire will use the University's ticketing system for reports of incidents impacting the Utility Network, and the Concessionaire shall submit incident reports for service outages, degradation of service, or other extraordinary events relating to the Utility Network to the University using the University's then-current processes for users of the University Network reporting such incidents
- (ii) The Concessionaire will utilize the University's ticketing system to address incident reports with respect to the Utility Network resulting from the University Network
- (iii) The Concessionaire will provide to the University direct access for the University to escalate IT incidents which materially impact the University Network

(C) Operations

- (i) The Concessionaire shall be responsible for its backup requirements and locations for the Utility Network
- (ii) The Concessionaire shall be responsible for data storage locations for the Utility Network
- (iii) The Concessionaire shall perform periodic backups of system configurations, including at any time there is a new configuration or change with respect thereto
- (iv) The Concessionaire shall be responsible for managing the Utility Network server administration, security, access control, remote access, etc.
- (v) The Concessionaire shall provide direct support to the Concessionaire's end users
- (vi) The Concessionaire shall maintain network equipment and their configurations that are part of the Utility Network
- (vii) The Concessionaire shall provide continuous monitoring and alerting on critical IT infrastructure that are part of the Utility Network

(D) Communications and Coordination

- (i) The Concessionaire shall provide the University information regarding the current contact list for the Concessionaire regarding coordination during outages, service interruptions, upgrades, incidents, etc.
- (ii) The Concessionaire will manage communications and response to incidents with the Utility Network

SCHEDULE 5

UTILITY FEE

Calculation of Utility Fee

The Utility Fee for any given Fiscal Year shall be calculated as follows: (i) the Fixed Fee, *plus* (ii) Return on Equity Factor multiplied by 0.4 multiplied by the Variable Fee Component *plus* (iii) Cost of Debt Factor multiplied by 0.6 multiplied by the Variable Fee Component *plus* (iv) the Capital Recovery Amount *plus* (v) the Operating Fee, provided that the Variable Fee Component and Capital Recovery Amount shall be updated at the start of the Fiscal Year Second Half for each Fiscal Year to account for New Approved Capital Improvement Costs incurred in the Fiscal Year First Half and for any Unrecovered Balances becoming \$0.

For the purposes of all calculations hereunder, all dollar amounts will be rounded to the nearest dollar, and all decimals, such as the Cost of Debt Factor and Return on Equity Factor, shall be rounded to the ten-thousandths place.

Notwithstanding anything to the contrary contained herein, costs or expenses may only be included in one component of the Utility Fee for any given period, and the Concessionaire shall not be entitled to double-count such costs or expenses in any one period.

The Parties acknowledge that the purpose of the formula to calculate the Utility Fee is to approximate a reasonable and market rate to be paid by the University for the Utility Services commensurate of what would be paid for such services in the applicable market and is not intended to reflect Concessionaire's actual cost of debt, return on equity, return of capital, tax liability or similar items.

Abandoned Capital Improvements

If any New Approved Capital Improvement Costs were included in the calculation of the Utility Fee in any Fiscal Year for a Capital Improvement that the University subsequently determines, in its reasonable discretion, that the Concessionaire has abandoned and does not ever intend to complete and bring into service for reasons other than a University Directive, a Delay Event, an Adverse Action or any other change in requirements by the University, those New Approved Capital Improvement Costs shall be removed from the Variable Fee Component and the Unrecovered Balance for each ~~such~~ applicable Fiscal Year Half, and the Concessionaire shall promptly after receipt of notice of such determination recalculate the Utility Fee for such Fiscal ~~Years~~ Year resulting from the removal of such New Approved Capital Improvement Costs and pay to the University, within 30 Days of the determination by the Concessionaire, the difference between the Utility Fee actually paid by the University and the Utility Fee that the University would have paid if those New Approved Capital Improvement Costs had not been included.

Exhibit A

Attached hereto as Exhibit A is an illustrative mathematical explanation and example of the Utility Fee formula, which, in the event of a conflict between Exhibit A and such formula, the formula set forth above shall control.

Exhibit B

Attached hereto as Exhibit B is an illustrative mathematical explanation and example of the Capped O&M Index formula and the Uncapped O&M Costs, which, in the event of a conflict between Exhibit B and such formula, the formula set forth in the definition of “Capped O&M Index” and the definition of “Uncapped O&M Costs” shall control.

Definitions

“Capital Improvement Cost” shall mean the lesser of (i) the actual, out-of-pocket costs incurred by the Concessionaire (which costs and expenses shall include payments due and payable by the Concessionaire to the Operator or other Contractors pursuant to an Operating Agreement or similar agreement to the extent disclosed in the Concessionaire’s request for approval of such Capital Improvement pursuant to Article 4 of the Concession Agreement) in bringing a Capital Improvement into service, which may include insurance; and any applicable sales or use tax; ~~incremental financing costs and bonding costs~~ and (ii) the amount budgeted for such Capital Improvement in the University’s Approval therefor (which may include amounts payable to the Operator that are included in such Approval) which shall be increased by any reasonable, actual out-of-pocket costs incurred by the Concessionaire due to a Delay Event that were unavoidable for reasons outside the Concessionaire’s control, but excluding any amount budgeted for non-capital expenses with respect to such Capital Improvement, in each case taking into account any actual or anticipated tax credits or other benefits that will accrue to the Concessionaire (but only as and when such tax credit inures to the benefit of the Concessionaire and in the manner contemplated by the Approval of such Capital Improvement, if contemplated thereby), provided that, upon written request of the Concessionaire, the University shall have the right, in its sole discretion, to increase the Capital Improvement Cost by some or all of the amount that the actual out-of-pocket costs incurred for such Capital Improvement exceeds the amount Approved therefor.

“Capital Recovery Amount” shall mean the sum of the results of the following calculation, calculated separately for each New Approved Capital Improvement: (i) the New Approved Capital Improvement Costs incurred in the immediately prior Fiscal Year Half, *divided by* (ii) the Recovery Period for such New Approved Capital Improvement; which Capital Recovery Amount shall be included in each Fiscal Year’s Utility Fee thereafter until such time as the Unrecovered Balance for such New Approved Capital Improvement Costs equals \$0 (which may occur at the start of a Fiscal Year Second Half); provided that, for the avoidance of doubt the Recovery Period for a New Approved Capital Improvement may extend beyond the Term.

“Capped O&M Ceiling” shall mean 102.0% of the Capped O&M Index for an applicable Fiscal Year.

“Capped O&M Index” shall mean for the applicable Fiscal Year (the “Subject Fiscal Year”) the three-year arithmetic average of Capped O&M Costs for the 3 previous Fiscal Years, regardless of whether the University or the Concessionaire was operating the Utility System (provided that for the Fiscal Years in which the University operated the Utility System, the Capped O&M Costs shall be the costs incurred or accrued by the University that are analogous to the categories of the Capped O&M Costs), provided that (A) when calculating such arithmetic average, the 3 previous Fiscal Years’ of Capped O&M Costs shall each be Adjusted for Inflation as follows: each of the previous Fiscal Years’ Capped O&M Costs shall be multiplied by (I) the CPI Index

in the Subject Fiscal Year *divided by* (II) the CPI Index in such previous Fiscal Year, provided that, in no event, shall the Capped O&M Costs be reduced as a result of being Adjusted for Inflation and (B) for purposes of calculating the Capped O&M Costs to be part of the three-year arithmetic average of Capped O&M Costs for the Capped O&M Index in a Subject Fiscal Year, the Capped O&M Costs for any Fiscal Year used in such calculation shall not exceed the Capped O&M Ceiling for that Fiscal Year, except that the University may, in its sole discretion, approve the inclusion of any Capped O&M Costs above the Capped O&M Ceiling in such calculation. Notwithstanding the foregoing, costs identified in the definition of “Capped O&M Costs” (i) related to (1) a New Approved Capital Improvement after it has been brought into service or (2) an Ongoing Utility System Project after it has been transferred to the Concessionaire and becomes part of the Utility System, (ii) related to operations and maintenance that are reasonably necessary to cause the Utility System or Utility System Operations to comply with the enactment of a new Law or the modification, amendment or change in enforcement or interpretation of a Law (including a change in the application or implementation thereof by any Governmental Authority) arising after the Setting Date or (iii) for any other adjustments to the Capped O&M Index made pursuant to the Agreement (including pursuant to Section 2.5(d), Section 2.5(k), Section 3.23, Section 5.1 and Section 6.3(a)) shall not be included in the calculation of the Capped O&M Index in each case, for the first 3 Fiscal Years (and any partial Fiscal Year) after the applicable occurrence (the “O&M Test Period”) as, for the avoidance of doubt, they will have been included as “Uncapped O&M Costs” pursuant to subclauses (p), (q) and (r) of the definition thereof for the applicable O&M Test Period. After the O&M Test Period elapses for each such occurrence, those costs that would otherwise be Capped O&M Costs but for the immediately prior sentence shall thereafter be included in the calculation of the Capped O&M Index and they shall be applied to increase the Capped O&M Index and the calculation of the historic Capped O&M Costs for each full Fiscal Year within the applicable O&M Test Period solely for the purpose of calculating the Capped O&M Index for the Fiscal Year immediately after such O&M Test Period and the subsequent two Fiscal Years. Notwithstanding the foregoing, the University and the Concessionaire hereby acknowledge and agree that, for purposes of calculating the Capped O&M Index, the Capped O&M Costs for the Fiscal Years ending June 30, 2018, June 30, 2019 and June 30, 2020 are deemed to be \$2,635,157.74, \$2,714,772.30 and \$3,182,966.81, respectively, which, for the avoidance of doubt, shall be Adjusted for Inflation in accordance with this definition of “Capped O&M Index”. For the further avoidance of doubt, to determine the CPI Index for a Fiscal Year hereunder, the Parties shall calculate the arithmetic average of the monthly CPI Index for each month during such Fiscal Year and such average shall be the CPI Index for that Fiscal Year.

“Cost of Debt Factor” shall be .0230, which shall be adjusted at the end of each fifth Fiscal Year (starting on June 30, 2026), to be the “yield-to-worst”, expressed as a decimal, as such term is defined in the Barclays Baa U.S. Corporate Investment Grade Index using the “LCB1YW” ticker as of the date hereof (or if such index is no longer published, such other index as reasonably agreed by the Concessionaire and the University), which adjustment shall not be considered an amendment or modification of this Schedule 5 or the method of calculation of the Utility Fee and shall not require the approval of either the Concessionaire or the University. The Concessionaire shall have the right, with the University’s Approval which may be withheld in its sole discretion, to set the Cost of Debt Factor for a portion of the Variable Fee Component attributable to the Unrecovered Balance of a New Approved Capital Improvement based on the

actual cost of debt incurred by the Concessionaire with respect to such New Approved Capital Improvement.

“Fixed Fee” shall mean \$7,600,000, increased by 1.5% to \$7,714,000 on July 1, 2026 for the Fiscal Year ending on June 30, 2027 and by 1.5% at the start of each Fiscal Year thereafter. For the avoidance of doubt, the Fixed Fee is compensation for (i) the Concessionaire performing the Utility Services as set forth in the Agreement, (ii) the risks and liabilities undertaken by the Concessionaire in the Agreement for which the Concessionaire may not otherwise be compensated under the Agreement and (iii) the expertise and technical know-how that the Concessionaire is expected to bring to bear on the Utility System and the Utility System Operations.

“New Approved Capital Improvement” shall mean a Capital Improvement that was, or is being, constructed by the Concessionaire and is or will be brought into service as part of the Utility System.

“New Approved Capital Improvement Cost” shall mean the Capital Improvement Cost of a New Approved Capital Improvement.

“Operating Fee” shall mean the sum of (i) the Capped O&M Index, as may be adjusted in accordance with the definition thereof, (ii) the Annual Savings Incentive and (iii) the Uncapped O&M Costs.

“Relevant Region” shall mean Idaho, Montana, Nevada, Oregon, Utah, Washington and Wyoming.

“Return on Equity Factor” shall mean .0966, which shall be adjusted at the end of each ~~5th~~^{5th}~~fourth~~^{fifth} Fiscal Year (starting on June 30, 2026) to be the mean average of all return on equity percentages (as expressed as a decimal) for the investor-owned electric, gas or water public utilities in the Relevant Region approved within the previous 10 Fiscal Years, to the extent approved by a publicly-available, final, non-appealable order (or its equivalent) issued by the relevant public utilities commission or court of competent jurisdiction, which shall be determined (a) with respect to electric and gas public utilities, using the *CapitalIQ Market Intelligence* platform, or if such platform no longer exists, a replacement platform as determined by the University, acting reasonably, based on the following search terms: (i) peer set based on regulated electric, natural gas, and water utilities in the Relevant Region and (ii) regulatory rate case filings; mean of the approved cases within the last 10 years and (b) with respect to water public utilities, using the information published by the applicable commissions within the Relevant Region. For the avoidance of doubt, the foregoing adjustment shall not be considered an amendment or modification of this Schedule 5 or the method of calculation of the Utility Fee and shall not require the approval of either the Concessionaire or the University.

“Unrecovered Balance” shall mean for the New Approved Capital Improvement Costs incurred in any prior Fiscal Year Half, an amount equal to (i) those New Approved Capital Improvement Costs in such Fiscal Year Half less (ii) the aggregate Capital Recovery Amount that has been

paid in the calculation of the Utility Fee in prior Fiscal ~~Years~~Year Halves that are attributable to such New Approved Capital Improvement Costs.

“Variable Fee Component” shall mean the sum of all Unrecovered Balances~~—~~
, provided that, for the avoidance of doubt, the Variable Fee Component shall be recalculated for each Fiscal Year Half as a result of changes to the Unrecovered Balance for each Fiscal Year Half.

Exhibit A

CALCULATION OF UTILITY FEE

Formula

$$UF = FF + (ROE \times 0.4 \times VFC) + (COD \times 0.6 \times VFC) + CRA + OF$$

COD = Cost of Debt Factor

CRA = Capital Recovery Amount

FF = Fixed Fee

OF = Capped O&M Index + Annual Savings Incentive + Uncapped O&M Costs

ROE = Return on Equity Factor

UF = Utility Fee

VFC = Variable Fee Component

Exemplar

As an exemplar only to illustrate a portion of the calculation of the Utility Fee, below shows the calculation for clauses (ii) and (iii) of the Utility Fee formula and the Capital Recovery Amount for Fiscal Years 2021, 2022 and 2023, assuming that (a) \$1,000,000 is incurred as a New Approved Capital Improvement Cost in Fiscal Year 2020 for a New Approved Capital Improvement with an Recovery Period of 20 years with no further New Approved Capital Improvement Costs in 2021, 2022 and 2023, (b) the Return on Equity Factor is 0.10 and (c) the Cost of Debt Factor is 0.04. For the avoidance of doubt, none of these assumptions shall be binding on the University or the Concessionaire, and they are not intended to reflect any expectations of either Party or the actual calculation of the Utility Fee.

Fiscal Year 2020

Utility Fee clause (ii) = \$0, calculated as follows: $0.1 \times 0.4 \times \$0$

Utility Fee clause (iii) = \$0, calculated as follows: $0.04 \times 0.6 \times \$0$

Capital Recovery Amount = \$0

Fiscal Year 2021

Utility Fee clause (ii) = \$40,000, calculated as follows: $0.1 \times 0.4 \times (\$1,000,000 - \$0)$

Utility Fee clause (iii) = \$24,000, calculated as follows: $0.04 \times 0.6 \times (\$1,000,000 - \$0)$

Capital Recovery Amount = \$50,000, calculated as follows: $\$1,000,000 / 20$

Fiscal Year 2022

Utility Fee clause (ii) = \$38,000, calculated as follows: $0.1 \times 0.4 \times (\$1,000,000 - \$50,000)$

Utility Fee clause (iii) = \$22,800, calculated as follows: $0.04 \times 0.6 \times (\$1,000,000 - \$50,000)$

Capital Recovery Amount = \$50,000, calculated as follows: $\$1,000,000 / 20$

As an exemplar only to illustrate the calculation of the Baseline Capped O&M Costs and thereby the Annual Savings Incentive sub-component of the Operating Fee component of the Utility Fee for Fiscal Year 2023, assuming that:

- (a) Capped O&M Index is \$10,000,000 for Fiscal Year 2021 (the first full Fiscal Year),
- (b) CPI Index is 1.022 in Fiscal Year 2022 and 1.023 in Fiscal Year 2023, and
- (c) forecasted annual operations and maintenance costs attributable to all Approved Capital Improvements and Material Changes is \$50,000 in 2023, and
- (d) actual Capped O&M Index is \$9,550,000 for Fiscal Year 2023,

then:

Baseline Capped O&M Costs = \$10,505,060 calculated as follows: $\$10,000,000 \times 1.022 \times 1.023 + \$50,000$

Total savings = \$955,060 calculated as follows: $\$10,505,060 - \$9,550,000$
Annual Savings Incentive = \$477,530, calculated as follows: $\$955,060 \times 0.5$

Exhibit B

CAPPED O&M INDEX CALCULATION

Formula

COMI = 3Y O&M Average

UOMC = OUOMC + NACI O&M + OUSP O&M + NL O&M + OA O&M

COMI = Capped O&M Index

3Y O&M Average = three-year arithmetic average of Capped O&M Costs for last 3 previous Fiscal Years as adjusted by clauses A & B of the COMI definition.

OUOMC = Uncapped O&M Costs other than NACI O&M, OUSP O&M, NL O&M or OA O&M

NACI O&M = annual operations and maintenance costs for New Approved Capital Improvements in the applicable O&M Test Period.

OUSP O&M = annual operations and maintenance costs for Ongoing Utility System Projects in the applicable O&M Test Period.

NL O&M = forecasted annual operations and maintenance costs for compliance with new Laws in the applicable O&M Test Period.

OA O&M = other adjustments to the COMI permitted by the Agreement in the applicable O&M Test Period.

Exemplar

As an exemplar only to illustrate the portion of the calculation of the Utility Fee related to the calculation of the Capped O&M Index and Uncapped O&M Costs for 2024, set forth below is the calculation of the Operating Fee using the hypothetical amounts set forth in the table below. For avoidance of doubt, none of these assumptions shall be binding on the University or the Concessionaire, and they are not intended to reflect any expectations of either Party as to the actual calculation of the Capped O&M Index or Uncapped O&M Costs.

Year	CPI	COMI	COM Costs	NACI O&M	OUSP O&M	NL O&M	OA O&M	OUOMC
2021	260	2.1 MM	2.11 MM	0	0	0	0	0
2022	280	2.15 MM	2.3 MM	.02 MM ¹	.03 MM ¹	.025 MM ¹	.01 MM ¹	0
2023	310	2.26 MM	2.12 MM	.02 MM ¹	.03 MM ¹	.025 MM ¹	.01 MM ¹	.01 MM
2024	290	2.245 MM		.02 MM ¹	.03 MM ¹	.025 MM ¹	.01 MM ¹	.01 MM

For Example, the 3Y O&M Average For Subject Fiscal Year of 2023 would be calculated as follows:

((2024 CPI / 2021 CPI, but no less than 1) * 2021 Capped O&M Costs, but the 2021 Capped O&M Costs can be no more than 102% of 2021 COMI, *plus* (2024 CPI / 2022 CPI, but no less than 1) * 2022 Capped O&M Costs, but the 2022 Capped O&M Costs can be no more than 102% of 2022 COMI, *plus* (2024 CPI / 2023 CPI, but no less than 1) * 2023 Capped O&M Costs, but the 2023 Capped O&M Costs can be no more than 102% of 2023 COMI) / 3

$$((290 / 260 = 1.11 * 2.11 = \$2.342 \text{ MM}) + (290 / 280 = 1.036 * 2.193 \text{ (limited by 1.02 of COMI)} = \$2.272) + (290 / 310 \text{ (can't be less than 1)} = 1 * 2.12 = \$2.12 \text{ MM})) / 3 = \$2.245 \text{ MM}$$

$$\$2,245,000 \text{ COMI} + \$20,000 \text{ NACI O\&M} + \$30,000 \text{ OUSP O\&M} + \$25,000 \text{ NL O\&M} + 10,000 \text{ OA O\&M} + \$10,000 \text{ OUOMC} = \$2,340,000$$

¹ Such amounts would be included in the Capped O&M Index for Fiscal Years 2022, 2023 and 2024 (as adjusted by the CPI Index) solely for the purpose of calculating the Capped O&M Index for Fiscal Years 2025, 2026 and 2027, as applicable.

Summary report:	
Litera Compare for Word 11.6.0.100 Document comparison done on 12/21/2023 5:36:39 PM	
Style name: JD Color With Moves	
Intelligent Table Comparison: Inactive	
Original DMS: iw://NAI/NAI/1538223303/1	
Modified DMS: iw://NAI/NAI/1538223303/3	
Changes:	
<u>Add</u>	14
Delete	11
Move From	0
<u>Move To</u>	0
<u>Table Insert</u>	0
Table Delete	0
<u>Table moves to</u>	0
Table moves from	0
Embedded Graphics (Visio, ChemDraw, Images etc.)	0
Embedded Excel	0
Format changes	0
Total Changes:	25

AMENDED AND RESTATED SCHEDULE 15

KEY PERFORMANCE INDICATORS

The Concessionaire shall calculate whether any KPI Compensation for each Key Performance Indicator has been generated during a Fiscal Year in accordance with this Schedule 15. For the avoidance of doubt, each KPI Calculation corresponds to one Key Performance Indicator.

1. Definitions

- (a) Unless otherwise specified or the context otherwise requires, for the purposes of this Schedule 15, the following terms have the following meanings:
- (i) “Availability KPIs” means those Key Performance Indicators which are measured by the following KPI Calculations: Electric Hours KPI Calculation, Electric Events KPI Calculation, ~~Steam Plant Hours KPI Calculation, Steam Plant Events KPI Calculation,~~ General Steam Hours KPI Calculation, General Steam Events KPI Calculation, ~~Chilled Water Tank Hours KPI Calculation, Chilled Water Tank Events KPI Calculation,~~ General Chilled Water Hours KPI Calculation, General Chilled Water Events KPI Calculation, Domestic Water Hours KPI Calculation, Domestic Water Event KPI Calculation, Sanitary Sewer Hours KPI Calculation, Sanitary Sewer Events KPI Calculation, Storm Water Hours KPI Calculation, Storm Water Events KPI Calculation, Reclaimed Water Hours KPI Calculation, Reclaimed Water Event KPI Calculation, Compressed Air Hours KPI Calculation, Compressed Air Event KPI Calculation.
 - (ii) “Compressed Air Portion of the Utility System” means that portion of the Utility System exclusively used in the production and distribution of compressed air to the University Campus to the line of demarcation for the Compressed Air System as described in the Performance Standards.
 - (iii) “Criticality Factor” means the factor for each University Building, as reasonably determined by the University as set forth on Appendix 24, which may, in no event, exceed 1.0.
 - (~~iii~~iv) “Domestic Water Portion of the Utility System” means that portion of the Utility System exclusively used in the production and distribution of potable water (and fire protection) to the University Campus to the line of demarcation for the Domestic Water System as described in the Performance Standards.
 - (~~iv~~v) “Electric Portion of the Utility System” means that portion of the Utility System exclusively used in the distribution of electricity to the University Campus to the line of demarcation for the Electric System as described in the Performance Standards.

- (vi) “Equivalent Outage Hours” means, for each Unplanned Outage for each Portion of the Utility System, the product of the number of hours that such Unplanned Outage lasted (rounded up to the next full hour), multiplied by the Criticality Factor for the University Building affected by that Unplanned Outage for that Portion of the Utility System.
- (~~vii~~) “General Chilled Water Portion of the Utility System” means that portion of the Utility System, ~~other than the Chilled Water Tank (Thermal Energy Storage),~~ exclusively used in the production and distribution of chilled water to the University Campus to the line of demarcation for the Chilled Water System as described in the Performance Standards.
- (~~viii~~) “General Steam Portion of the Utility System” means that portion of the Utility System, ~~other than the Steam Plant,~~ exclusively used in the production and distribution of steam to the University Campus to the line of demarcation for the Steam and Condensate System as described in the Performance Standards.
- (~~ix~~) “KPI Calculation Appendix” means each of the appendices attached to this Schedule 15.
- (~~x~~) “KPI Calculations” means, collectively, all Availability KPIs and all Operational KPIs, and “KPI Calculation” shall mean any one of the foregoing.
- (~~xi~~) “KPI Event” occurs when a KPI Calculation does not meet the Target for the applicable Key Performance Indicator in a Fiscal Year.
- (~~xii~~) “KPI Event Year” means a Fiscal Year in which a KPI Event occurs.
- (~~xiii~~) “KPI Measurement Window” means, commencing with the then-current Fiscal Year, the number of consecutive Fiscal Years preceding that Fiscal Year including the current Fiscal Year (but in no event more than the number of “Consecutive Event Years” shown on the applicable KPI Calculation Appendix) in which such KPI Event occurred.
- (~~xiv~~) measured by the following KPI Calculations: Safety KPI, Environmental Compliance KPI and the Public Notice of Water Quality KPI.
- (~~xv~~) of the Utility System, ~~the Chilled Water Tank (Thermal Energy Storage),~~ the Compressed Air Portion of the Utility System, the Domestic Water Portion of the Utility System, the Electric Portion of the Utility System, the Reclaimed Water Portion of the Utility System, the Sanitary Sewer Portion of the Utility System, the General Steam Portion of the Utility

System, ~~the Steam Plant~~, or the Storm Water Portion of the Utility System, as applicable.

- (~~xiv~~xvi) “Reclaimed Water Portion of the Utility System” means that portion of the Utility System exclusively used in the process and delivery of reclaimed, non-potable water to the University Campus to the line of demarcation for the Reclaimed Water System as described in the Performance Standards.
- (~~xv~~xvii) “Sanitary Sewer Portion of the Utility System” means that portion of the Utility System exclusively used for sanitary sewer purposes serving the University Campus up to the line of demarcation for the Sanitary Sewer System as described in the Performance Standards.
- (~~xvi~~) “~~Steam Plant~~” means ~~the portion of the Energy Plant that is used in the production and distribution of steam to the exterior of the walls of such district energy plant, which is then distributed to the University Campus through the General Steam Portion of the Utility System; provided that, for the avoidance of doubt the “Steam Plant” does not include the portions of such district energy plant that are used in the production or distribution of other Utilities beside steam.~~
- (~~xvii~~xviii) “Storm Water Portion of the Utility System” means that portion of the Utility System exclusively used for storm water purposes serving the University Campus up to the line of demarcation for the Storm Water System as described in the Performance Standards.
- (~~xviii~~xix) “Target” for any Key Performance Indicator means the amount or percentage, as applicable, for that Key Performance Indicator as identified on the relevant KPI Calculation Appendix.
- (xx) “Total Possible Connection Hours” shall be calculated as the total operating hours for a given utility system in the year. For all systems other than the Reclaimed Water System, this is: $24 \text{ hours/day} \times 365 \text{ days/year} = 8,760 \text{ Total Possible Connection Hours (“TPCH”)}$. For the Reclaimed Water System, there are $24 \text{ hours/day} \times 184 \text{ days/year} = 4,416 \text{ TPCH}$.
- (xxi) “University Building” means each building or improvement connected to a Portion of the Utility System, which, as of the original Closing Date, is the list set forth on Appendix 24. A building or improvement shall be considered a University Building even if it is not listed on Appendix 24 or any update thereto.

- (b) All capitalized words, not otherwise defined herein, shall have the meaning set forth in this Agreement (including all other schedules thereto), and if, pursuant to the terms and conditions of the Agreement, the definition of such capitalized

words is modified, such modification shall be deemed to apply in this Schedule 15.

- (c) References to a “current Fiscal Year” herein shall mean the Fiscal Year for which the KPI Calculation is being determined.

2. *Rules of General Applicability*

- (a) If, in any instance, the KPI Compensation is shown by the applicable KPI Calculation Appendix to be \$1,000,000, it (and any cell in that KPI Calculation Appendix to the right or below such cell) shall be deemed to read, in all such instances, “the greater of (i) \$1,000,000 and (ii) 10% of the Utility Fee for that particular Fiscal Year.”

- (b) If, in any instance, the KPI Compensation is shown by the applicable KPI Calculation Appendix to be \$500,000, it (and any cell in that KPI Calculation Appendix to the right or below such cell) shall be deemed to read, in all such instances, “the greater of (i) \$500,000 and (ii) 5% of the Utility Fee for that particular Fiscal Year.”

- ~~(e) If there is an Unplanned Outage that affects both the Chilled Water Tank (Thermal Energy Storage) and the General Chilled Water Portion of the Utility System, such Unplanned Outage shall be considered an Unplanned Outage for both the Chilled Water Tank (Thermal Energy Storage) and the General Chilled Water Portion of the Utility System. If there is an Unplanned Outage that affects both the Steam Plant and the General Steam Portion of the Utility System, such Unplanned Outage shall be considered an Unplanned Outage for both the Steam Plant and the General Steam Portion of the Utility System.~~

- ~~(d)~~ All amounts shown in the KPI Calculation Appendix shall be Adjusted for Inflation on the date that is the start of each Compensation Calculation Measuring Period other than the first such Compensation Calculation Measuring Period.

- (d) The University shall have the right, upon notice to the Concessionaire, to revise Appendix 24 to amend the list of University Buildings and the Criticality Factor of any University Building in the event of an addition or removal of a University Building from the Utility System and/or a change in function, use or need for such University Building or for such other reason as determined by the University in good faith. If the University fails to provide notice revising Appendix 24 when a University Building is added to the Utility System, including any Portion of the Utility System, it shall automatically be deemed to have a Criticality Factor of 1.0 until such time as the University provides notice thereof.

- (e) The Parties acknowledge and agree that this Schedule 15, the Criticality Factors, and the KPI Calculation Appendices appended hereto shall govern from and after the original Closing Date and that Schedule 15 to the Original Agreement shall no longer be of any force or effect for any time period.

3. *KPI Calculation for each Availability KPI*

- (a) *KPI Calculation for Electricity – Unplanned Outage (Hours): KPI Calculation Appendix 1*

The Key Performance Indicator for the hours of Unplanned Outages for electricity is determined on an annual basis in each Fiscal Year by ~~dividing the number of hours that constitute an Unplanned Outage in that Fiscal Year~~ aggregating the Equivalent Outage Hours for the Electric Portion of the Utility System ~~by the total possible connection hours of the Electric Portion of the Utility System during that Fiscal Year, expressed as a percentage rounded to the nearest thousandth decimal point, and subtracting that result from 100%~~ (the “Electric Hours KPI Calculation”), provided that if one Unplanned Outage event affects multiple University Buildings for the Electric Portion of the Utility System, then the Electric Hours KPI Calculation shall only include the Equivalent Outage Hours for one University Building, which will be the highest Equivalent Outage Hours for one University Building for that Unplanned Outage.

- (b) *KPI Calculation for Electricity – Unplanned Outage (Events): KPI Calculation Appendix 2*

The Key Performance Indicator for the number of events of Unplanned Outages for electricity is determined on an annual basis in each Fiscal Year to equal the number of unique Unplanned Outages for the Electric Portion of the Utility System or any portion thereof (the “Electric Events KPI Calculation”).

- (c) *KPI Calculation for Steam ~~Plant~~ (General) – Unplanned Outage (Hours): KPI Calculation Appendix ~~3~~ 5*

~~The Key Performance Indicator for the hours of Unplanned Outages for the Steam Plant is determined on an annual basis in each Fiscal Year by dividing the number of hours that constitute an Unplanned Outage in that Fiscal Year for the Steam Plant by the total possible connection hours of the Steam Plant during that Fiscal Year, expressed as a percentage rounded to the nearest thousandth decimal point, and subtracting that result from 100% (the “Steam Plant Hours KPI Calculation”)~~

- (d) *~~KPI Calculation for Steam Plant – Unplanned Outage (Events): KPI Calculation Appendix 4~~*

~~The Key Performance Indicator for the number of events of Unplanned Outages for the Steam Plant is determined on an annual basis in each Fiscal Year to equal the number of unique Unplanned Outages for the Steam Plant or any portion thereof (the “Steam Plant Events KPI Calculation”)~~

- (e) *~~KPI Calculation for Steam (General) – Unplanned Outage (Hours): KPI Calculation Appendix 5~~*

The Key Performance Indicator for the hours of Unplanned Outages for steam, ~~other than in connection with the Steam Plant,~~ is determined on an annual basis in each Fiscal Year by ~~dividing the number of hours that constitute an Unplanned Outage in that Fiscal Year for the General~~ aggregating the Equivalent Outage Hours for the Steam Portion of the Utility System ~~by the total possible connection hours of the General Steam Portion of the Utility System during that Fiscal Year,~~ expressed as a percentage rounded to the nearest thousandth decimal point, and subtracting that result from 100% (the “General Steam Hours KPI Calculation”); provided that if one Unplanned Outage event affects multiple University Buildings for the Steam Portion of the Utility System, then the General Steam Hours KPI Calculation shall only include the Equivalent Outage Hours for one University Building, which will be the highest Equivalent Outage Hours for one University Building for that Unplanned Outage.

- (~~f~~d) *KPI Calculation for Steam (General) – Unplanned Outage (Events): KPI Calculation Appendix 6*

The Key Performance Indicator for the number of events of Unplanned Outages for steam, ~~other than in connection with the Steam Plant,~~ is determined on an annual basis in each Fiscal Year to equal the number of unique Unplanned Outages for the General Steam Portion of the Utility System or any portion thereof (the “General Steam Events KPI Calculation”).

- (~~g~~e) *KPI Calculation for Chilled Water ~~Tank (Thermal Energy Storage)~~ (General) – Unplanned Outage (Hours): KPI Calculation Appendix 7~~9~~*

~~The Key Performance Indicator for the hours of Unplanned Outages for the Chilled Water Tank (Thermal Energy Storage) is determined on an annual basis in each Fiscal Year by dividing the number of hours that constitute an Unplanned Outage in that Fiscal Year for the Chilled Water Tank (Thermal Energy Storage) by the total possible connection hours of the Chilled Water Tank (Thermal Energy Storage) during that Fiscal Year, expressed as a percentage rounded to the nearest thousandth decimal point, and subtracting that result from 100% (the “Chilled Water Tank Hours KPI Calculation”).~~

- (~~h~~) *KPI Calculation for Chilled Water Tank (Thermal Energy Storage) – Unplanned Outage (Events): KPI Calculation Appendix 8*

~~The Key Performance Indicator for the number of events of Unplanned Outages for the Chilled Water Tank (Thermal Energy Storage) is determined on an annual basis in each Fiscal Year to equal the number of unique Unplanned Outages for the Chilled Water Tank (Thermal Energy Storage) or any portion thereof (the “Chilled Water Tank Events KPI Calculation”).~~

- (~~i~~) *KPI Calculation for Chilled Water (General) – Unplanned Outage (Hours): KPI Calculation Appendix 9*

The Key Performance Indicator for the hours of Unplanned Outages for chilled water, ~~other than in connection with the Chilled Water Tank (Thermal Energy Storage),~~ is determined on an annual basis in each Fiscal Year by ~~dividing the number of hours that constitute an Unplanned Outage in that Fiscal Year for the General~~ aggregating the Equivalent Outage Hours for the Chilled Water Portion of the Utility System ~~by the total possible connection hours of the General Chilled Water Portion of the Utility System during that Fiscal Year, expressed as a percentage rounded to the nearest thousandth decimal point, and subtracting that result from 100%-(the “General Chilled Water Hours KPI Calculation”)-,~~ provided that if one Unplanned Outage event affects multiple University Buildings for the Chilled Water Portion of the Utility System, then the General Chilled Water Hours KPI Calculation shall only include the Equivalent Outage Hours for one University Building, which will be the highest Equivalent Outage Hours for one University Building for that Unplanned Outage.

- (jf) *KPI Calculation for Chilled Water (General) – Unplanned Outage (Events): KPI Calculation Appendix 10*

The Key Performance Indicator for the number of events of Unplanned Outages for chilled water, ~~other than in connection with the Chilled Water Tank (Thermal Energy Storage),~~ is determined on an annual basis in each Fiscal Year to equal the number of unique Unplanned Outages for the General Chilled Water Portion of the Utility System or any portion thereof (the “General Chilled Water Events KPI Calculation”).

- (kg) *KPI Calculation for Domestic Water – Unplanned Outage (Hours): KPI Calculation Appendix 11*

The Key Performance Indicator for the hours of Unplanned Outages for domestic water (including potable and fire protection) is determined on an annual basis in each Fiscal Year by ~~dividing the number of hours that constitute an Unplanned Outage in that Fiscal Year~~ aggregating the Equivalent Outage Hours for the Domestic Water Portion of the Utility System ~~by the total possible connection hours of the Domestic Water Portion of the Utility System during that Fiscal Year, expressed as a percentage rounded to the nearest thousandth decimal point, and subtracting that result from 100%-(the “Domestic Water Hours KPI Calculation”)-,~~ provided that if one Unplanned Outage event affects multiple University Buildings for the Domestic Water Portion of the Utility System, then the Domestic Water Hours KPI Calculation shall only include the Equivalent Outage Hours for one University Building, which will be the highest Equivalent Outage Hours for one University Building for that Unplanned Outage.

- (lh) *KPI Calculation for Domestic Water – Unplanned Outage (Events): KPI Calculation Appendix 12*

The Key Performance Indicator for the number of events of Unplanned Outages for domestic water (including potable and fire protection) is determined on an

annual basis in each Fiscal Year to equal the number of unique Unplanned Outages for the Domestic Water Portion of the Utility System or any portion thereof (the “Domestic Water Events KPI Calculation”).

- (mi) *KPI Calculation for Sanitary Sewer – Unplanned Outage (Hours): KPI Calculation Appendix 13*

The Key Performance Indicator for the hours of Unplanned Outages for sanitary sewer is determined on an annual basis in each Fiscal Year by ~~dividing the number of hours that constitute an Unplanned Outage in that Fiscal Year~~ aggregating the Equivalent Outage Hours for the Sanitary Sewer Portion of the Utility System ~~by the total possible connection hours of the Sanitary Sewer Portion of the Utility System during that Fiscal Year, expressed as a percentage rounded to the nearest thousandth decimal point, and subtracting that result from 100%~~ (the “Sanitary Sewer Hours KPI Calculation”), provided that if one Unplanned Outage event affects multiple University Buildings for the Sanitary Sewer Portion of the Utility System, then the Sanitary Sewer Hours KPI Calculation shall only include the Equivalent Outage Hours for one University Building, which will be the highest Equivalent Outage Hours for one University Building for that Unplanned Outage.

- (nj) *KPI Calculation for Sanitary Sewer – Unplanned Outage (Events): KPI Calculation Appendix 14*

The Key Performance Indicator for the number of events of Unplanned Outages for sanitary sewer is determined on an annual basis in each Fiscal Year to equal the number of unique Unplanned Outages for the Sanitary Sewer Portion of the Utility System or any portion (the “Sanitary Sewer Events KPI Calculation”).

- (ok) *KPI Calculation for Storm Water – Unplanned Outage (Hours): KPI Calculation Appendix 15*

The Key Performance Indicator for the hours of Unplanned Outages for storm water is determined on an annual basis in each Fiscal Year by ~~dividing the number of hours that constitute an Unplanned Outage in that Fiscal Year~~ aggregating the Equivalent Outage Hours for the Storm Water Portion of the Utility System ~~by the total possible connection hours of the Storm Water Portion of the Utility System during that Fiscal Year, expressed as a percentage rounded to the nearest thousandth decimal point, and subtracting that result from 100%~~ (the “Storm Water Hours KPI Calculation”), provided that if one Unplanned Outage event affects multiple University Buildings for the Storm Water Portion of the Utility System, then the Storm Water Hours KPI Calculation shall only include the Equivalent Outage Hours for one University Building, which will be the highest Equivalent Outage Hours for one University Building for that Unplanned Outage.

- (p) *KPI Calculation for Storm Water – Unplanned Outage (Events): KPI Calculation Appendix 16*

The Key Performance Indicator for the number of events of Unplanned Outages for storm water is determined on an annual basis in each Fiscal Year to equal the number of unique Unplanned Outages for the Storm Water Portion of the Utility System or any portion thereof (the “Storm Water Events KPI Calculation”).

- (em) *KPI Calculation for Reclaimed Water – Unplanned Outage (Hours): KPI Calculation Appendix 17*

The Key Performance Indicator for the hours of Unplanned Outages for reclaimed, non-potable water is determined on an annual basis in each Fiscal Year by ~~dividing the number of hours that constitute an Unplanned Outage in that Fiscal Year~~ aggregating the Equivalent Outage Hours for the Reclaimed Water Portion of the Utility System ~~by the total possible connection hours of the Reclaimed Water Portion of the Utility System during that Fiscal Year, expressed as a percentage rounded to the nearest thousandth decimal point, and subtracting that result from 100%~~ (the “Reclaimed Water Hours KPI Calculation”), provided that if one Unplanned Outage event affects multiple University Buildings for the Reclaimed Water Portion of the Utility System, then the Reclaimed Water Hours KPI Calculation shall only include the Equivalent Outage Hours for one University Building, which will be the highest Equivalent Outage Hours for one University Building for that Unplanned Outage.

- (fn) *KPI Calculation for Reclaimed Water – Unplanned Outage (Events): KPI Calculation Appendix 18*

The Key Performance Indicator for the number of events of Unplanned Outages for reclaimed, non-potable water is determined on an annual basis in each Fiscal Year to equal the number of unique Unplanned Outages for the Reclaimed Water Portion of the Utility System or any portion thereof (the “Reclaimed Water Events KPI Calculation”).

- (so) *KPI Calculation for Compressed Air – Unplanned Outage (Hours): KPI Calculation Appendix 19*

The Key Performance Indicator for the hours of Unplanned Outages for compressed air is determined on an annual basis in each Fiscal Year by ~~dividing the number of hours that constitute an Unplanned Outage in that Fiscal Year~~ aggregating the Equivalent Outage Hours for the Compressed Air Portion of the Utility System ~~by the total possible connection hours of the Compressed Air Portion of the Utility System during that Fiscal Year, expressed as a percentage rounded to the nearest thousandth decimal point, and subtracting that result from 100%~~ (the “Compressed Air Hours KPI Calculation”), provided that if one Unplanned Outage event affects multiple University Buildings for the Compressed Air Portion of the Utility System, then the Compressed Air Hours

KPI Calculation shall only include the Equivalent Outage Hours for one University Building, which will be the highest Equivalent Outage Hours for one University Building for that Unplanned Outage.

- (tp) *KPI Calculation for Compressed Air – Unplanned Outage (Events): KPI Calculation Appendix 20*

The Key Performance Indicator for the number of events of Unplanned Outages for compressed air is determined on an annual basis in each Fiscal Year to equal the number of unique Unplanned Outages for the Compressed Air Portion of the Utility System or any portion (the “Compressed Air Events KPI Calculation”).

4. *Determination of KPI Compensation for each Availability KPI*

- (a) The KPI Compensation for each Availability KPI for a Fiscal Year is determined as follows:
- (i) If the applicable KPI Calculation meets the Target for that Availability KPI in that Fiscal Year, then the KPI Compensation for that Key Performance Indicator for that Fiscal Year is \$0;
 - (ii) If (A) such Fiscal Year is a KPI Event Year for that Availability KPI and (B) the immediately preceding Fiscal Year was not a KPI Event Year for that Availability KPI, then the KPI Compensation shall be the amount shown on the applicable KPI Calculation Appendix for that KPI Calculation under the column labeled “0 Consecutive Event Years” and in the row where the column labeled “Annual Score” includes the KPI Calculation in the applicable KPI Calculation Appendix; and
 - (iii) If such Fiscal Year and the immediately preceding Fiscal Year are both KPI Event Years for that Availability KPI, then the KPI Compensation shall be determined by adding the applicable KPI Calculation for the Fiscal Years during the KPI Measurement Window and dividing that sum by the number of Fiscal Years in the KPI Measurement Window and rounding to the decimal point set forth in the applicable KPI Calculation, or if none is provided, to the nearest whole number, (the “KPI Calculation Average”), in which case the KPI Compensation shall be the amount shown on the applicable KPI Calculation Appendix for that KPI Calculation under the column where the number equals the number of Fiscal Years in the KPI Measurement Window and the row where the column labeled “Annual Score” includes the KPI Calculation Average in the applicable KPI Calculation Appendix, provided that if the KPI Compensation for such Fiscal Year would be higher if calculated pursuant to sub-section (ii) hereof, then the KPI Compensation shall be calculated in accordance with sub-section (ii) as if the immediately preceding Fiscal Year was not a KPI Event Year.

- (b) The Concessionaire shall have the right, within sixty (60) Days following an Unplanned Outage for a Portion of the Utility System, to deliver notice to the University that it believes, in its reasonable discretion, that a single root cause caused an Unplanned Outage for multiple Portions of the Utility System, which notice shall include reasonable evidence supporting such conclusion. If the University, in its reasonable discretion, agrees that a single root cause caused an Unplanned Outage for multiple Portions of the Utility System, then it shall waive the Unplanned Outages for all Portions of the Utility System other than the Portion of the Utility System that the University, in its discretion, determines is the primary Portion of the Utility System affected by the root cause, solely for purposes of determining whether a KPI Event occurred in a particular Fiscal Year. For the avoidance of doubt, the Unplanned Outage for the primary Portion of the Utility System affected by the root cause shall be used to determine both the number of events of Unplanned Outages and the number of hours of Unplanned Outages for that Portion of the Utility System. For the avoidance of doubt, if more than one root cause for a Portion of the Utility System occurs concurrently and each root cause causes a separate Unplanned Outage, each root cause shall be treated as a separate Unplanned Outage event.

5. *KPI Calculation for each Operational KPI*

- (a) *KPI Calculation for Safety – Recordable Injury Rate: KPI Calculation Appendix 21*

The Key Performance Indicator for the total OSHA recordable frequency is the number of fatalities, lost time injuries, substitute work, and other injuries (except a hearing threshold shift) requiring treatment by a medical professional and required to be recorded by OSHA in the performance of the Utility Services in the performance of the Utility Services (the “Safety KPI”).

- (b) *KPI Calculation for Environmental Compliance – Annual Rate of Notices of Violation: KPI Calculation Appendix 22*

The Key Performance Indicator for environmental compliance will be the sum, in any given Fiscal Year, of the Notice of Violation notices received from the Idaho Department of Environmental Quality, the U.S. Environmental Protection Agency or a successor agency to either of the foregoing, or other Governmental Authority relating to compliance with Environmental Laws directly attributable to the Utility System, including its operation and maintenance, to the extent each such notice requires the payment of a fine or fee of \$1,000 or more (the “Environmental Compliance KPI”).

- (c) *KPI Calculation for Issuance of Public Notice Related to Water Quality: KPI Calculation Appendix 23*

The Key Performance Indicator for the issuance of public notices related to the quality of Domestic Water will be the sum of public notices sent by the Idaho

Department of Environmental Quality or any other Governmental Agency to the consumers of the Domestic Water Portion of the Utility System enforcing the Clean Water Act (33 U.S.C. §1321 et seq.) or any successor statute related to produced or distributed water quality (the “Public Notice of Water Quality KPI”).

6. *Determination of KPI Compensation for each Operational KPI*

- (a) The KPI Compensation for each Operational KPI for a Fiscal Year is determined as follows:
- (i) If the applicable KPI Calculation meets the Target for that Operational KPI in that Fiscal Year, then the KPI Compensation for that Key Performance Indicator for that Fiscal Year is \$0;
 - (ii) If (A) such Fiscal Year is a KPI Event Year for that Operational KPI and (B) the immediately preceding Fiscal Year was not a KPI Event Year for that Operational KPI, then the KPI Compensation shall be the amount shown on the applicable KPI Calculation Appendix for that KPI Calculation under the column labeled “0 Consecutive Event Years” and in the row where the column labeled “Annual Score” includes the KPI Calculation in the applicable KPI Calculation Appendix; and
 - (iii) If such Fiscal Year and the immediately preceding Fiscal Year are both KPI Event Years for that Operational KPI, then the KPI Compensation shall be determined by determining the KPI Calculation Average, in which case the KPI Compensation shall be the amount shown on the applicable KPI Calculation Appendix for that KPI Calculation under the column where the number equals the number of Fiscal Years in the KPI Measurement Window and the row where the column labeled “Annual Score” includes the KPI Calculation Average in the applicable KPI Calculation Appendix, provided that if the KPI Compensation for such Fiscal Year would be higher if calculated pursuant to sub-section (ii) hereof, then the KPI Compensation shall be calculated in accordance with sub-section (ii) as if the immediately preceding Fiscal Year was not a KPI Event Year.

7. *Delivery of KPI Calculations and Right to Audit any Key Performance Indicator Calculation*

- (a) Within thirty (30) Days after the expiration of the current Fiscal Year, the Concessionaire shall provide the University with written notice of its determination of all KPI Calculations and the KPI Compensation for the current Fiscal Year.
- (b) The records that the Concessionaire maintains with respect to the calculation of the actual KPI Calculations shall be retained by the Concessionaire for a period of 4 Fiscal Years following the Fiscal Year to which such KPI Calculations relate in an electronic or other form reasonably acceptable to the University. The

University shall have the right, through its Representatives, to examine, copy and audit such records at reasonable times, upon not less than five (5) Business Days' prior notice, at such place within the City of Moscow as the Concessionaire shall reasonably designate from time to time for the keeping of such records. All costs of any such audit shall be borne by the University; provided, however, that if such audit establishes that any KPI Compensation for any particular KPI Calculation for the applicable Fiscal Year was lower than the final determination thereof, as set forth in the statement delivered by the Concessionaire to the University, by at least 1.0%, then the Concessionaire shall pay the cost of such audit. If, as a result of such audit, it is determined that the Concessionaire under calculated the KPI Compensation for any particular Fiscal Year, such difference shall be included as KPI Compensation in the KPI Evaluation Period during which such determination was made.

BUSINESS AFFAIRS AND HUMAN RESOURCES
APRIL 17-18, 2024

KPI Calculation for Electricity Hours KPI Calculation

Annual Score		KPI Compensation to the University							
		0	2	3	4	5	6	7	8
% Availability Equivalent Outage Hours		Consecutive Event Years	Consecutive Event Years	Consecutive Event Years	Consecutive Event Years	Consecutive Event Years	Consecutive Event Years	Consecutive Event Years	Consecutive Event Years
Low	High								
Target-100.000% - 99.977% 0.000	<u>216.000</u>	\$ -	\$ -	\$ -	\$ -	\$ -	\$ -	\$ -	\$ -
99.976% 99.954% 2.16.001	<u>264.000</u>	\$ -	\$ -	\$ 50,000	\$ 100,000	\$ 200,000	\$ 400,000	\$ 800,000 <u>700,000</u>	\$ 1,000,000
99.953% 99.931% 2.64.001	<u>312.000</u>	\$ -	\$ 50,000	\$ 100,000	\$ 200,000	\$ 400,000	\$ 800,000 <u>700,000</u>	\$ 1,000,000	\$ 1,000,000
99.930% 99.908% 3.12.001	<u>360.000</u>	\$ 50,000	\$ 100,000	\$ 200,000	\$ 400,000	\$ 800,000 <u>700,000</u>	\$ 1,000,000	\$ 1,000,000	
99.907% 99.885% 3.60.001	<u>408.000</u>	\$ 100,000	\$ 200,000	\$ 400,000	\$ 800,000 <u>700,000</u>	\$ 1,000,000	\$ 1,000,000		
99.884% 99.862% 4.08.001	<u>456.000</u>	\$ 200,000	\$ 400,000	\$ 800,000 <u>700,000</u>	\$ 1,000,000	\$ 1,000,000			
99.861% 99.840% 4.56.001	<u>504.000</u>	\$ 400,000	\$ 800,000 <u>700,000</u>	\$ 1,000,000	\$ 1,000,000				
99.839% 99.817% 5.04.001	<u>552.000</u>	\$ 800,000 <u>700,000</u>	\$ 1,000,000	\$ 1,000,000					
← 99.817% 5.52.001	<u>N/A</u>	\$ 1,000,000	\$ 1,000,000						

**BUSINESS AFFAIRS AND HUMAN RESOURCES
APRIL 17-18, 2024**

ATTACHMENT 9

Schedule 15: KPI Calculation Appendix 2

KPI Calculation for Electricity Events KPI Calculation

Annual Score	KPI Compensation to the University							
	0	2	3	4	5	6	7	8
Number of Events	Consecutive Event Years	Consecutive Event Years	Consecutive Event Years	Consecutive Event Years	Consecutive Event Years	Consecutive Event Years	Consecutive Event Years	Consecutive Event Years
Target ≤ 2	\$ -	\$ -	\$ -	\$ -	\$ -	\$ -	\$ -	\$ -
3	\$ -	\$ -	\$ 25,000	\$ 50,000	\$ 100,000	\$ 200,000	\$ 400,000	\$ 500,000
4	\$ 50,000	\$ 100,000	\$ 200,000	\$ 400,000	\$ 500,000	\$ 500,000		
5	\$ 200,000	\$ 400,000	\$ 500,000	\$ 500,000				
6 or greater	\$ 500,000	\$ 500,000						

[KPI Calculation Appendix 3](#)

[Intentionally Omitted](#)

[KPI Calculation Appendix 4](#)

[Intentionally Omitted](#)

**BUSINESS AFFAIRS AND HUMAN RESOURCES
APRIL 17-18, 2024**

ATTACHMENT 9

Schedule 15: KPI Calculation Appendix 35

KPI Calculation for General Steam ~~Plant~~ Hours KPI Calculation

Annual Score		KPI Compensation to the University							
		0	2	3	4	5	6	7	8
% Availability Equivalent Outage Hours		Consecutive Event Years	Consecutive Event Years	Consecutive Event Years	Consecutive Event Years	Consecutive Event Years	Consecutive Event Years	Consecutive Event Years	Consecutive Event Years
Low	High								
Target-100.00% 99.15% 0.00	<u>72.000</u>	\$ -	\$ -	\$ -	\$ -	\$ -	\$ -	\$ -	\$ -
99.14% 98.29% 0.01	<u>120.000</u>	\$ -	\$ -	\$ 50,000 <u>35,000</u>	\$ 100,000 <u>70,000</u>	\$ 200,000 <u>140,000</u>	\$ 400,000 <u>280,000</u>	\$ 800,000 <u>490,000</u>	\$ 1,000,000 <u>700,000</u>
98.28% 97.44% 0.001	<u>168.000</u>	\$ -	\$ 50,000 <u>35,000</u>	\$ 100,000 <u>70,000</u>	\$ 200,000 <u>140,000</u>	\$ 400,000 <u>280,000</u>	\$ 800,000 <u>490,000</u>	\$ 1,000,000 <u>700,000</u>	\$ 1,000,000 <u>700,000</u>
97.43% 96.59% 0.001	<u>216.000</u>	\$ 50,000 <u>35,000</u>	\$ 100,000 <u>70,000</u>	\$ 200,000 <u>140,000</u>	\$ 400,000 <u>280,000</u>	\$ 800,000 <u>490,000</u>	\$ 1,000,000 <u>700,000</u>	\$ 1,000,000 <u>700,000</u>	
96.58% 95.74% 0.001	<u>264.000</u>	\$ 100,000 <u>70,000</u>	\$ 200,000 <u>140,000</u>	\$ 400,000 <u>280,000</u>	\$ 800,000 <u>490,000</u>	\$ 1,000,000 <u>700,000</u>	\$ 1,000,000 <u>700,000</u>		
95.73% 94.88% 0.001	<u>312.000</u>	\$ 200,000 <u>140,000</u>	\$ 400,000 <u>280,000</u>	\$ 800,000 <u>490,000</u>	\$ 1,000,000 <u>700,000</u>	\$ 1,000,000 <u>700,000</u>			
94.87% 94.03% 0.001	<u>360.000</u>	\$ 400,000 <u>280,000</u>	\$ 800,000 <u>490,000</u>	\$ 1,000,000 <u>700,000</u>	\$ 1,000,000 <u>700,000</u>				
94.02% 93.18% 0.001	<u>408.000</u>	\$ 800,000 <u>490,000</u>	\$ 1,000,000 <u>700,000</u>	\$ 1,000,000 <u>700,000</u>					
← 93.18% 0.001	<u>N/A</u>	\$ 1,000,000 <u>700,000</u>	\$ 1,000,000 <u>700,000</u>						

[NAI-1531701023v9](#)

**BUSINESS AFFAIRS AND HUMAN RESOURCES
APRIL 17-18, 2024**

ATTACHMENT 9

Schedule 15: KPI Calculation Appendix [46](#)

KPI Calculation for General Steam ~~Plant~~ Events KPI Calculation

Annual Score	KPI Compensation to the University							
	0	2	3	4	5	6	7	8
Number of Events	Consecutive Event Years	Consecutive Event Years	Consecutive Event Years	Consecutive Event Years	Consecutive Event Years	Consecutive Event Years	Consecutive Event Years	Consecutive Event Years
Target ≤ 3	\$ -	\$ -	\$ -	\$ -	\$ -	\$ -	\$ -	\$ -
4-3-4	\$ -	\$ -	\$ 50,000 25,000	\$ 100,000 50,000	\$ 200,000 100,000	\$ 400,000 200,000	\$ 800,000 400,000	\$ 1,000,000 500,000
5-5-6	\$ 100,000 50,000	\$ 200,000 100,000	\$ 400,000 200,000	\$ 800,000 400,000	\$ 1,000,000 500,000	\$ 1,000,000 500,000		
6-7-8	\$ 400,000 200,000	\$ 800,000 400,000	\$ 1,000,000 500,000	\$ 1,000,000 500,000				
7-9 or greater	\$ 1,000,000 500,000	\$ 1,000,000 500,000						

[KPI Calculation Appendix 7](#)

[Intentionally Omitted](#)

[KPI Calculation Appendix 8](#)

[Intentionally Omitted](#)

**BUSINESS AFFAIRS AND HUMAN RESOURCES
APRIL 17-18, 2024**

KPI Calculation for General ~~Steam~~Chilled Water Hours KPI Calculation

Annual Score		KPI Compensation to the University							
		0	2	3	4	5	6	7	8
%AvailabilityEquivalent Outage Hours		Consecutive Event Years	Consecutive Event Years	Consecutive Event Years	Consecutive Event Years	Consecutive Event Years	Consecutive Event Years	Consecutive Event Years	Consecutive Event Years
Low	High								
100.00% 0.00	<u>144.000</u>	\$ -	\$ -	\$ -	\$ -	\$ -	\$ -	\$ -	\$ -
98.89% 0.01	<u>192.000</u>	\$ -	\$ -	\$ 50,000 <u>35,000</u>	\$ 100,000 <u>70,000</u>	\$ 200,000 <u>140,000</u>	\$ 400,000 <u>280,000</u>	\$ 800,000 <u>490,000</u>	\$ 1,000,000 <u>700,000</u>
97.76% 0.01	<u>240.000</u>	\$ -	\$ 50,000 <u>35,000</u>	\$ 100,000 <u>70,000</u>	\$ 200,000 <u>140,000</u>	\$ 400,000 <u>280,000</u>	\$ 800,000 <u>490,000</u>	\$ 1,000,000 <u>700,000</u>	\$ 1,000,000 <u>700,000</u>
96.66% 0.01	<u>288.000</u>	\$ 50,000 <u>35,000</u>	\$ 100,000 <u>70,000</u>	\$ 200,000 <u>140,000</u>	\$ 400,000 <u>280,000</u>	\$ 800,000 <u>490,000</u>	\$ 1,000,000 <u>700,000</u>	\$ 1,000,000 <u>700,000</u>	
95.54% 0.01	<u>336.000</u>	\$ 100,000 <u>70,000</u>	\$ 200,000 <u>140,000</u>	\$ 400,000 <u>280,000</u>	\$ 800,000 <u>490,000</u>	\$ 1,000,000 <u>700,000</u>	\$ 1,000,000 <u>700,000</u>		
94.42% 0.01	<u>384.000</u>	\$ 200,000 <u>140,000</u>	\$ 400,000 <u>280,000</u>	\$ 800,000 <u>490,000</u>	\$ 1,000,000 <u>700,000</u>	\$ 1,000,000 <u>700,000</u>			
93.31% 0.01	<u>432.000</u>	\$ 400,000 <u>280,000</u>	\$ 800,000 <u>490,000</u>	\$ 1,000,000 <u>700,000</u>	\$ 1,000,000 <u>700,000</u>				
92.19% 0.01	<u>480.000</u>	\$ 800,000 <u>490,000</u>	\$ 1,000,000 <u>700,000</u>	\$ 1,000,000 <u>700,000</u>					
91.09% 0.01	<u>N/A</u>	\$ 1,000,000 <u>700,000</u>	\$ 1,000,000 <u>700,000</u>						

**BUSINESS AFFAIRS AND HUMAN RESOURCES
APRIL 17-18, 2024**

ATTACHMENT 9

Schedule 15:

KPI Calculation Appendix [610](#)

KPI Calculation for General ~~Steam~~Chilled Water Events KPI Calculation

Annual Score	KPI Compensation to the University							
	0	2	3	4	5	6	7	8
Number of Events	Consecutive Event Years	Consecutive Event Years	Consecutive Event Years	Consecutive Event Years	Consecutive Event Years	Consecutive Event Years	Consecutive Event Years	Consecutive Event Years
Target ≤ 2	\$ -	\$ -	\$ -	\$ -	\$ -	\$ -	\$ -	\$ -
3-4	\$ -	\$ -	\$ 25,000	\$ 50,000	\$ 100,000	\$ 200,000	\$ 400,000	\$ 800,000
5-6	\$ 50,000	\$ 100,000	\$ 200,000	\$ 400,000	\$ 800,000	\$ 1,000,000		
7-8	\$ 200,000	\$ 400,000	\$ 800,000	\$ 1,000,000				
9 or greater	\$ 500,000	\$ 1,000,000						

**BUSINESS AFFAIRS AND HUMAN RESOURCES
APRIL 17-18, 2024**

ATTACHMENT 9

Schedule 15: KPI Calculation Appendix [7.11](#)

KPI Calculation for ~~Chilled~~ Domestic Water ~~Tank~~ Hours KPI Calculation

Annual Score		KPI Compensation to the University							
		0	2	3	4	5	6	7	8
% Availability Equivalent Outage Hours		Consecutive Event Years	Consecutive Event Years	Consecutive Event Years	Consecutive Event Years	Consecutive Event Years	Consecutive Event Years	Consecutive Event Years	Consecutive Event Years
Low	High								
100.00% 99.95% 0	<u>144.000</u>	\$ -	\$ -	\$ -	\$ -	\$ -	\$ -	\$ -	\$ -
99.94% 99.90% 144.001	<u>192.000</u>	\$ -	\$ -	\$ 50,000 <u>35,000</u>	\$ 100,000 <u>70,000</u>	\$ 200,000 <u>140,000</u>	\$ 400,000 <u>280,000</u>	\$ 800,000 <u>490,000</u>	\$ 1,000,000 <u>700,000</u>
99.89% 99.85% 192.001	<u>240.000</u>	\$ -	\$ 50,000 <u>35,000</u>	\$ 100,000 <u>70,000</u>	\$ 200,000 <u>140,000</u>	\$ 400,000 <u>280,000</u>	\$ 800,000 <u>490,000</u>	\$ 1,000,000 <u>700,000</u>	\$ 1,000,000 <u>700,000</u>
99.84% 99.80% 240.001	<u>288.000</u>	\$ 50,000 <u>35,000</u>	\$ 100,000 <u>70,000</u>	\$ 200,000 <u>140,000</u>	\$ 400,000 <u>280,000</u>	\$ 800,000 <u>490,000</u>	\$ 1,000,000 <u>700,000</u>	\$ 1,000,000 <u>700,000</u>	
99.79% 99.75% 288.001	<u>336.000</u>	\$ 100,000 <u>70,000</u>	\$ 200,000 <u>140,000</u>	\$ 400,000 <u>280,000</u>	\$ 800,000 <u>490,000</u>	\$ 1,000,000 <u>700,000</u>	\$ 1,000,000 <u>700,000</u>		
99.74% 99.70% 336.001	<u>384.000</u>	\$ 200,000 <u>140,000</u>	\$ 400,000 <u>280,000</u>	\$ 800,000 <u>490,000</u>	\$ 1,000,000 <u>700,000</u>	\$ 1,000,000 <u>700,000</u>			
99.69% 99.64% 384.001	<u>432.000</u>	\$ 400,000 <u>280,000</u>	\$ 800,000 <u>490,000</u>	\$ 1,000,000 <u>700,000</u>	\$ 1,000,000 <u>700,000</u>				
99.63% 99.59% 432.001	<u>480.000</u>	\$ 800,000 <u>490,000</u>	\$ 1,000,000 <u>700,000</u>	\$ 1,000,000 <u>700,000</u>					
← 99.59% 480.001	<u>N/A</u>	\$ 1,000,000 <u>700,000</u>	\$ 1,000,000 <u>700,000</u>						

**BUSINESS AFFAIRS AND HUMAN RESOURCES
APRIL 17-18, 2024**

ATTACHMENT 9

Schedule 15: KPI Calculation Appendix [812](#)

KPI Calculation for ~~Chilled Domestic Water Tank~~ Events KPI Calculation

Annual Score	KPI Compensation to the University							
	0	2	3	4	5	6	7	8
Number of Events	Consecutive Event Years	Consecutive Event Years	Consecutive Event Years	Consecutive Event Years	Consecutive Event Years	Consecutive Event Years	Consecutive Event Years	Consecutive Event Years
Target ≤ 4 7	\$ -	\$ -	\$ -	\$ -	\$ -	\$ -	\$ -	\$ -
2-3 8-9	\$ -	\$ -	\$ 25,000	\$ 50,000	\$ 100,000	\$ 200,000	\$ 400,000	\$ 500,000
4-5 10-11	\$ 50,000	\$ 100,000	\$ 200,000	\$ 400,000	\$ 500,000	\$ 500,000		
6-7 12-13	\$ 200,000	\$ 400,000	\$ 500,000	\$ 500,000				
8 14 or greater	\$ 500,000	\$ 500,000						

**BUSINESS AFFAIRS AND HUMAN RESOURCES
APRIL 17-18, 2024**

ATTACHMENT 9

Schedule 15: KPI Calculation Appendix 9.13

KPI Calculation for ~~General Chilled Water~~ Sanitary Sewer Hours KPI Calculation

Annual Score		KPI Compensation to the University							
		0	2	3	4	5	6	7	8
% Availability Equivalent Outage Hours		Consecutive Event Years	Consecutive Event Years	Consecutive Event Years	Consecutive Event Years	Consecutive Event Years	Consecutive Event Years	Consecutive Event Years	Consecutive Event Years
Low	High								
Target- 100.000% 99.959% 0.000	216.000	\$ -	\$ -	\$ -	\$ -	\$ -	\$ -	\$ -	\$ -
-99.958% 99.919% 216.001	288.000	\$ -	\$ -	\$ 25,000 35,000	\$ 50,000 70,000	\$ 100,000 140,000	\$ 200,000 280,000	\$ 400,000 490,000	\$ 500,000 700,000
-99.918% 99.878% 288.001	360.000	\$ -	\$ 25,000 35,000	\$ 50,000 70,000	\$ 100,000 140,000	\$ 200,000 280,000	\$ 400,000 490,000	\$ 500,000 700,000	\$ 500,000 700,000
-99.877% 99.838% 360.001	432.000	\$ 25,000 35,000	\$ 50,000 70,000	\$ 100,000 140,000	\$ 200,000 280,000	\$ 400,000 490,000	\$ 500,000 700,000	\$ 500,000 700,000	
-99.837% 99.797% 432.001	504.000	\$ 50,000 70,000	\$ 100,000 140,000	\$ 200,000 280,000	\$ 400,000 490,000	\$ 500,000 700,000	\$ 500,000 700,000		
-99.796% 99.757% 504.001	576.000	\$ 100,000 140,000	\$ 200,000 280,000	\$ 400,000 490,000	\$ 500,000 700,000	\$ 500,000 700,000			
-99.756% 99.716% 576.001	648.000	\$ 200,000 280,000	\$ 400,000 490,000	\$ 500,000 700,000	\$ 500,000 700,000				
-99.715% 99.676% 648.001	720.000	\$ 400,000 490,000	\$ 500,000 700,000	\$ 500,000 700,000					
< 99.676% 720.001		\$ 500,000 700,000	\$ 500,000 700,000						

**BUSINESS AFFAIRS AND HUMAN RESOURCES
APRIL 17-18, 2024**

ATTACHMENT 9

Schedule 15: KPI Calculation Appendix [4014](#)

KPI Calculation for General Chilled Water <u>Sanitary Sewer</u> Events KPI Calculation
--

KPI Compensation to the University								
Annual Score	0	2	3	4	5	6	7	8
Number of Events	Consecutive Event Years	Consecutive Event Years	Consecutive Event Years	Consecutive Event Years	Consecutive Event Years	Consecutive Event Years	Consecutive Event Years	Consecutive Event Years
Target ≤ 1	\$ -	\$ -	\$ -	\$ -	\$ -	\$ -	\$ -	\$ -
2-3	\$ -	\$ -	\$ 50,000	\$ 100,000	\$ 200,000	\$ 400,000	\$ 800,000	\$ 1,000,000
4-5	\$ 100,000	\$ 200,000	\$ 400,000	\$ 800,000	\$ 1,000,000	\$ 1,000,000		
6-7	\$ 400,000	\$ 800,000	\$ 1,000,000	\$ 1,000,000				
8 or greater	\$ 1,000,000	\$ 1,000,000						

**BUSINESS AFFAIRS AND HUMAN RESOURCES
APRIL 17-18, 2024**

ATTACHMENT 9

Schedule 15: KPI Calculation Appendix 11

KPI Calculation for Domestic Storm Water Hours KPI Calculation

Annual Score		KPI Compensation to the University							
		0	2	3	4	5	6	7	8
% Availability Equivalent Outage Hours		Consecutive Event Years	Consecutive Event Years	Consecutive Event Years	Consecutive Event Years	Consecutive Event Years	Consecutive Event Years	Consecutive Event Years	Consecutive Event Years
Low	High								
Target 100.00% 99.72% 0	<u>216.000</u>	\$ -	\$ -	\$ -	\$ -	\$ -	\$ -	\$ -	\$ -
99.71% 99.45% 001	<u>288.000</u>	\$ -	\$ -	\$ 50,000 <u>20,000</u>	\$ 100,000 <u>40,000</u>	\$ 200,000 <u>80,000</u>	\$ 400,000 <u>160,000</u>	\$ 800,000 <u>280,000</u>	\$ 1,000,000 <u>400,000</u>
99.44% 99.17% 001	<u>360.000</u>	\$ -	\$ 50,000 <u>20,000</u>	\$ 100,000 <u>40,000</u>	\$ 200,000 <u>80,000</u>	\$ 400,000 <u>160,000</u>	\$ 800,000 <u>280,000</u>	\$ 1,000,000 <u>400,000</u>	\$ 1,000,000 <u>400,000</u>
99.16% - 98.89%		\$ 50,000	\$ 100,000	\$ 200,000	\$ 400,000	\$ 800,000	\$ 1,000,000	\$ 1,000,000	-
98.88% - 98.62%		\$ 100,000	\$ 200,000	\$ 400,000	\$ 800,000	\$ 1,000,000	\$ 1,000,000	-	-
98.61% - 98.34%		\$ 200,000	\$ 400,000	\$ 800,000	\$ 1,000,000	\$ 1,000,000	-	-	-
98.33% - 98.07%		\$ 400,000	\$ 800,000	\$ 1,000,000	\$ 1,000,000	-	-	-	-
98.06% - 97.79%		\$ 800,000	\$ 1,000,000	\$ 1,000,000	-	-	-	-	-
< 97.79%		\$ 1,000,000	\$ 1,000,000	-	-	-	-	-	-

**BUSINESS AFFAIRS AND HUMAN RESOURCES
APRIL 17-18, 2024**

ATTACHMENT 9

Schedule 15:

KPI Calculation Appendix 12

KPI Calculation for Domestic Water Events KPI Calculation

	KPI Compensation to the University							
Annual Score	0	2	3	4	5	6	7	8
Number of Events	Consecutive Event Years	Consecutive Event Years	Consecutive Event Years	Consecutive Event Years	Consecutive Event Years	Consecutive Event Years	Consecutive Event Years	Consecutive Event Years
Target ≤ 7	\$ _____	\$ _____	\$ _____	\$ _____	\$ _____	\$ _____	\$ _____	\$ _____
8-9	\$ _____	\$ _____	\$ 25,000	\$ 50,000	\$ 100,000	\$ 200,000	\$ 400,000	\$ 500,000
10-11	\$ 50,000	\$ 100,000	\$ 200,000	\$ 400,000	\$ 500,000	\$ 500,000	-	-
12-13	\$ 200,000	\$ 400,000	\$ 500,000	\$ 500,000	-	-	-	-
14 or greater	\$ 500,000	\$ 500,000	-	-	-	-	-	-

**BUSINESS AFFAIRS AND HUMAN RESOURCES
APRIL 17-18, 2024**

ATTACHMENT 9

Schedule 15: KPI Calculation Appendix 1315

KPI Calculation for Sanitary Sewer Hours KPI Calculation

Annual Score	0	KPI Compensation to the University							
		2	3	4	5	6	7	8	
% Availability	Consecutive Event Years	Consecutive Event Years	Consecutive Event Years	Consecutive Event Years	Consecutive Event Years	Consecutive Event Years	Consecutive Event Years	Consecutive Event Years	Consecutive Event Years
Target 100.000% - 99.808%	\$ —	\$ —	\$ —	\$ —	\$ —	\$ —	\$ —	\$ —	\$ —
99.807% - 99.615%	\$ —	\$ —	\$ —	\$ —	\$ 50,000	\$ 100,000	\$ 200,000	\$ 400,000	\$ 400,000
99.614% - 99.423%	\$ —	\$ —	\$ —	\$ 50,000	\$ 100,000	\$ 200,000	\$ 400,000	\$ 400,000	\$ 400,000
99.422% 99.231% 360.001	\$ 432,000 20,000	\$ 40,000	\$ 80,000	\$ 160,000	\$ 280,000	\$ 400,000	\$ 400,000		
99.230% 99.039% 432.001	\$ 504,000 40,000	\$ 80,000	\$ 160,000	\$ 280,000	\$ 400,000	\$ 400,000			
99.038% 98.846% 504.001	\$ 576,000 80,000	\$ 160,000	\$ 280,000	\$ 400,000	\$ 400,000				
98.845% 98.654% 576.001	\$ 648,000 160,000	\$ 280,000	\$ 400,000	\$ 400,000					
98.653% 98.462% 648.001	\$ 720,000 280,000	\$ 400,000	\$ 400,000						
← 98.462% 720.001	\$ 400,000	\$ 400,000							

**BUSINESS AFFAIRS AND HUMAN RESOURCES
APRIL 17-18, 2024**

ATTACHMENT 9

Schedule 15: KPI Calculation Appendix [4416](#)

KPI Calculation for Sanitary Sewer Storm Water Events KPI Calculation

KPI Compensation to the University								
Annual Score	0	2	3	4	5	6	7	8
Number of Events	Consecutive Event Years	Consecutive Event Years	Consecutive Event Years	Consecutive Event Years	Consecutive Event Years	Consecutive Event Years	Consecutive Event Years	Consecutive Event Years
Target ≤ 1	\$ -	\$ -	\$ -	\$ -	\$ -	\$ -	\$ -	\$ -
2-3	\$ -	\$ -	\$ 50,000	\$ 100,000	\$ 200,000	\$ 400,000	\$ 800,000	\$ 1,000,000
4-5	\$ 100,000	\$ 200,000	\$ 400,000	\$ 800,000	\$ 1,000,000	\$ 1,000,000		
6-7	\$ 400,000	\$ 800,000	\$ 1,000,000	\$ 1,000,000				
8 or greater	\$ 1,000,000	\$ 1,000,000						

**BUSINESS AFFAIRS AND HUMAN RESOURCES
APRIL 17-18, 2024**

ATTACHMENT 9

Schedule 15: KPI Calculation Appendix 4517

KPI Calculation for Storm Reclaimed Water Hours KPI Calculation

Annual Score		KPI Compensation to the University							
		0	2	3	4	5	6	7	8
% Availability Equivalent Outage Hours		Consecutive Event Years	Consecutive Event Years	Consecutive Event Years	Consecutive Event Years	Consecutive Event Years	Consecutive Event Years	Consecutive Event Years	Consecutive Event Years
Low	High								
Target- 100.000% 99.808% 0.000	72.000	\$ -	\$ -	\$ -	\$ -	\$ -	\$ -	\$ -	\$ -
-99.807% 99.615% 72.001	120.000	\$ -	\$ -	\$ 20,000	\$ 40,000	\$ 80,000	\$ 160,000	\$ 280,000	\$ 400,000
-99.614% 99.423% 120.001	168.000	\$ -	\$ 20,000	\$ 40,000	\$ 80,000	\$ 160,000	\$ 280,000	\$ 400,000	\$ 400,000
-99.422% 99.231% 168.001	216.000	\$ 20,000	\$ 40,000	\$ 80,000	\$ 160,000	\$ 280,000	\$ 400,000	\$ 400,000	
-99.230% 99.039% 216.001	264.000	\$ 40,000	\$ 80,000	\$ 160,000	\$ 280,000	\$ 400,000	\$ 400,000		
-99.038% 98.846% 264.001	312.000	\$ 80,000	\$ 160,000	\$ 280,000	\$ 400,000	\$ 400,000			
-98.845% 98.654% 312.001	360.000	\$ 160,000	\$ 280,000	\$ 400,000	\$ 400,000				
-98.653% 98.462% 360.001	408.000	\$ 280,000	\$ 400,000	\$ 400,000					
< 98.462% 408.001		\$ 400,000	\$ 400,000						

**BUSINESS AFFAIRS AND HUMAN RESOURCES
APRIL 17-18, 2024**

ATTACHMENT 9

Schedule 15: KPI Calculation Appendix [4618](#)

KPI Calculation for ~~Storm~~Reclaimed Water Events KPI Calculation

Annual Score	KPI Compensation to the University							
	0	2	3	4	5	6	7	8
Number of Events	Consecutive Event Years	Consecutive Event Years	Consecutive Event Years	Consecutive Event Years	Consecutive Event Years	Consecutive Event Years	Consecutive Event Years	Consecutive Event Years
Target ≤ 1	\$ -	\$ -	\$ -	\$ -	\$ -	\$ -	\$ -	\$ -
2-3	\$ -	\$ -	\$ 50,000	\$ 100,000	\$ 200,000	\$ 400,000	\$ 800,000	\$ 1,000,000
4-5	\$ 100,000	\$ 200,000	\$ 400,000	\$ 800,000	\$ 1,000,000	\$ 1,000,000		
6-7	\$ 400,000	\$ 800,000	\$ 1,000,000	\$ 1,000,000				
8 or greater	\$ 1,000,000	\$ 1,000,000						

**BUSINESS AFFAIRS AND HUMAN RESOURCES
APRIL 17-18, 2024**

ATTACHMENT 9

Schedule 15: KPI Calculation Appendix 17

KPI Calculation for Reclaimed Water Compressed Air Hours KPI Calculation

Annual Score		KPI Compensation to the University							
		0	2	3	4	5	6	7	8
% Availability Equivalent Outage Hours		Consecutive Event Years	Consecutive Event Years	Consecutive Event Years	Consecutive Event Years	Consecutive Event Years	Consecutive Event Years	Consecutive Event Years	Consecutive Event Years
Low	High								
Target- 100.000% 99.988% 0.000	<u>72.000</u>	\$ -	\$ -	\$ -	\$ -	\$ -	\$ -	\$ -	\$ -
99.987% 99.975% 0.001	<u>120.000</u>	\$ -	\$ -	\$ 50,000 <u>20,000</u>	\$ 100,000 <u>40,000</u>	\$ 200,000 <u>80,000</u>	\$ 400,000 <u>160,000</u>	\$ 800,000 <u>280,000</u>	\$ 1,000,000 <u>400,000</u>
99.974% - 99.963%		\$ -	\$ 50,000	\$ 100,000	\$ 200,000	\$ 400,000	\$ 800,000	\$ 1,000,000	\$ 1,000,000
99.962% - 99.950% 0.001	<u>168.000</u>	\$ 50,000 -	\$ 100,000 <u>20,000</u>	\$ 200,000 <u>40,000</u>	\$ 400,000 <u>80,000</u>	\$ 800,000 <u>160,000</u>	\$ 1,000,000 <u>280,000</u>	\$ 1,000,000 <u>400,000</u>	\$ 400,000
99.949% - 99.938%		\$ 100,000	\$ 200,000	\$ 400,000	\$ 800,000	\$ 1,000,000	\$ 1,000,000	-	-
99.937% - 99.925% 0.001	<u>216.000</u>	\$ 200,000 <u>20,000</u>	\$ 400,000 <u>40,000</u>	\$ 800,000 <u>80,000</u>	\$ 1,000,000 <u>160,000</u>	\$ 1,000,000 <u>280,000</u>	\$ 400,000	\$ 400,000	
99.924% - 99.913%		\$ 400,000	\$ 800,000	\$ 1,000,000	\$ 1,000,000	-	-	-	-
99.912% - 99.900%		\$ 800,000	\$ 1,000,000	\$ 1,000,000	-	-	-	-	-
< 99.900%		\$ 1,000,000	\$ 1,000,000	-	-	-	-	-	-

**BUSINESS AFFAIRS AND HUMAN RESOURCES
APRIL 17-18, 2024**

ATTACHMENT 9

Schedule 15:

KPI Calculation Appendix 18

KPI Calculation for Reclaimed Water Events KPI Calculation

Annual Score		KPI Compensation to the University							
		0	2	3	4	5	6	7	8
Number of Events		Consecutive Event Years	Consecutive Event Years	Consecutive Event Years	Consecutive Event Years	Consecutive Event Years	Consecutive Event Years	Consecutive Event Years	Consecutive Event Years
Target ≤ 1		\$ —	\$ —	\$ —	\$ —	\$ —	\$ —	\$ —	\$ —
-2 <u>3</u>	216,001 <u>264,000</u>	\$ — 40,000	\$ — 80,000	\$ 50,000 160,000	\$ 100,000 280,000	\$ 200,000 400,000	\$ 400,000	\$ 800,000	\$ 1,000,000
-4 <u>5</u>	264,001 <u>312,000</u>	\$ 100,000 80,000	\$ 200,000 160,000	\$ 400,000 280,000	\$ 800,000 400,000	\$ 1,000,000 400,000	\$ 1,000,000		
-6 <u>7</u>	312,001 <u>360,000</u>	\$ 400,000	\$ 800,000	\$ 1,000,000	\$ 1,000,000	-	-	-	-
-8 <u>or greater</u>	360,001 <u>408,000</u>	\$ 1,000,000	\$ 1,000,000	-	-	-	-	-	-

**BUSINESS AFFAIRS AND HUMAN RESOURCES
APRIL 17-18, 2024**

ATTACHMENT 9

Schedule 15: KPI Calculation Appendix 19

KPI Calculation for Compressed Air Hours KPI Calculation

Annual Score		KPI Compensation to the University							
		0	2	3	4	5	6	7	8
% Availability		Consecutive Event Years	Consecutive Event Years	Consecutive Event Years	Consecutive Event Years	Consecutive Event Years	Consecutive Event Years	Consecutive Event Years	Consecutive Event Years
Target 100.000% - 99.988%		\$ —	\$ —	\$ —	\$ —	\$ —	\$ —	\$ —	\$ —
99.987% - 99.975%		\$ —	\$ —	\$ 50,000	\$ 100,000	\$ 200,000	\$ 400,000	\$ 800,000	\$ 1,000,000
99.974% 99.963% 312 <u>.001</u>	360.000 360.000	\$ — <u>160,000</u>	\$ 50,000 <u>280,000</u>	\$ 100,000 <u>400,000</u>	\$ 200,000 <u>400,000</u>	400,000	800,000	1,000,000	1,000,000
99.962% 99.950% 360 <u>.001</u>	408.000 408.000	\$ 50,000 <u>280,000</u>	\$ 100,000 <u>400,000</u>	\$ 200,000 <u>400,000</u>	400,000	800,000	1,000,000	1,000,000	
99.949% - 99.938%		100,000	200,000	400,000	800,000	1,000,000	1,000,000	-	-
99.937% - 99.925%		200,000	400,000	800,000	1,000,000	1,000,000	-	-	-
99.924% - 99.913%		400,000	800,000	1,000,000	1,000,000	-	-	-	-
99.912% 99.900% 408 <u>.001</u>		\$ 800,000 <u>400,000</u>	\$ 1,000,000 <u>400,000</u>	1,000,000					
< 99.900%		1,000,000	1,000,000	-	-	-	-	-	-

**BUSINESS AFFAIRS AND HUMAN RESOURCES
APRIL 17-18, 2024**

ATTACHMENT 9

Schedule 15: KPI Calculation Appendix 20

KPI Calculation for Compressed Air Events KPI Calculation

Annual Score	KPI Compensation to the University							
	0	2	3	4	5	6	7	8
Number of Events	Consecutive Event Years	Consecutive Event Years	Consecutive Event Years	Consecutive Event Years	Consecutive Event Years	Consecutive Event Years	Consecutive Event Years	Consecutive Event Years
Target ≤ 1	\$ -	\$ -	\$ -	\$ -	\$ -	\$ -	\$ -	\$ -
2-3	\$ -	\$ -	\$ 50,000	\$ 100,000	\$ 200,000	\$ 400,000	\$ 800,000	\$ 1,000,000
4-5	\$ 100,000	\$ 200,000	\$ 400,000	\$ 800,000	\$ 1,000,000	\$ 1,000,000		
6-7	\$ 400,000	\$ 800,000	\$ 1,000,000	\$ 1,000,000				
8 or greater	\$ 1,000,000	\$ 1,000,000						

**BUSINESS AFFAIRS AND HUMAN RESOURCES
APRIL 17-18, 2024**

ATTACHMENT 9

Schedule 15: KPI Calculation Appendix 21

KPI Calculation for Safety

Annual Score	KPI Compensation to the University							
	0	2	3	4	5	6	7	8
Number of Events	Consecutive Event Years	Consecutive Event Years	Consecutive Event Years	Consecutive Event Years	Consecutive Event Years	Consecutive Event Years	Consecutive Event Years	Consecutive Event Years
Target ≤ 1	\$ -	\$ -	\$ -	\$ -	\$ -	\$ -	\$ -	\$ -
2-3	\$ -	\$ -	\$ 25,000	\$ 50,000	\$ 100,000	\$ 400,000	\$ 400,000	\$ 500,000
4-5	\$ 50,000	\$ 100,000	\$ 200,000	\$ 400,000	\$ 500,000	\$ 500,000		
6-7	\$ 200,000	\$ 400,000	\$ 500,000	\$ 500,000				
8 or greater	\$ 500,000	\$ 500,000						

**BUSINESS AFFAIRS AND HUMAN RESOURCES
APRIL 17-18, 2024**

ATTACHMENT 9

Schedule 15: KPI Calculation Appendix 22

KPI Calculation for Environmental Compliance

Annual Score	KPI Compensation to the University							
	0	2	3	4	5	6	7	8
Number of Events	Consecutive Event Years	Consecutive Event Years	Consecutive Event Years	Consecutive Event Years	Consecutive Event Years	Consecutive Event Years	Consecutive Event Years	Consecutive Event Years
Target ≤ 1	\$ -	\$ -	\$ -	\$ -	\$ -	\$ -	\$ -	\$ -
2-3	\$ -	\$ -	\$ 25,000	\$ 50,000	\$ 100,000	\$ 400,000	\$ 500,000	\$ 500,000
4-5	\$ 50,000	\$ 100,000	\$ 200,000	\$ 400,000	\$ 500,000	\$ 500,000		
6-7	\$ 200,000	\$ 400,000	\$ 500,000	\$ 500,000				
8 or greater	\$ 500,000	\$ 500,000						

**BUSINESS AFFAIRS AND HUMAN RESOURCES
APRIL 17-18, 2024**

KPI Calculation for Public Notice of Water Quality

Annual Score	KPI Compensation to the University							
	0	2	3	4	5	6	7	8
Number of Events	Consecutive Event Years	Consecutive Event Years	Consecutive Event Years	Consecutive Event Years	Consecutive Event Years	Consecutive Event Years	Consecutive Event Years	Consecutive Event Years
Target ≤ 1	\$ -	\$ -	\$ -	\$ -	\$ -	\$ -	\$ -	\$ -
2-3	\$ -	\$ -	\$ 25,000	\$ 50,000	\$ 100,000	\$ 400,000	\$ 500,000	\$ 500,000
4-5	\$ 50,000	\$ 100,000	\$ 200,000	\$ 400,000	\$ 500,000	\$ 500,000		
6-7	\$ 200,000	\$ 400,000	\$ 500,000	\$ 500,000				
8 or greater	\$ 500,000	\$ 500,000						

BUSINESS AFFAIRS AND HUMAN RESOURCES
APRIL 17-18, 2024

ATTACHMENT 9

Schedule 15: KPI Calculation Appendix [2324](#)

Criticality Factor

<u>Bldg #</u>	<u>Name</u>	<u>Criticality Factor</u>
1	ADMINISTRATION BUILDING	1
3	ART & ARCHITECTURE NORTH	1
4	ARCHIE PHINNEY HALL	1
5	FOOD RESEARCH CENTER	1
6	GRADUATE ART STUDIO	1
7	MARY E. FORNEY HALL	1
9	GIBB HALL	1
10	GERTRUDE L. HAYS HALL	1
11	UNIVERSITY ENERGY PLANT	1
12	STUDENT HEALTH CENTER	1
14	MENARD LAW BUILDING	1
15	MEMORIAL GYM	1
16	ART & ARCHITECTURE BUILDING	1
17	MORRILL HALL	1
18	RIDENBAUGH HALL	1
19	LIFE SCIENCES SOUTH	1
20	BRUCE M. PITMAN CENTER	1
21	CAROL RYRIE BRINK HALL (FOCE)	1
22	ART & ARCHITECTURE SOUTH	1
25	IDDINGS AG SCIENCE BUILDING	1
26	HAMPTON MUSIC BUILDING	1
28	JANSSEN ENGINEERING BLDG	1
30	NICCOLLS BUILDING	1
32	LIBRARY	1
33	HOLM CENTER	1
34	BLAKE HOUSE	1
35	J.W. MARTIN LAB	1
36	RADIO-TV CENTER	1
38	MINES BUILDING	1
39	MCCONNELL HALL	1
41	SHOUP HALL	1
42	TARGHEE HALL	1
44	CLASS ANNEX	0.5
47	RENFREW HALL	1
48	UNIVERSITY ADVANCEMENT ANNEX	1
49	ENGINEERING ANNEX	0.5
52	THEOPHILUS TOWER	1
53	UI SWIMMING CENTER	1
54	BUCHANAN ENGINEERING LAB	1
55	COLLEGE OF NATURAL RESOURCES	1
56	PHYSICAL EDUCATION BLDG	1
58	ANIMAL PAVILION & MEATS LAB	1

[NAI-15317010](#)

BUSINESS AFFAIRS AND HUMAN RESOURCES
APRIL 17-18, 2024

ATTACHMENT 9

Schedule 15: KPI Calculation Appendix [2324](#)

59	GOLF CART STORAGE SHED	0.25
60	HUMAN RESOURCES	1
61	ENVIRONMENTAL HEALTH & SAFETY	1
62	SOUTH HILL COMMUNITY CENTER	0.25
63	AQUACULTURE WET LAB	1
64	PUMPHOUSE 5	1
65	HARTUNG THEATRE	1
70	PUMPHOUSE 3	1
72	FARM RESIDENCE - BEEF	1
73	FARM OPERATIONS SHOP	0.5
74	BEEF BARN 1	0.25
75	BEEF BARN 2	0.25
76	BEEF SHELTER 212	0.25
77	BEEF SHLT 214A/DRY HEIFER SHED	0.25
78	FARM STORAGE BUILDING #1	0.25
79	USDA RESEARCH BARN	0.25
80	FARM STORAGE BUILDING #2	0.25
81	AQUACULTURE INSTITUTE	1
82	FEED & STORAGE POULTRY 1	0.25
83	LONGHOUSE	0.25
85	ARBORETUM BARN	0.25
89	PUMPHOUSE 4	1
91	JACOB MONSON MEMORIAL BARN	0.25
92	MILKING PARLOR	1
93	WWAMI MEDICAL EDUCATION BLDG	1
94	EARLY CHILDHOOD LRNG CENTER	1
97	IDAHO COMMONS	1
99	PREEC GREENHOUSES (4 UNITS)	0.5
100	GOLF COURSE CLUBHOUSE	1
104	NATIVE AMERICAN/MIGRANT ED CTR	1
106	VIRTUAL TECHNOLOGY & DESIGN	1
110	MCCLURE HALL	1
111	ENGINEERING/PHYSICS BLDG	1
113	MANIS ENTOMOLOGY RESEARCH LAB	1
114	ASUI KIBBIE ACTIVITY CTR / VAC	1
115	MIKE RYAN TRACK & FIELD OFFICE	0.25
116	WICKS FIELD STORAGE & RESTROOM	0.25
119	GOLF COURSE MAINTENANCE BLDG	0.25
120	SHEEP BARN #1	0.25
122	BEEF BARN #3	0.25
123	VET SCI RES BARN/CATTLE ISOLA	0.25
124	SHAVINGS SHED	0.25
125	HAZARDOUS MATERIALS STORAGE	1
126	OBSERVATORY	0.25
129	BEEF WORKING FACILITY	0.25

[NAI-15317010](#)

BUSINESS AFFAIRS AND HUMAN RESOURCES
APRIL 17-18, 2024

ATTACHMENT 9

Schedule 15: KPI Calculation Appendix ~~23~~24

130	METABOLISM/SURGERY BUILDING	0.25
132	PESTICIDE STORAGE	0.25
143	STUDENT RECREATION CENTER	1
144	IRRIGATION SYSTEM PUMPHOUSE	1
147	AGRICULTURAL EDUCATION	1
196	KIBBIE WEST TICKET BOOTH	0.25
275	BOOKSTORE/US POST OFFICE	1
330	FARM RESIDENCE - DAIRY	0.25
331	NORTH FARM SCALE HOUSE	0.25
332	MILLING ROOM	0.25
333	MIXING ROOM	0.25
334	FEED STORAGE	0.25
335	CALF BARN	0.5
336	LOAFING BARN	0.25
337	DRY COW SHELTER	0.25
338	HAY SHED	0.25
339	HEIFER BARN	0.25
340	COMMODITY BUILDING	0.25
341	MATERNITY/RESEARCH BARN	0.25
342	FEEDING BARN #1	0.25
343	FEEDING BARN #2	0.25
344	FEEDING BARN #3	0.25
345	UPRIGHT SILO	0.25
346	DAIRY PUMPHOUSE	1
350	SHEEP SHELTER 301	0.25
351	SHEEP SHELTER 302	0.25
352	SHEEP SHELTER 304	0.25
353	SHEEP SHELTER 305A	0.25
354	SHEEP SHELTER 306	0.25
355	SHEEP SHELTER 307	0.25
356	SHEEP SHELTER 308	0.25
357	LAMBING BARN	0.25
358	SHEEP BARN #2	0.25
359	FARM RESIDENCE - SHEEP	0.25
360	FARM STORAGE BUILDING #3	0.25
361	SHEEP WORKING FACILITY	0.25
363	MANIS ENTOMOLOGY LAB	1
364	MANIS HOST PLANT RESISTANCE LAB	0.25
366	MANIS LAB STORAGE SHED 1	0.25
367	MANIS LAB STORAGE SHED 2	0.25
368	MANIS LAB STORAGE SHED 3	0.25
369	MANIS LAB STORAGE SHED 4	0.25
370	MANIS LAB STORAGE SHED 5	0.25
375	BEEF SHELTER 215	0.25
376	BEEF SHELTER 214B	0.25

NAI-15317010

BUSINESS AFFAIRS AND HUMAN RESOURCES
APRIL 17-18, 2024

ATTACHMENT 9

Schedule 15: KPI Calculation Appendix ~~23~~24

377	BEEF SHELTER 216	0.25
378	BEEF SHELTER 213	0.25
379	TRUCK SHED	0.25
380	SEED ROOM	0.25
381	MACHINE SHED	0.25
384	ISOLATION BARN	0.25
385	ISOLATION HOUSE #1	0.25
386	ISOLATION HOUSE #2	0.25
387	ISOLATION HOUSE #3	0.25
388	ISOLATION HOUSE #4	0.25
389	MONSON WORKING FACILITY	0.25
390	USDA INCINERATOR	0.25
391	USDA SHAVINGS SHED	0.25
392	HORSE SHELTER #2	0.25
393	HORSE SHELTER #1	0.25
398	MANIS LAB STORAGE SHED 6	0.25
399	ANIMAL & VET SCI RESEARCH BARN	0.25
403	VEHICLE RESEARCH LAB	0.5
404	FACILITIES GARAGE	0.5
405	LES SMALL ENGINE SHOP	0.5
406	UNIVERSITY VEHICLE STORAGE	0.25
407	PUMPHOUSE 9	1
420	RECYCLING/SURPLUS	0.5
421	ART & ARCHITECTURE EAST	1
422	AGRICULTURAL BIOTECHNOLOGY	1
423	GAUSS-JOHNSON ENGINEERING LAB	1
424	J. A. ALBERTSON	1
426	SEED POTATO GERMPASM LABORATORY	1
441	ALPHA KAPPA LAMBDA	1
447	FARM HOUSE	1
456	SIGMA CHI	1
458	ALPHA GAMMA RHO	1
460	ALPHA GAMMA DELTA	1
500	SOUTH HILL TERRACE- 418 TAYLOR	1
501	SOUTH HILL TERRACE- 426 TAYLOR	1
502	SOUTH HILL TERRACE- 430 TAYLOR	1
503	SOUTH HILL TERRACE- 458 TAYLOR	1
504	SOUTH HILL TERRACE- 464 TAYLOR	1
506	SOUTH HILL TERRACE- 486 TAYLOR	1
507	SOUTH HILL TERRACE- 492 TAYLOR	1
508	SOUTH HILL APTS - 506 TAYLOR	1
509	SOUTH HILL APTS - 510 TAYLOR	1
510	SOUTH HILL APTS - 528 TAYLOR	1
511	SOUTH HILL APTS - 524 TAYLOR	1
512	SOUTH HILL APTS - 514 TAYLOR	1

NAI-15317010

BUSINESS AFFAIRS AND HUMAN RESOURCES
APRIL 17-18, 2024

ATTACHMENT 9

Schedule 15: KPI Calculation Appendix [2324](#)

513	SOUTH HILL APTS - 518 TAYLOR	1
514	SOUTH HILL APTS - 1020 DEAKIN	1
515	SOUTH HILL APTS - 1011 DEAKIN	1
516	SOUTH HILL APTS - 1012 DEAKIN	1
517	SOUTH HILL APTS - 1016 DEAKIN	1
530	SOUTH HILL VISTA - 301 SWEET	1
531	SOUTH HILL VISTA - 303 SWEET	1
532	SOUTH HILL VISTA - 307 SWEET	1
533	SOUTH HILL VISTA - 311 SWEET	1
534	SOUTH HILL VISTA - 315 SWEET	1
535	SOUTH HILL VISTA - 319 SWEET	1
536	SOUTH HILL VISTA - 380 TAYLOR	1
537	SOUTH HILL VISTA - 374 TAYLOR	1
538	SOUTH HILL VISTA - 354 TAYLOR	1
539	SOUTH HILL VISTA - 350 TAYLOR	1
540	SOUTH HILL VISTA - 342 TAYLOR	1
541	SOUTH HILL VISTA - 334 TAYLOR	1
542	LLC - GEM - BLDG 1	1
543	LLC - SYRINGA - BLDG 2	1
544	LLC - SAGE - BLDG 3	1
545	LLC - UPHAM - BLDG 4	1
546	LLC - CNR - BLDG 5	1
547	LLC - GAULT - BLDG 6	1
548	LLC - ENGINEERING - BLDG 7	1
549	LLC - SCHOLARS - BLDG 8	1
550	WALLACE RESIDENCE- COMMON	1
551	WALLACE RESIDENCE- STEVENSON	1
552	WALLACE RESIDENCE- BALLARD	1
553	WALLACE RESIDENCE- WILLEY	1
554	WALLACE RESIDENCE- GOODING	1
569	ELMWOOD APARTMENTS	1
678	TEACHING & LEARNING CENTER	1
680	POULTRY HILL WAREHOUSE	0.25
681	RADIATION STORAGE BUILDING	1
685	AVS RESEARCH HAY BARN	0.25
687	NIATT CCVT STORAGE BUILDING	0.5
688	CHEMICAL STORAGE	1
689	FACILITIES SERVICES	1
690	FACILITIES LATHHOUSE/GRNHOUSE	0.25
691	FACILITIES STORAGE	0.25
693	UNIV EVENTS/BOOKSTORE STORAGE	0.25
694	HOUSING STORAGE	0.25
695	CAMPUS STORAGE #1	0.25
749	SOUTH CAMPUS CHILLER PLANT	1
758	CHIP STORAGE/DRYING FACILITY	1

[NAI-15317010](#)

BUSINESS AFFAIRS AND HUMAN RESOURCES
APRIL 17-18, 2024

ATTACHMENT 9

Schedule 15: KPI Calculation Appendix ~~23~~24

760	TRANSFORMER STORAGE	0.25
761	CHIP FACILITY SCALE HOUSE	0.25
770	INTEGRATED RESEARCH & INNOV CT	1
771	RECLAIM WATER CHLORINATION BLD	1
788	YARD CONTAINERS - SMALL	0.25
789	YARD CONTAINERS - LARGE	0.25
800	INTERMODAL TRANSIT CENTER	1
801	PUBLIC SAFETY & SECURITY	0.25
813	GOLF COURSE PUMPHOUSE	0.5
820	AQUACULTURE RESEARCH INSTITUTE	1
823	PREEC COMMODITY STORAGE BINS	0.25
835	COLLEGE OF EDUCATION BUILDING	1
838	SOIL STEWARDS FARM BARN	0.25
839	MONSON BARN CATTLE STRUCTURE	0.25
840	IDAHO ARENA	1
841	VANDAL GOLF PERFORMANCE CENTER	0.25
847	FACILITIES EQUIPMENT STORAGE	0.25
850	UNIVERSITY HOUSE	1
	WEST FARM BEEF STOCK TANK	0.25
	MONSON BARN STOCK TANK	0.25
	PEA AND LENTAL SERVICE	0.25
CITY OF MOSCOW	CITY OF MOSCOW SEWER TREATMENT DECHLORINATION	1
CITY OF MOSCOW	CITY OF MOSCOW SEWER TREATMENT	1
CITY OF MOSCOW	CITY OF MOSCOW SEWER HEADER	1

[NAI-1531701023v9](#)

Summary report:	
Litera Compare for Word 11.6.0.100 Document comparison done on 3/26/2024 10:49:12 PM	
Style name: JD Color With Moves	
Intelligent Table Comparison: Inactive	
Original DMS: iw://naiweb.firm.jonesday.net/NAI/1511902948/13	
Modified DMS: iw://naiweb.firm.jonesday.net/NAI/1531701023/9	
Changes:	
<u>Add</u>	528
Delete	556
Move From	3
<u>Move To</u>	3
<u>Table Insert</u>	81
Table Delete	33
<u>Table moves to</u>	0
Table moves from	0
Embedded Graphics (Visio, ChemDraw, Images etc.)	0
Embedded Excel	0
Format changes	0
Total Changes:	1204

THIRD AMENDMENT TO PRE-CLOSING AGREEMENT

THIS THIRD AMENDMENT TO PRE-CLOSING AGREEMENT (this “Third Amendment”) is made as of October 1, 2023 and effective as of June 30, 2023, by and between The Regents of the University of Idaho (the “University”) and Sacyr Plenary Utility Partners Idaho LLC, a Delaware limited liability company (the “Concessionaire” and, together with the University, the “Parties”).

A. The University and the Concessionaire have entered into that certain Long-Term Lease and Concession Agreement for the University of Idaho Utility System, dated as of November 2, 2020 (as may be amended, modified, or supplemented, the “Concession Agreement”).

B. The University and the Concessionaire have entered into that certain Pre-Closing Agreement dated December 22, 2020 (the “Original Agreement”), as amended by that certain First Amendment to Pre-Closing Agreement dated June 30, 2021 (the “First Amendment”), as further amended by that certain Second Amendment to Pre-Closing Agreement dated June 30, 2022 (the “Second Amendment” and, together with the Original Agreement and the First Amendment, the “Original Amended Agreement”), pursuant to which, among other things, the University agreed to receive, through the State of Idaho, Department of Administration, Division of Insurance the Substitute Policy (as defined in the Original Agreement) for the Applicable Insured Property (as defined in the Original Agreement) during the University Coverage Period (as defined in the Original Agreement) because the All Risk Property Insurance with respect to the Utility System required to be maintained by the Concessionaire in accordance with Section 13.1(h) of the Concession Agreement was not available to the Concessionaire on a commercially reasonable basis or on commercially reasonable terms.

C. The Parties now wish to amend the Original Amended Agreement to, among other things, authorize the University to request the State of Idaho, Department of Administration, Division of Insurance to purchase and hold a new Substitute Policy, as defined below, which would replace the Substituted Policy under the Original Amended Agreement.

NOW, THEREFORE, the University and the Concessionaire agree as follows:

1. Recitals

The foregoing recitals are incorporated into this Third Amendment as if set forth in full.

2. Definitions

(a) Unless expressly provided otherwise, or the context otherwise requires, (i) capitalized terms used but not defined herein shall have their respective meanings set forth in the Original Amended Agreement and (ii) references to Sections, Articles, and clauses herein shall be references to Sections, Articles and clauses of the Concession Agreement. The term “Agreement” as used in the Original Amended Agreement shall mean and refer to the Original Amended Agreement as amended by this Third Amendment.

(b) “Substitute Policy” shall mean, from and after July 1, 2023, and for purposes of the Original Amended Agreement and this Third Amendment, the All Risk Property Insurance for the Applicable Insured Property required by Section 13(h), acquired by and on such terms and conditions, coverages, limits, and exclusions with respect to Utility Assets as the State of Idaho, Department of Administration, Division of Insurance may determine in its sole discretion.

(c) “Applicable Insured Property” shall mean, from and after July 1, 2023, and for purposes of the Original Amended Agreement and this Third Amendment, the Utility System Assets that are covered by the Substitute Policy; provided that the Substitute Policy may not provide coverage for the entire Utility System and, for the avoidance of doubt, the maintenance, repair, replacement, restoration, and operation of any portion of the Utility System not insured by the Substitute Policy shall remain the responsibility of the Concessionaire, including the Restoration obligations set forth in Section 13.4. Upon the Concessionaire’s written request, the University shall provide the Concessionaire with a copy of the Substitute Policy.

3. Extension of University Coverage Period

(a) The Parties hereby agree that the University Coverage Period shall be extended to be from the Time of Closing until the earlier of (i) June 30, 2024 or (ii) such earlier date when the Required Coverages under Section 13.1(h) become available to the Concessionaire on a commercially reasonable basis or commercially reasonable terms. During the University Coverage Period, the University shall continue to maintain the Substitute Policy that it receives through the State of Idaho, Department of Administration, Division of Insurance in accordance with the Original Agreement (as modified hereby) to the extent of the coverage provided by the State of Idaho. From and after the date hereof, the Parties agree that the Substitute Policy shall include a deductible (after taking into account any self-insured retention for which the Concessionaire is not responsible) not to exceed \$10,000.

(b) Consistent with the First Amendment and the Second Amendment, the University shall not name the Concessionaire, the Operator, Moscow ID Eco District I, LLC, as a Contractor to the Operator, or any Leasehold Mortgagee as additional insureds with respect to the Substitute Policy, and the Parties acknowledge that none of the foregoing had been listed as additional insureds with respect to the Substitute Policy prior to the date hereof. The University and the Concessionaire acknowledge and agree that the Operator, Sub-Operator and any Leasehold Mortgagee of whom the University has received notice shall be named as loss payees of the Substitute Policy for the University Coverage Period up to their respective interests in the Utility System.

(c) On or before the date which is thirty (30) days after the execution of this Third Amendment, the Concessionaire shall pay to the University \$142,653, the estimated annual premium for the Substitute Policy (the “Estimated Premium”). The Parties acknowledge that, as of the time of execution of this Third Amendment, the actual amount of the premium for the Substitute Policy is unknown. Once the State of Idaho, Department of Administration, Division of Insurance notifies the University of the actual annual premium

payable for the Substitute Policy (the “Extension Policy Premium”), the difference between the Extension Policy Premium and the Estimated Premium, if positive, shall be payable by the Concessionaire to the University within thirty (30) days after the date of the University’s demand. If the difference between the Extension Policy Premium and the Estimated Premium is negative, the University shall refund the difference to the Concessionaire within thirty (30) days after the date of the Concessionaire’s demand. The amount of the Extension Policy Premium will be subject to adjustment only to the extent the University Coverage Period terminates before June 30, 2024, in which case the University shall refund a portion of the Extension Policy Premium equal to the Extension Policy Premium multiplied by a fraction, whose numerator is the number of days between the date of termination and the denominator is 365. The Concessionaire shall not include the cost of the Extension Policy Premium as an additional Capped O&M Cost but shall instead require the Sub-Operator to bear the cost without any increase in the fee payable by the Concessionaire to the Operator in accordance with Section 3.3(e).

(d) The University hereby waives the Concessionaire’s requirement to comply with Section 13.1(h) with respect to the Applicable Insured Property or Section 13.3 to the extent related to the Concessionaire Required Coverage for the Applicable Insured Property described in Section 13.1(h) during the extension of the University Coverage Period; provided however, that notwithstanding the foregoing, the Concessionaire shall maintain and evidence equipment breakdown coverage with respect to the entire Utility System, as applicable.

4. Miscellaneous

(a) Conflict. In the event the terms of the Original Amended Agreement conflict with the terms of this Third Amendment, the terms of this Third Amendment shall control and govern.

(b) Original Amended Agreement in Full Force and Effect. Except as expressly modified herein, the Original Amended Agreement remains in full force and effect. For the avoidance of doubt, the Concessionaire retains the obligations in the Concession Agreement, including but not limited to Sections 3.2, 3.22, 13.3(h), 13.4(a).

(c) Severability. Each provision of this Third Amendment shall be valid and enforceable to the fullest extent permitted by applicable Law. The invalidity of any one or more phrases, sentences, clauses or sections contained in this Third Amendment shall not affect the remaining portions of this Third Amendment or any part thereof. If any provision of this Third Amendment or the application thereof to any Person or circumstance is held or deemed to be or determined to be invalid, inoperative or unenforceable in any particular case in any particular jurisdiction or jurisdictions because it conflicts with any other provision or provisions hereof or of any applicable Law, or public policy, or for any other reason, (i) such circumstance shall not have the effect of rendering the provision in question inoperative or unenforceable in any other case or circumstance, or rendering any other provision or provisions herein contained invalid, inoperative or unenforceable to any extent whatsoever and (ii) the Parties shall negotiate in good faith to amend this Third Amendment to implement the provisions set forth herein.

(d) Counterparts; Electronic Execution. This Third Amendment may be executed in any number of counterparts which, taken together, shall constitute one and the same agreement. This Third Amendment shall be effective when it has been executed by each Party and delivered to both Parties. To evidence the fact that it has executed this Third Amendment, a Party may send a copy of its executed counterpart to the other Party by email or other means of electronic transmission. Such Party shall be deemed to have executed and delivered this Third Amendment on the date it sent such email or other means of electronic transmission. In such event, such Party shall forthwith deliver to the other Party an original counterpart of this Third Amendment executed by such Party.

[SIGNATURES ON THE FOLLOWING PAGE]

IN WITNESS WHEREOF, the Parties have caused their duly authorized officers to execute and deliver this Third Amendment as of the day and year first written above.

UNIVERSITY:

THE REGENTS OF THE UNIVERSITY OF
IDAHO

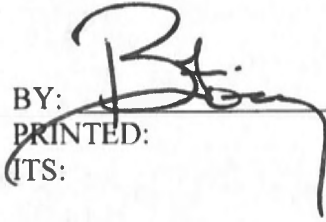
BY: 
PRINTED:
ITS:

[Signature Page to Third Amendment to Pre-Closing Agreement]

CONCESSIONAIRE:

SACYR PLENARY UTILITY PARTNERS IDAHO
LLC

BY: _____
PRINTED:
ITS:

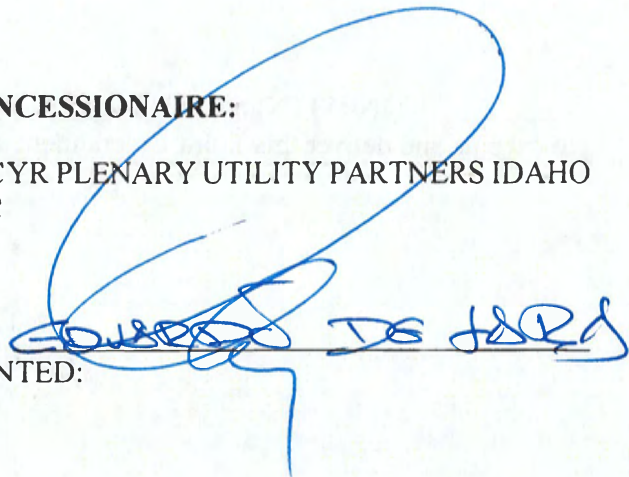

SACYR PLENARY UTILITY PARTNERS IDAHO
LLC

BY: _____
PRINTED: Jerry Mahnger
ITS:



[Signature Page to Third Amendment to Pre-Closing Agreement]

NAI-1537860908v4

BUSINESS AFFAIRS AND HUMAN RESOURCES
APRIL 17-18 2024

UNIVERSITY OF IDAHO

SUBJECT

Updated Six-Year Capital Plan (FY25-30)

APPLICABLE STATUTE, RULE, OR POLICY

Idaho State Board of Education Governing Policies & Procedures, Sections V.K.2.a and b.

BACKGROUND/DISCUSSION

The University of Idaho is providing an updated Six-Year Capital Plan to reflect the addition of one project to the plan.

Huckabay Medical Education Building Expansion

The University of Idaho renovated the former Business Technology Incubator building on campus in 2019 and repurposed it to serve the needs of the Washington, Wyoming, Alaska, Montana, Idaho (WWAMI) Medical Education Program. Upon completion of the renovation effort the facility was renamed the D.A. Huckabay Medical Education Building. As the medical education curriculum and programs have grown in the five years since, and are anticipated to grow further, the facility requires expansion to add space for additional faculty offices, classroom, and support spaces. The site plan of the original structure accounted for an eventual expansion of the facility. The university has engaged in a pre-planning feasibility exercise with the architectural team responsible for the 2019 renovation. Based on the pre-planning work to date, the estimated cost of general construction for this proposed expansion is \$2,492,000. Owner's costs, estimated costs of architectural services, reasonable and rational construction and project contingencies bring the total estimate project costs to \$3,496,900.

IMPACT

This project is key in the success of the University's strategic plan regarding medical education opportunities to serve the State of Idaho. There is no material financial impact from approval of the updated Six-Year Capital Plan. The University will seek approval of the individual construction project described above in compliance with Board policy, at which time the financial impact of the project will be addressed in accordance with applicable policy.

ATTACHMENTS

Attachment 1 – Revised Six-Year Capital Plan

STAFF COMMENTS AND RECOMMENDATIONS

Under Board Policies and Procedures, Section V.K.2.b – If a Major Project is not included in a Plan and an institution or agency under the governance of the Board desires to obtain approval of the Major Project, before seeking approval, it shall

BUSINESS AFFAIRS AND HUMAN RESOURCES
APRIL 17-18 2024

first bring an amended Plan to the Board for Approval at a regularly scheduled meeting of the Board.

Staff recommends approval.

BOARD ACTION

I move to approve the revision to the FY25–30 University of Idaho’s six-year capital plan as submitted in Attachment 1.

Moved by _____ Seconded by _____ Carried Yes _____ No _____

BUSINESS AFFAIRS AND HUMAN RESOURCES
APRIL 17-18, 2024

ATTACHMENT 1

SET C: SIX YEAR CAPITAL IMPROVEMENT PLAN
(Major Capital Projects greater than \$1 mil Total Project Cost)
FY 2025 THROUGH FY 2030
(\$ in 000's)

Institution: University of Idaho

FY2025 FINAL Submittal 1 Jul 23, REVISED 17 Apr 24

Project Title	Est. Cost	Prev. Fund.	FY 2025			FY 2026			FY 2027			FY 2028			FY 2029			FY 2030		
			PBF	Other	Total	PBF	Other	Total	PBF	Other	Total	PBF	Other	Total	PBF	Other	Total	PBF	Other	Total
1 Moscow Campus HVAC Network Controls Revisions and Improvements, CP210043, DPW 21-259	1,336	1,336	In Punch List Status as of 1 Jul 23																	
2 Idaho Center for Plant and Soil Health, Parma CP210009, DPW 21-272	12,150	12,150	In Const Status as of 1 Jul 23																	
3 6th Street Greenhouses Addition, Ph. 1 CP190096	1,430	1,430	In Const Status as of 1 Jul 23																	
4 Idaho Center for Agriculture, Food, and Environment (CAFE) Research Dairy, Rupert, Ph. 1 CP200007, DPW 18-257	25,497	25,497	In Const Status as of 1 Jul 23																	
5 Ag Science HVAC, Phase 1 CP200001, DPW 20-251	6,566	6,566	In Const Status as of 1 Jul 23																	
6 Campus Drive Repairs, Phase 2, CP210048, DPW 21-268	1,512	1,512	In Award Status as of 1 Jul 23																	
7 J.W. Martin Lab Building Systems Improvements CP230000, DPW 23-250	3,000	3,000	In Design Status as of 1 Jul 23																	
8 South Campus Chiller Plant Chiller Replacement CP230017, MIED1/SPUPI FY2022 CapEx 22-15	3,902	3,902	In Design Status as of 1 Jul 23																	
9 Energy Plant Water Treatment Improvements, Ph.1 CP230025, MIED1/SPUPI FY2023 CapEx 23-106	1,400	1,400	In Design Status as of 1 Jul 23																	
10 Energy Plant Wood Fuel Handling System Upgrades CP230026, MIED1/SPUPI FY2023 CapEx 23-107	2,340	2,340	In Design Status as of 1 Jul 23																	
11 ASUI Kibbie Activity Center Electrical Service Replacement CP230047, MIED1/SPUPI FY2023 CapEx 23-317	2,002	2,002	In Design Status as of 1 Jul 23																	
12 Energy Plant Ash Handling System Upgrades UI CP TBD, MIED1/SPUPI FY2023 CapEx 23-102	3,178	3,178	In Planning Status as of 1 Jul 22																	
13 Energy Plant Boiler Controls Modernization UI CP TBD, MIED1/SPUPI FY2023 CapEx 23-109	4,463	4,463	In Planning Status as of 1 Jul 23																	
14 FY2023 Deferred Maintenance Funds, Original UI Allocation of \$41 mil per DPW. After distribution to existing projects, the remaining amount is \$25.343 mil, placed into DPW PN 23-882. Note: Distributions to specific projects TBD.	25,343	25,343	In Planning Status as of 1 Jul 23																	
15 West Nez Perce Drive Reconfiguration and Rebuild CP240004, DPW 24-254	1,107	1,107	In Planning Status as of 1 Jul 23																	
16 Administration Building HVAC, Phase 2 CP240006, DPW 24-256	1,429	1,429	In Planning Status as of 1 Jul 23																	
17 Huckabay Medical Education Building Expansion UI CP TBD, In Pre-planning & Feasibility Status as of 17 April 2024	3,497	0	0	3,497	3,497															
18 Hartung Theater New Elevator, FY2025 ADA Category Request Priority 01 CP230005, DPW 23-255 Note: In Design Status as of 1 Jul 23. Requesting \$476,000 PBF funds (FY2025 ADA Category) to supplement existing funds.	1,480	1,004	476	0	476															
19 Meat Science and Innovation Center, FY2025 Maj Cap Request Priority 01 CP200032 Note: In Design Status as of 1 Jul 23. Requesting \$2 mil PBF funds (FY2025 Major Capital Category) to supplement existing funds. In addition, UI is contributing add'l funds.	14,100	10,350	2,000	1,750	3,750															

BUSINESS AFFAIRS AND HUMAN RESOURCES

APRIL 17-18, 2024

ATTACHMENT 1

SET C: SIX YEAR CAPITAL IMPROVEMENT PLAN
 (Major Capital Projects greater than \$1 mil Total Project Cost)
FY 2025 THROUGH FY 2030
 (\$ in 000's)

Institution: University of Idaho

FY2025 FINAL Submittal 1 Jul 23, REVISED 17 Apr 24

Project Title	Est. Cost	Prev. Fund.	FY 2025			FY 2026			FY 2027			FY 2028			FY 2029			FY 2030		
			PBF	Other	Total	PBF	Other	Total	PBF	Other	Total	PBF	Other	Total	PBF	Other	Total	PBF	Other	Total
20 McCall Field Campus Improvements, Dining Lodge and Kitchen, FY2025 Maj Cap Request Priority 02 Note: In Programming Status as of 1 Jul 23. Requesting \$2 mil PBF funds (FY2025 Major Capital Category) to supplement existing funds.	6,000	4,000	2,000	0	2,000															
21 Idaho Center for Agriculture, Food, and Environment (CAFE) Research Dairy, Rupert, Ph. 2	23,500	0	0	23,500	23,500															
22 Joint ROTC Military Studies Facility FY2025 Maj Cap Request Priority 03	10,000	0	9,000	1,000	10,000															
23 West Campus Neighborhood Improvements FY2025 Maj Cap Request Priority 04	5,000	0	5,000	0	5,000															
24 Art and Architecture Main HVAC Improvements FY2025 A&R Category Request Priority 03	1,375	0	1,375	0	1,375															
25 Idaho Ave Pedestrian Mall Improvements, Pine Street Pedestrian Mall to Line Street Pedestrian Mall FY2025 A&R Category Request Priority 04	1,100	0	1,100	0	1,100															
26 Paradise Creek Pedestrian Bridge at Hello Walk Alignment FY2025 A&R Category Request Priority 05	1,131	0	1,131	0	1,131															
27 Administration Building HVAC, Phase 3 FY2025 A&R Category Request Priority 06	1,375	0				1,375	0	1,375												
28 Admin Building Convert Former NOC to Offices & Renovate Southeast Entry FY2025 A&R Category Request Priority 16	1,250	0				1,250	0	1,250												
29 McCall Field Campus Improvements Teaching and Learning Center #	5,300	0				0	5,300	5,300												
30 Paradise Creek Pedestrian Bridge at Lot 60 Walkway Alignment FY2025 A&R Category Request Priority 21	1,134	0							1,134	0	1,134									
31 McCall Field Campus Improvements Student Lodging #	1,000	0							0	1,000	1,000									
32 Idaho Center for Agriculture, Food, and Environment (CAFE), Food Processing Pilot Facility at CSI, Twin Falls	5,000	0										0	2,500	2,500		2,500	2,500			
33 4th Street Building Renovations and Improvements #	1,000	0																		
34 South Hill Housing Development # Housing and Auxilliary Facilities P3 Priority 1.A	TBD	0																		
35 Graduate Student and Professional Housing # Housing and Auxilliary Facilities P3 Priority 1.B	TBD	0																		
36 Undergraduate Apartment Housing # Housing and Auxilliary Facilities P3 Priority 1.C	TBD	0																		
37 Wallace Residence Center Renovations and Improvements # Housing and Auxilliary Facilities P3 Priority 1.D	TBD	0																		
38 Engineering/STEM Education/Classroom Facility #	40,000	0																		
39 Community Center Facility #	7,500	0																		
Totals:	227,397	112,009	22,082	29,747	51,829	2,625	5,300	7,925	1,134	1,000	2,134	0	2,500	2,500	0	2,500	2,500	0	0	0

BUSINESS AFFAIRS AND HUMAN RESOURCES
APRIL 17-18, 2024

UNIVERSITY OF IDAHO

SUBJECT

Request for design authorization; proposed Huckabay Medical Education Building Expansion, University of Idaho (UI), Moscow, Idaho.

REFERENCE:

- | | |
|---------------|---|
| February 2018 | Idaho State Board of Education (Board) authorized the construction phase for WWAMI Medical Education Building renovation project. |
| December 2021 | Board approved the naming of the WWAMI Medical Education Building as the "D.A. Huckabay M.D. Medical Education Building." |
| April 2024 | University of Idaho requests revision of the FY25-FY30 UI Six-Year Capital Improvement Plan. |

APPLICABLE STATUTE, RULE, OR POLICY

Idaho State Board of Education Governing Policies & Procedure, Section V.K.1, and Sections V.K.3.

BACKGROUND/DISCUSSION

This is a request to authorize the design phase of a project to expand the Huckabay Medical Education Building located on the Moscow Campus of the University of Idaho.

The University of Idaho renovated the former Business Technology Incubator Building on campus in 2019 and repurposed it to serve the needs of the Washington, Wyoming, Alaska, Montana, Idaho (WWAMI) Medical Education Program. Upon completion of the renovation effort the facility was renamed the D.A. Huckabay Medical Education Building. As the medical education curriculum and programs have grown in the five years since, and are anticipated to grow further, the facility requires expansion to add space for additional faculty offices, classroom, and support spaces. The site plan of the original structure accounted for an eventual expansion of the facility. The university has engaged in a pre-planning feasibility exercise with the architectural team responsible for the 2019 renovation. The proposed addition is approximately 5,000 gsf. The site plan of the original structure accounted for an eventual expansion of the facility.

The project is consistent with the strategic goals and objectives of the University of Idaho and is key to the success of the University's strategic planning regarding medical education opportunities to serve the State of Idaho

BUSINESS AFFAIRS AND HUMAN RESOURCES
APRIL 17-18, 2024

In addition, the project is fully consistent with the principles, goals, and objectives of UI's Long Range Campus Development Plan (LRCDP).

IMPACT

Based on the pre-planning and feasibility work to date, the estimated cost of general construction for this proposed expansion is \$2,492,000. Owner's costs estimated costs of architectural services, reasonable and rational construction and project contingencies bring the total estimate project costs to \$3,496,900.

The source of funds for this project effort is WWAMI program funds set aside for this project initiative.

This request is for authorization to proceed with the design phase for the proposed expansion of the Huckabay Medical Education Building. The University seeks authority to expend \$805,540 during the design phase, based upon estimated costs for A/E fees, other planning necessities such as site survey, geotechnical investigation, plan review fees, and design phase contingency allowances.

Overall Project

<u>Funding</u>		<u>Estimate Budget</u>	
State		A/E & Consultant Fees	\$ 167,952
Federal (Grant)		Construction	2,492,000
Other (UI)		Construction Cont.	199,360
WWAMI	\$ 3,496,900	Owner Cost & FFE	536,794
		Project Cont.	<u>100,794</u>
Total	\$ 3,496,900	Total	\$ 3,496,900

ATTACHMENTS

Attachment 1 – Capital Project Tracking Sheet

Page 4

STAFF COMMENTS AND RECOMMENDATIONS

The authorization of this request will allow the University of Idaho to progress with the planning and design phase of the intended expansion of the Huckabay Medical Education Building. The project will increase the capacity of the existing facility by approximately 5,000 gsf which will add space for additional faculty offices, classrooms, and support spaces to accommodate the growth in UI's medical education curricula and programs over the past five (5) years.

UI's request for the Board to authorize project planning and design costs of \$805,540 is based upon estimated costs for architectural and engineering fees, site survey costs, geotechnical investigation, plan review fees, and design phase contingency allowances.

Under Board Policy V.K., if a project is estimated to exceed \$2M, it is defined as a "major project." Under Board Policy V.K.3.a. the institutions are required to obtain

BUSINESS AFFAIRS AND HUMAN RESOURCES
APRIL 17-18, 2024

Board approval for the planning and design process of a major project which is estimated to eventually cost in excess of \$2M. (Present estimated total project costs are estimated to be approximately \$3.5M)

Staff recommend approval.

BOARD ACTION

I move to approve the University of Idaho request to proceed with the design phase for the proposed expansion of the Huckabay Medical Education Building, for a total cost of \$805,540 as described in the materials presented. Approval includes the authority for the Vice President for Finance and Administration to execute all necessary and requisite consulting and vendor contracts to implement the planning and design phase of this project.

Moved by _____ Seconded by _____ Carried Yes _____ No _____

BUSINESS AFFAIRS AND HUMAN RESOURCES
APRIL 17-18, 2024

Office of the Idaho State Board of Education										
Capital Project Tracking Sheet										
As of April, 2024										
History Narrative										
1	Institution/Agency:	University of Idaho			Project:	Capital Project Authorization Request, proposed Huckabay Medical Education Building Expansion, University of Idaho (UI), Moscow, Idaho.				
2	Project Description:	A Capital Project to provide for the design of project to design and construct a proposed expansion of the Huckabay Medical Education Building on the Moscow campus of the University of Idaho.								
3	Project Use:	the proposed expansion of the Huckabay Medical Education Building add space for additional faculty offices, classroom, and support spaces in support of the University's strategic planning regarding medical education opportunities to serve the State of Idaho								
4	Project Size:	Approx. 5,000 gsf								
5										
6		Sources of Funds				Use of Funds*				
7	Project Cost History:				Total Sources	Planning	Use of Funds Const	Other**	Total Uses	
8		PBF	ISBA	Other						
9	Initial Cost of Project, Design Phase Authorization Request. April 2024	\$ -	\$ -	\$ 3,496,900	\$ 3,496,900	\$ 167,952	\$ 2,691,360	\$ 637,588	\$ 3,496,900	
10										
11	History of Revisions:									
12										
13										
14	Total Project Costs	\$ -	\$ -	\$ 3,496,900	\$ 3,496,900	\$ 167,952	\$ 2,691,360	\$ 637,588	\$ 3,496,900	
15	* Figures quoted are for the Total Project Cost. The University intent is that any unused funding is carried forward to a future construction phase at the time such future construction phase may be approved by the Board of Regents.									
16	** Owner's Costs, FFE, & Project Contingency, Any carry forward amounts are to be used in future phases which may be approved by the Board of Regents.									
17										
18										
19	History of Funding:	PBF	ISBA	Institutional Funds (Gifts/Grants)	Student Revenue	Other***	Total Other	Total Funding		
20	Initial Cost of Project, Design Phase Authorization Request. April 2024	\$ -	\$ -	\$ -	\$ -	\$ 3,496,900	\$ 3,496,900	\$ 3,496,900		
21										
22										
23										
24	Total	\$ -	\$ -	\$ -	\$ -	\$ 3,496,900	\$ 3,496,900	\$ 3,496,900		
25	*** UI WWAMI Program									